



DEFINE | PLAN | OPERATE



S-K 1300 Technical Report Summary on the Keno Hill Mine, Yukon, Canada

Prepared by:

Mining Plus Canada Ltd.
999 Canada Pl, Suite 504
Vancouver, B.C., Canada
Canada V6C 3E1

Prepared for:

Hecla Mining Company
6500 N. Mineral Drive, Suite 200
Coeur d 'Alene, Idaho
USA 83815

Report Effective Date – December 31, 2023

Report Issue Date – February 15, 2024

NOTE REGARDING FORWARD-LOOKING INFORMATION

This Technical Report Summary contains “forward-looking statements” within the meaning of Section 27A of the Securities Act of 1933, as amended, and Section 21E of the Securities Exchange Act of 1934, as amended (and the equivalent under Canadian securities laws), which are intended to be covered by the safe harbor created by such sections. Words such as “may”, “will”, “should”, “expects”, “intends”, “projects”, “believes”, “estimates”, “targets”, “anticipates” and similar expressions are used to identify these forward-looking statements. Such forward-looking statements include, without limitation, statements regarding Hecla’s expectation for its mines and any related development or expansions, including estimated cash flows, production, revenue, costs, taxes, capital, rates of return, mine plans, material mined and processed, recoveries and grade, future mineralization, future adjustments and sensitivities and other statements that are not historical facts. Other forward-looking statements in this Report may involve, without limitation, the following:

- Probable Mineral Reserves that have been modified from Indicated Mineral Resource estimates.
- Assumed commodity prices and exchange rates.
- Proposed mine and process production plan.
- Projected mining and process recovery rates.
- Ability to market the two types of concentrate on favorable terms as shown in the LOM plan.
- Sustaining capital costs and proposed operating costs.
- Assumptions as to closure costs and closure requirements.
- Assumptions as to ability to obtain remaining outstanding permits.
- Assumptions about environmental, permitting, and social risks.

The material factors or assumptions used to develop such forward-looking statements or forward-looking information include that Hecla’s plans for development and production will proceed as expected and will not require revision as a result of risks or uncertainties, whether known, unknown, or unanticipated, to which Hecla’s operations are subject.

Estimates or expectations of future events or results are based upon certain assumptions, which may prove to be incorrect, which could cause actual results to differ from forward-looking statements. Such assumptions, include, but are not limited to: (i) there being no significant change to current geotechnical, metallurgical, hydrological and other physical conditions; (ii) permitting, development, operations and expansion of Hecla’s projects being consistent with current expectations and mine plans; (iii) political/regulatory developments in any jurisdiction in which Hecla operates being consistent with its current expectations; (iv) the exchange rate for the USD/CAD being near CAD 1.35 = USD 1.00, the approximate rate as of the date of this Report; (v) certain price assumptions for silver, lead, and zinc; (vi) prices for key supplies being approximately consistent with current levels; (vii) the accuracy of our current mineral reserve and mineral resource estimates; (viii) there being no significant changes to Hecla’s plans for 2024 and beyond with respect to availability of employees, vendors and equipment; (ix) Hecla’s plans for development and production will proceed as expected and will not require revision as a result of risks

or uncertainties, whether known, unknown or unanticipated; (x) sufficient workforce is available and trained to perform assigned tasks; (xi) weather patterns and rain/snowfall within normal seasonal ranges so as not to impact operations; (xii) relations with interested parties, including First Nations and Native Americans, remain productive; (xiii) maintaining availability of water rights; (xiv) factors do not arise that reduce available cash balances; and (xv) there being no material increases in our current requirements to post or maintain reclamation and performance bonds or collateral related thereto.

In addition, material risks that could cause actual results to differ from forward-looking statements include, but are not limited to:

- Unanticipated reclamation expenses.
- Unexpected variations in quantity of mineralization, grade, or recovery rates.
- Exploration risks and results, including that mineral resources are not mineral reserves, they do not have demonstrated economic viability and there is no certainty that they can be upgraded to mineral reserves through continued exploration.
- Geotechnical or hydrogeological considerations during operations being different from what was assumed.
- Failure of mining methods to operate as anticipated.
- Operating risks, including but not limited to failure of plant, equipment, or processes to operate as anticipated.
- Accidents and other risks of the mining industry.
- Silver and other metals price volatility.
- Currency fluctuations.
- Increased production costs and variances in ore grade or recovery rates from those assumed in mining plans.
- Community relations.
- Conflict resolution and outcome of projects or oppositions.
- Litigation, political, regulatory, labor, and environmental risks.
- Inflation causes our costs to rise more than we currently expect.

For a more detailed discussion of such risks and other factors, see Hecla's 2023 Annual Report on Form 10-K. Hecla does not undertake any obligation to release publicly, revisions to any "forward-looking statement," including, without limitation, outlook, to reflect events or circumstances after the date of this presentation, or to reflect the occurrence of unanticipated events, except as may be required under applicable securities laws. Investors should not assume that any lack of update to a previously issued "forward-looking statement" constitutes a reaffirmation of that statement. Continued reliance on "forward-looking statements" is at investors' own risk.

CONTENTS

1.	Executive Summary	22
1.1	Property Description and Ownership	22
1.1.1	Property Description	22
1.1.2	Ownership	24
1.2	History	24
1.3	Geology and Mineralization	25
1.4	Exploration	26
1.5	Mineral Resource Estimates	28
1.6	Mineral Reserve Estimates	29
1.7	Mining Methods.....	30
1.8	Mineral Processing.....	31
1.9	Infrastructure	32
1.10	Environmental Studies, Permitting, and Plans, Negotiations, or Agreements with Local Individuals or Groups.....	33
1.11	Capital, and Operating Cost Estimates.....	34
1.12	Economic Analysis.....	35
1.12.1	Revenue	36
1.12.2	Taxation and Royalties	36
1.12.3	Cash Flow Analysis	36
1.13	Conclusions	38
1.14	Recommendations	38
1.14.1	Geology and Mineral Resources	38
1.14.2	Mining and Mineral Reserves	40
1.14.3	Mineral Processing.....	41
1.14.4	Environmental Studies, Permitting, Social or Community Impacts	41
1.14.5	Economics Analysis	41
2.	Introduction	42
2.1	Terms of Reference and Purpose of the Report	42
2.2	Qualifications of Qualified Persons/Firms and Site Visit	43
2.2.1	Qualified Persons or Firms	43

2.2.2	Site Visit.....	44
2.3	Effective Date.....	45
2.4	Previous Technical Reports.....	45
2.5	Source of Information.....	46
2.6	Units of Measure and Glossary of Terms.....	48
3.	Property Description.....	51
3.1	Property Location, Country, Regional, and Government Setting.....	51
3.2	Mineral Tenure, Agreement, and Royalties.....	51
3.3	Mineral Rights and Permitting.....	55
3.4	Agreements and Royalties.....	56
3.5	Environmental Liabilities and Other Permitting Requirements.....	57
3.6	Mineral and Surface Purchase Agreements.....	58
4.	Accessibility, Climate, Physiography, Local Resources, and Infrastructure.....	59
4.1	Accessibility.....	59
4.2	Topography, Elevation, Vegetation and Climate.....	59
4.3	Physiography.....	60
4.4	Local Infrastructure and Resources.....	60
5.	History.....	61
5.1	History, Drilling, and Past Production of the Bellekeno Deposit.....	62
5.2	History, Drilling, and Past Production of the Lucky Queen Deposit.....	64
5.3	History, Drilling, and Past Production of the Flame and Moth Deposit.....	66
5.4	History, Drilling, and Past Production of the Onek Deposit.....	68
5.5	History, Drilling, and Past Production of the Birmingham Deposit.....	69
6.	Geological Setting, Mineralization, and Deposit.....	72
6.1	Regional Geology.....	72
6.2	Local Geology.....	73
6.3	Property Geology.....	76
6.4	Mineralization.....	77
6.4.1	Bellekeno Deposit Mineralization.....	78
6.4.2	Lucky Queen Mineralization.....	80
6.4.3	Flame and Moth Mineralization.....	80

6.4.4	Onek Mineralization.....	82
6.4.5	Birmingham Mineralization	83
6.5	Deposit Types.....	86
7.	Exploration	87
7.1	Surface Sampling and Mapping	89
7.1.1	Lucky Queen.....	90
7.1.2	Flame and Moth.....	90
7.1.3	Birmingham.....	90
7.2	Underground Sampling	90
7.3	Exploration Drilling – 2006 to 2023	91
7.3.1	Bellekeno Deposit	92
7.3.2	Lucky Queen Deposit	93
7.3.3	Flame and Moth Deposit.....	93
7.3.4	Onek Deposit.....	94
7.3.5	Birmingham Deposit	95
7.3.6	Other Deposits	99
7.4	Geochemistry	105
7.5	Geophysics	105
7.6	Historical Drilling.....	105
7.6.1	Bellekeno Deposit	105
7.6.2	Lucky Queen Deposit	106
7.6.3	Flame and Moth Deposit.....	107
7.6.4	Onek Deposit.....	107
7.6.5	Birmingham Deposit	108
7.7	Drill Hole Logging	108
7.8	QP Opinion.....	109
8.	Sample Preparation, Analyses and Security.....	110
8.1	Sampling and Preparation Procedures	110
8.1.1	Historic Drill Sampling.....	110
8.1.2	Historical Reverse Circulation Sampling	112
8.1.3	Core Drill Sampling (2006 – 2023)	112

8.1.4	Underground Sampling	114
8.2	Laboratories Procedures	115
8.3	Quality Assurance and Quality Control Procedure (QA/QC)	116
8.3.1	Standard Reference Materials	117
8.3.2	Coarse Blank samples.....	120
8.3.3	Coarse Duplicates.....	121
8.3.1	Pulp Duplicates.....	123
8.3.2	Umpire Laboratory Duplicates	124
8.4	Sample Shipment and Security	125
8.5	Specific Gravity Measurements	126
8.6	QP Opinion	126
9.	Data Verification.....	127
9.1	Site Visits	127
9.2	Drilling Database	127
9.3	Verification of Analytical Quality Control	128
9.3.1	Previous reviewers of QA/QC	129
9.4	QP Opinion	130
10.	Mineral Processing and Metallurgical Testing	131
10.1	Initial Characterization and Scoping Studies.....	131
10.1.1	Comminution Data Lucky Queen and Flame and Moth Deposits.....	134
10.2	Metallurgical Laboratory Test-Work Program	135
10.3	Mineralogical Analysis.....	136
10.3.1	Mineralogy Analysis on Bellekeno Samples.....	136
10.3.2	Mineralogy Analysis on Flame and Moth and Lucky Queen Samples	137
10.3.3	Mineralogy Analysis on Birmingham Samples.....	140
10.3.4	Mineralogy Analysis Comparison among Bellekeno, Lucky Queen, Flame and Moth, and Birmingham Samples.....	141
10.4	Metallurgical Results.....	141
10.4.1	Flotation Test Work Overview	141
10.4.2	Bellekeno Samples	142
10.4.3	Lucky Queen Samples	143

10.4.4	Flame and Moth Samples and Blended Composites (Bermingham with Flame and Moth)	143
10.4.5	Bermingham Samples	145
10.4.6	Miscellaneous Test Work	151
10.5	Metallurgical Performance Prediction	151
11.	Mineral Resource Estimates.....	154
11.1	Summary	154
11.2	Key Assumptions, Parameters, and Methods.....	156
11.2.1	Drillhole Database.....	156
11.2.2	Interpretation And Modelling.....	162
11.2.3	Bulk Density Data	172
11.2.4	Compositing	181
11.2.5	Outlier Analysis and Capping	185
11.2.6	Statistical Analysis and Variography	192
11.2.7	Block Model and Grade Estimation	211
11.2.8	Block Model Validation	227
11.3	Mineral Resource Classification	240
11.3.1	Mineral Resource Classification for the Bellekeno Deposit.....	241
11.3.2	Mineral Resource Classification for the Lucky Queen Deposit.....	242
11.3.3	Mineral Resource Classification for the Flame and Moth Deposit	242
11.3.4	Mineral Resource Classification for the Onek Deposit	243
11.3.5	Mineral Resource Classification for the Bermingham Deposit.....	243
11.4	Depletion.....	244
11.5	Basis for Establishing the Prospects of Economic Extraction for Mineral Resources.....	245
11.6	Mineral Resource Statement	246
11.7	Mineral Resource Uncertainty Discussion	246
12.	Mineral Reserve Estimates.....	249
12.1	Mineral Reserve Estimate Methodology	250
12.2	Net Smelter Return and Cut-Off Grade.....	251
12.3	Dilution.....	252
12.4	Recovery.....	254
12.5	Risk Factors that Could Materially Affect the Mineral Reserve Estimate.....	254

13. Mining Methods	255
13.1 Geotechnical and Hydrological Considerations	257
13.1.1 Geotechnical Database	257
13.1.2 Geotechnical Domains	257
13.1.3 Structural Characterization	257
13.1.4 Rock Quality Designation (RQD)	259
13.1.5 NGI Q and GSI Rock Mass Classification Values	260
13.1.6 Ground Support Design.....	261
13.1.7 Pillar Sizing	264
13.2 Hydrological Considerations	264
13.3 Mine Design	264
13.3.1 Mining Method	264
13.3.2 Mine Designs.....	266
13.4 Backfilling	273
13.5 Ventilation.....	273
13.5.1 Mine Air Heating	273
13.5.2 Ventilation Modelling	274
13.6 Mine Services	278
13.6.1 Compressed Air	278
13.6.2 Dewatering.....	278
13.6.3 Power	278
13.6.4 Maintenance Facilities	278
13.7 Mining Fleet	279
13.8 Personnel	281
13.9 Operations	282
13.10 Production Schedule	282
13.11 Recommendations	285
14. Processing and Recovery Methods	286
14.1 Process Unit Operation Description.....	286
14.2 Process Flowsheet and Description	287
14.2.1 Simplified Process Flowsheet.....	287

14.2.2	Run of Mine Ore Crushing, Ore Storage, and Reclaim	288
14.2.3	Primary Grinding Circuit	288
14.2.4	Classification	289
14.2.5	Lead Flotation Circuit	289
14.2.6	Zinc Flotation Circuit	291
14.2.7	Silver and Zinc Concentrates Dewatering and Loadout	293
14.2.8	Mill Changes	296
14.3	Process Design Criteria	297
14.3.1	Mill Design Criteria	298
14.4	Summary of Mass and Water Balances	300
14.4.1	Plant Services	300
14.5	Products and Recoveries	301
14.6	Recommendations	305
15.	Infrastructure	306
15.1	Access Roads	306
15.1.1	Off-Site Facilities	306
15.1.2	Area Haul Road System	306
15.2	Electrical Power Supply and Distribution	308
15.3	Communications	308
15.4	On-Site Infrastructure	308
15.5	Water Management	315
15.5.1	Mine Water	315
15.5.2	Water Treatment	316
15.5.3	Mill Water Supply	319
15.5.4	Receiving Environment	319
15.6	Waste Rock Management	319
15.6.1	Bellekeno Waste Rock Storage Facilities and Disposal Areas	320
15.6.2	Lucky Queen Waste Rock Storage and Disposal Areas	321
15.6.3	Flame and Moth Waste Rock Storage and Disposal Areas	322
15.6.4	Onek Waste Rock Storage Facilities and Disposal Areas	322
15.6.5	Birmingham Waste Rock Storage/Disposal Areas	323

15.7	Tailings	323
15.7.1	Background	323
15.7.2	Overview	324
15.7.3	Closure	327
16.	Market Studies	328
16.1	Market Analysis.....	328
16.1.1	Overview	328
16.1.2	Commodity Price Projections.....	329
16.2	Contracts.....	330
16.2.1	Concentrate Sales	330
16.2.2	Forward Sales.....	331
16.2.3	Other Agreements	331
16.2.4	Other Contracts.....	332
17.	Environmental Studies, Permitting, and Plans, Negotiations, or Agreements with Local Individuals or Groups.....	333
17.1	Site Context.....	333
17.2	Environmental and Socio-Economic Setting.....	334
17.3	Permits and Regulatory Context.....	335
17.4	Community and First Nation Relations Socio-Economic Monitoring	337
17.4.1	Implementation of the Keno Hill City Socio-Economic Mitigation Plan	337
17.4.2	First Nations Relations	337
17.4.3	Community Relations.....	337
17.5	Closure Plan and Security	338
18.	Capital and Operating Costs.....	341
18.1	Capital Costs.....	341
18.1.1	Summary of Capital Cost Estimate.....	341
18.1.2	Mine Capital Expenditure	344
18.2	Operating Costs.....	344
18.2.1	Summary of Operating Cost Estimate.....	344
18.2.2	Operating Costs Basis of Estimate	346
18.2.3	Mine Operating Cost	346
18.2.4	Mill Operating Cost	346

18.2.5	General and Administrative Cost	347
19.	Economic Analysis	348
19.1	Forward-Looking Information and Cautionary Statements.....	348
19.2	Methodology Used.....	348
19.3	Economic Criteria	348
19.3.1	Revenue	349
19.3.2	Capital Costs.....	349
19.3.3	Operating Costs.....	350
19.3.4	Treatment, Refining and Transport.....	350
19.3.5	Taxation and Royalties	351
19.3.6	Closure Cost and Salvage Value	351
19.3.7	Financing	351
19.3.8	Inflation	351
19.4	Economic Analysis.....	352
19.4.1	Pre-Tax Financial Analysis and Results.....	352
19.4.2	Post-Tax Financial Evaluation.....	353
19.5	Sensitivity Analysis	357
19.6	Comments on Economic Analysis	359
20.	Adjacent Properties.....	360
21.	Other Relevant Data and Information	361
22.	Interpretation and Conclusions.....	362
22.1	Property Description and Ownership	362
22.2	Exploration and Mineral Resources	362
22.3	Mining and Mineral Reserves	365
22.4	Metallurgical Testing and Mineral Processing	366
22.5	Infrastructure	366
22.6	Environmental Studies, Permitting, Social or Community Impacts.....	366
22.7	Capital and Operating Costs and Economic Evaluation	367
22.8	Economic Analysis.....	368
23.	Recommendations	369
23.1	Introduction	369

23.2 Geology and Mineral Resources 369

23.3 Mining and Mineral Reserves 370

23.4 Mineral Processing..... 371

23.5 Environmental Studies, Permitting, Social or Community Impacts 372

23.6 Economics Analysis 372

24. References..... 373

25. Reliance on Information Provided by Registrant 377

26. Date and Signature Page 378

Appendix A..... 379

LIST OF TABLES

Table 1-1 – Summary of Mineral Resources – December 31, 2023 – Hecla Yukon – Keno Hill Mine.	29
Table 1-2 – Summary of Mineral Reserves – December 31, 2023, – Hecla Yukon – Keno Hill Mine.....	30
Table 1-3 – LOM Projected Concentrate Grades.	31
Table 1-4 – LOM Projected Concentrate Grades.	32
Table 1-5 – Capital Cost Summary.	34
Table 1-6 – Overall Operating Cost Estimate.	35
Table 1-7 – Financial Summary.	37
Table 2-1 – Report Contributors and Responsibility.....	43
Table 2-2 – List of Abbreviations, Acronyms and Their Associated Definition.	48
Table 3-1 – Relevant Assessment and Regulatory Approvals.....	56
Table 5-1 – District Production through to 1989 (Cathro, 2006).....	62
Table 5-2 — Past Production Records for Bellekeno Property.....	63
Table 5-3 – Historic Resource and Reserve Estimates – Bellekeno (Alexco, 2022a).	64
Table 5-4 – Past Production Records for the Lucky Queen Property (Alexco, 2021b).	64
Table 5-5 – Historic Resource and Reserve Estimates – Lucky Queen (Alexco, 2022a).....	65
Table 5-6 – Past Production Records for the Flame and Moth Property.....	67
Table 5-7 – Historic Resource and Reserve Estimates – Flame and Moth (Alexco, 2022a).....	67
Table 5-8 – Past Production Records for the Onek Property (Alexco, 2021b).....	68
Table 5-9 – Historic Resource and Reserve Estimates – Onek (Alexco, 2022a).....	69
Table 5-10 Past Production Records for the Birmingham Property.	71
Table 5-11 – Historic Resource and Reserve Estimates – Birmingham (Alexco, 2022a).	71
Table 7-1 – Distribution of Drill Holes Completed by Alexco from 2006 to September 2022.....	87
Table 7-2 – Distribution of Drill Holes completed by Hecla from September 2022 to November 2023.	89
Table 7-3 – Significant Intercepts from the 2023 Birmingham Underground Drilling (Hecla, 2023c).....	99
Table 7-4 – Conversion Formula for Imperial to Metric Intercepts.	102
Table 7-5 – Significant Intercepts from the 2022 Silver King Drilling (Hecla, 2023a).	102
Table 7-6 – Significant Intercepts from Coral Wigwam and Hector-Calumet 2022 Drilling (Hecla, 2023a).	103
Table 8-1 – Control Sample Insertion Percentage by Deposit for Keno Hill (2006 – 2023).....	116
Table 8-2 - Control Sample Insertion Percentage by Year for Bellekeno, Lucky Queen, Flame and Moth, Onek, and Birmingham.	116
Table 8-3 - Commercial Standard Reference Material Used for Drilling Programs for the Keno Hill.....	117
Table 8-4 - Standard Reference Material Used by Hecla Developed from the Bellekeno Deposit.	118
Table 8-5 – Compiled Results from Blank Sample Analysis for Bellekeno, Birmingham, Flame and Moth, Lucky Queen, and Onek.	121
Table 8-6 – Compiled Results from Coarse Duplicate Analysis for Bellekeno, Birmingham, Flame and Moth, Lucky Queen, and Onek.	122

Table 8-7 - Compiled Results from Pulp Duplicate Analysis for Bellekeno, Birmingham, Flame and Moth, Lucky Queen and Onek. 123

Table 8-8 – Umpire Lab Duplicates Analysis for Birmingham, Flame and Moth, and Lucky Queen (Hecla,2022c). 125

Table 10-1 – Metallurgical Test Work Programs – 1996 to 2019. 131

Table 10-2 – Flame and Moth Composites for Metallurgical Testing (Alexco, 2021b). 133

Table 10-3 – Birmingham Composites for Metallurgical Testing (Alexco, 2021b). 134

Table 10-4 – Summary Results of BWi Testing (SGS, 2018b). 134

Table 10-5 – Grindability Test Results (Alexco, 2021b). 136

Table 10-6 – Mineral Liberation and Exposure of Flame and Moth and Lucky Queen Samples (Alexco, 2021b). 139

Table 10-7 – Mineral Liberation and Exposure of Birmingham Master Composite (Alexco, 2021b). 141

Table 10-8 – Locked Cycle Testing Summary (2016-2019) (Alexco, 2021b). 142

Table 10-9 – Locked Cycle Flotation Test Results on Bellekeno Samples (Alexco, 2021b). 147

Table 10-10 – Open Cycle Cleaner Flotation Tests on Lucky Queen Test Samples (Alexco, 2021b). 147

Table 10-11 – Open Cycle Cleaner Flotation Test Results on Flame and Moth Samples (Alexco, 2021b). 148

Table 10-12 – Locked Cycle Flotation Test Results on Flame and Moth and Blended Flame and Moth with Birmingham (Alexco, 2021b). 149

Table 10-13 – Open Cycle Cleaner Flotation Test Results on Birmingham Sample (SGS, 2019). 150

Table 10-14 – Locked Cycle Flotation Test Results on Birmingham Samples (Alexco, 2021b). 150

Table 10-15 – Silver and Zinc Concentrate Recoveries and Grades (Hecla, 2024). 153

Table 11-1 – Summary of Mineral Resources – December 31, 2023 – Hecla Yukon – Keno Hill Mine. ... 155

Table 11-2 – Bellekeno Deposit Sample Database (Alexco, 2021b). 156

Table 11-3 – Bellekeno Deposit Samples used for Mineral Resource Estimation (Alexco, 2021b). 156

Table 11-4 – Lucky Queen Deposit Sample Database (Alexco, 2021b). 157

Table 11-5 – Onek Deposit Sample Database Average Assay Values Inside Veins (Alexco, 2021b). 161

Table 11-6 – Bellekeno Bulk Density Measurements (Alexco, 2021b). 173

Table 11-7 – Lucky Queen Bulk Density Measurements (Alexco, 2021b). 174

Table 11-8 – Flame and Moth Bulk Density Data within Mineralized Domains (Alexco, 2021b). 175

Table 11-9 – Onek Bulk Density Measurements (Alexco, 2021b). 177

Table 11-10 – Birmingham Bulk Density Measurements (Hecla, 2023f). 180

Table 11-11 – Composite Capping Levels for the Bellekeno Deposit (Alexco, 2021b). 186

Table 11-12 – Composite Capping Levels for Lucky Queen (Alexco, 2021b). 186

Table 11-13 - Outlier Restriction in the Flame and Moth Deposit for Ag (Hecla, 2023e). 187

Table 11-14 – Sample Capping Levels for Onek (Alexco, 2021b). 188

Table 11-15 – Sample Capping Levels for Birmingham Arctic Zone (Hecla, 2023f). 188

Table 11-16 – Sample Capping Levels for Birmingham Bear Zone (Hecla, 2023f). 189

Table 11-17 – Sample Capping Levels for Birmingham North-East Zone (Hecla, 2023f). 190

Table 11-18 – Sample Capping Levels for Birmingham Etta Zone (Hecla, 2023f). 191

Table 11-19 – Summary Statistics for Bellekeno Compositated and Weighted Data (Alexco, 2021b). 193

Table 11-20 – Summary of Variography for Bellekeno (Alexco, 2021b)..... 193

Table 11-21 – Composite Data Summary Statistics for the Lucky Queen Deposit (Alexco, 2021b)..... 201

Table 11-22 – Modelled Semi-Variogram for Silver (Alexco, 2021b)..... 202

Table 11-23 – Flame and Moth Composite Summary Statistics (Hecla, 2023e)..... 203

Table 11-24 – Composite Data Summary Statistics for Onek (Alexco, 2021b)..... 204

Table 11-25 – Modelled Correlograms for Onek Veins (Alexco, 2021b). 208

Table 11-26 – Birmingham Composite Summary Statistics for the Arctic Zone (Hecla, 2023f). 209

Table 11-27 – Birmingham Composite Summary Statistics for the Bear Zone (Hecla, 2023f). 209

Table 11-28 – Birmingham Composite Summary Statistics for the Etta Zone (Hecla, 2023f). 210

Table 11-29 – Birmingham Composite Summary Statistics for the North East Zone (Hecla, 2023f)..... 210

Table 11-30 – Block Model Location and Setup, MinePlan Convention (Alexco, 2021b)..... 211

Table 11-31 – Search Ellipse Parameters for the Bellekeno Deposit (Alexco, 2021b)..... 212

Table 11-32 – Block model Location and Setup for the Lucky Queen Deposit (Alexco, 2021b)..... 212

Table 11-33 – Search Ellipse Parameters for the Lucky Queen Deposit (Alexco, 2021b)..... 213

Table 11-34 – Block Model location and Setup for the Flame and Moth Deposit (Hecla, 2023e). 213

Table 11-35 – Search Ellipse Parameters for the Lightning Zone in the Flame and Moth Deposit (Hecla, 2023e). 214

Table 11-36 – Search Parameters for the Christal Zone in the Flame and Moth Deposit (Hecla, 2023e). 215

Table 11-37 – Onek Block model Location and Setup (Alexco, 2021b). 216

Table 11-38 – Search Ellipse Parameters for Onek Vein 1 (Alexco, 2021b)..... 217

Table 11-39 – Search Ellipse Parameters for Onek Vein 1F (Alexco, 2021b)..... 217

Table 11-40 – Search Ellipse Parameters for Onek Vein 2 (Alexco, 2021b)..... 218

Table 11-41 – Birmingham Block Model Location and Setup (Hecla, 2023f). 218

Table 11-42 – Search Ellipse Parameters for the Birmingham Arctic Zone (Hecla, 2023f)..... 219

Table 11-43 – Search Ellipse Parameters for the Birmingham Bear Zone (Hecla, 2023f). 220

Table 11-44 – Search Ellipse Parameters for the Birmingham North East Zone (Hecla, 2023f)..... 224

Table 11-45 – Search Ellipse Parameters for the Birmingham Etta Zone (Hecla, 2023f). 225

Table 11-46 - Outlier Restriction Method Applied at Birmingham North East Zone (Hecla, 2023f). 226

Table 11-47 – Comparison Statistics for Ordinary Kriging Estimate versus Inverse Distance Squared Estimate (Alexco, 2021b). 227

Table 11-48 – Comparison Statistics for Ordinary Kriging Estimate versus Nearest Neighbor Estimate (Alexco, 2021b). 227

Table 11-49 – Comparison Statistics for Ordinary Kriging Estimate versus De-clustered Nearest Neighbor Estimate (Alexco, 2021b). 228

Table 11-50 – Lucky Queen Nearest Neighbor Block Model Validation (Alexco, 2021b)..... 229

Table 11-51 – Flame and Moth Deposit Nearest Neighbor Block Model Validation (Hecla, 2023e). 230

Table 11-52 – Birmingham Nearest Neighbor Block Model Validation for the Arctic Zone (Hecla, 2023f). 235

Table 11-53 – Birmingham Nearest Neighbor Block Model Validation for the Bear Zone (Hecla, 2023f). 235

Table 11-54 – Birmingham Nearest Neighbor Block Model Validation for the Etta Zone (Hecla, 2023f).	237
Table 11-55 – Assumptions Considered for Preparing the 2023 Mineral Resource Estimates at Keno Hill.	245
Table 12-1 – Summary of Mineral Reserves – December 31, 2023 – Hecla Yukon – Keno Hill Mine.....	249
Table 12-2 – Metal Prices Used in NSR Calculation.	251
Table 12-3 – Representative NSR Parameters.	251
Table 12-4 – Keno Hill Mine Cut-off Values by Cost Area.....	252
Table 13-1 – Average Trend of Major Faults in the Birmingham Deposit.	258
Table 13-2 – Summary of RQD Values for Flame and Moth and Birmingham Deposits by Geotechnical Domain.....	260
Table 13-3 – Summary of NGI Q values for Flame and Moth and Birmingham Deposits by Geotechnical Domain.....	261
Table 13-4 – General Summary of Rock Mass Classification for Keno Hill.	261
Table 13-5 – Development Excavation Dimensions by Type and Stand-up Time.....	262
Table 13-6 – Flame and Moth and Birmingham Ground Support Standard (Hecla, 2023d and Hecla, 2022c)	262
Table 13-7 – Lucky Queen Production Quantities.	268
Table 13-8 – Flame and Moth Production Quantities.	270
Table 13-9 – Birmingham Production Quantities.	272
Table 13-10 – Underground Equipment Fleet.	280
Table 13-11 – Surface Equipment Fleet.....	281
Table 13-12 – Estimated Annual Personnel Requirements for Keno Hill Mine.	282
Table 13-13 – LOM Plant Feed Summary.....	283
Table 14-1 – Summary of Reagents.	295
Table 14-3 – Modified Mill Design Criteria (Hecla, 2024).	298
Table 14-4 – Mill Design Criteria.....	299
Table 14-5 – Concentrate Production (Hecla, 2024).....	299
Table 14-6 – LOM Projected Concentrate Grades (Hecla, 2024).....	302
Table 14-7 – LOM Projected Concentrate Production (Hecla, 2024).	303
Table 14-8 – LOM Projected Concentrate Production - Metal Quantities Hecla, 2024).	304
Table 15-1 – Waste Rock Storage by Deposit.	320
Table 16-1 – Mineral Resource Metal Prices – 2023.	329
Table 16-2 – Mineral Reserve Metal Prices – 2023.	329
Table 16-3 – Hecla Historical Average Realized Metal Prices – Keno Hill Mine.....	330
Table 16-4 – Long Term Silver-Lead Concentrate Sales Terms.....	331
Table 16-5 – Long Term Zinc Concentrate Sales Terms.....	331
Table 17-1 – Keno Hill Mine Setting Summary.	335
Table 17-2 – Relevant Approvals, Permits, and Licenses.....	336
Table 18-1 – Summary of Major Capital Cost Categories Across Keno Hill Mine.	343
Table 18-2 – Life of Mine Direct Operating Cost Summary.	345

Table 18-3 – Life of Mine Unit Operating Cost.	345
Table 18-4 – General and Administrative Costs.....	347
Table 19-1 – Economic Criteria Used to Determine Operations Value.	349
Table 19-2 – Summary of LOM Operating Costs.....	350
Table 19-3 – Treatment, Refining, and Transport Cost Statistics (Unit Costs Averaged over LOM).	350
Table 19-4 – LOM Production Summary.....	352
Table 19-5 – Summary of Pre-Tax Financial Results	353
Table 19-6 Cumulative Cash Flow After-Tax (\$ '000).....	354
Table 19-7 – After-Tax Discounted Cash Flow Model.....	355
Table 19-8 – After-Tax NPV Sensitivity Analysis Result Table.....	358

LIST OF FIGURES

Figure 1-1 – Keno Hill Mining Operations Overview.....	23
Figure 3-1 Keno Hill Mining Operations Location Map.....	52
Figure 3-2 Keno Hill Mining Operations Overview.....	53
Figure 3-3 – AKHM/ERDC Quartz Mining Claim and Lease Holdings in the Keno Hill Excluding the Elsa Tailings Property.	54
Figure 6-1 – Regional Geology (Yukon Geological Society, 2022).....	73
Figure 6-2 – Local Geology Simplified Stratigraphic Column of the Keno Hill.	74
Figure 6-3 – Local Geology Cross-section of the Keno Hill (Yukon Geological Society, 2020).....	75
Figure 6-4 – Keno Hill Simplified Stratigraphy Legend (Yukon Geological Survey, 2020).....	75
Figure 6-5 – Geology Map of the Keno Hill (RPA, 2017).	77
Figure 6-6 – Schematic Long Section of the 48 Vein Bellekeno Mine Showing Workings (SRK, 2013).	79
Figure 6-7 – 48 Vein Structures and Mineralogy, Bellekeno Deposit (SRK, 2013).....	79
Figure 6-8 – Vein-Fault Intercept in Drill Hole K-07-0114, Lucky Queen (SRK, 2013).....	80
Figure 6-9 – Vein-Fault Intercept in Drill Hole K-12-0432, Flame and Moth (SRK, 2013).....	81
Figure 6-10 – Vein-Fault Intercept in Drill Hole K-10-0306, Onek (SRK, 2014).....	82
Figure 6-11 – Vein-Fault Intercept in Drill Hole K-15-0580 in the Birmingham Deposit (Mining Plus, 2019).	85
Figure 7-1 – Long Section Showing the Location of 2020 Birmingham Northeast Deep Drilling (Alexco, 2021a).	97
Figure 7-2 – Location Plan Showing Birmingham Deep Northeast Drill Holes (Alexco, 2021d).	98
Figure 7-3 – Plan Showing the Location of 2022 Exploration Drilling (Hecla, 2023a).....	101
Figure 7-4 – Plan View of the Birmingham Area (Hecla, 2023b).	104
Figure 7-5 – Bellekeno Mine Long Section Looking Northwest, 1986 – 1996 UKHM Core Drill Holes (SRK, 2013).	106
Figure 8-1 – Combined Control Chart for Standard PB 137 Showing Results for Silver at Keno Hill Deposits.	119
Figure 8-2 - Combined Control Chart for Standard PB 145 Showing Results for Silver at Keno Hill Deposits.	119
Figure 8-3 - Combined Control Chart for Standard PB 145 Showing Results for silver at Keno Hill Deposits.	120
Figure 8-4 – Compiled Blank Control Samples of Silver for Bellekeno, Birmingham, Flame and Moth, Lucky Queen, and Onek.	121
Figure 8-5 – Compiled Coarse Duplicate Control Samples of Silver for Bellekeno, Birmingham, Flame and Moth, Lucky Queen, and Onek.	122
Figure 8-6 - Compiled Pulp Duplicate Control Samples of Silver for Bellekeno, Birmingham, Flame and Moth, Lucky Queen and Onek.	124
Figure 10-1 – Source Metallurgical Samples from Flame and Moth (Alexco, 2021b).	132
Figure 10-2 – Source of Metallurgical Samples from Birmingham (Alexco, 2021b).....	133

Figure 10-3 – Alexco BWI Results against SGS Database (SGS, 2018b). 135

Figure 10-4 – Mineral Abundance of Flame and Moth and Lucky Queen Samples (SGS, 2019). 138

Figure 10-5 – Modal Mineral Abundance of Bermingham Master Composite (SGS, 2018a). 140

Figure 10-6 – Locked Cycle Flotation Tests Flowsheet on Flame and Moth and Blended Samples (SGS, 2018b). 144

Figure 10-7 – Open Cycle Cleaner Flotation Test Results on Bermingham Master Composite Samples (SGS, 2018a). 145

Figure 10-8 – Locked Cycle Flotation Tests Flowsheet on Bermingham Master Composite Samples (SGS, 2018a). 146

Figure 10-9 – Metal Recoveries at Head Grades for Recovery Projection (Alexco, 2019a)..... 152

Figure 11-1 – Oblique View of Flame and Moth Lightning Zone Wireframe (Pink), Mine As-built (Blue), Drillhole Traces (Grey), and NR Samples (Black) (Hecla, 2023e). 159

Figure 11-2 – Oblique View of Flame and Moth Lightning Zone Wireframe (Pink), Mine As-built (Blue), Drillhole Traces (Grey), and NR Samples (Black) (Hecla, 2023e). 160

Figure 11-3 – Assay and Composite for Drillhole K-21-0787 in the Arctic Zone. 162

Figure 11-4 – Bellekeno Deposit Long Section, Wireframes, Looking North-Northwest (Alexco, 2021b). 163

Figure 11-5 – Bellekeno Deposit Long Section, Wireframes, looking South-Southeast (Alexco, 2021b). 163

Figure 11-6 – Section of Lucky Queen Wireframes Looking Northwest (SRK, 2011a)..... 164

Figure 11-7 – Vein Wireframes and Location of Surface Drilling at Flame and Moth used in Resource Estimation, Section Looking North-Northwest. 165

Figure 11-8 – Long Section of Onek Wireframes Looking South (SRK, 2014). 167

Figure 11-9 – Long Section of Onek Wireframes Looking North (SRK, 2014). 168

Figure 11-10 – Bermingham Geological Model (Plan View). 170

Figure 11-11 – Bermingham Geological Model (3D Oblique View Looking North-East). 171

Figure 11-12 – Cross-cutting Faults (Plan View). 172

Figure 11-13 – Bulk Density vs. All Metal (%) for Bellekeno (Alexco, 2021b)..... 173

Figure 11-14 – Scatter Plot of Lead Assay Results and Bulk Density Measurements for Lucky Queen (SRK, 2011a). 174

Figure 11-15 – Pulp Versus Core SG Values (RPA, 2017). 176

Figure 11-16 – Correlation Between Bulk Density and Metal Content for Onek Veins (RPA, 2017). 178

Figure 11-17 – Comparison of Core and Pulp Density Measurements for Onek (RPA, 2017). 179

Figure 11-18 – Histogram of Sample Lengths for the Mineralized Zones for Bellekeno Deposit (Alexco, 2021b). 182

Figure 11-19 – Flame and Moth Compositing Summary – Length. 183

Figure 11-20 – Histogram of Sample Lengths within Onek Veins (RPA, 2017). 184

Figure 11-21 – Histogram of Sample Lengths for the Mineralized Zones for Bermingham Deposit. 185

Figure 11-22 – Quantile-Quantile Plot of Silver Values in Drillhole vs. Chip Samples Coded to Bellekeno Veins (SRK, 2021). 192

Figure 11-23 – Normal Score Variograms for Capped Silver, Southwest Zone (Alexco, 2021b). 195

Figure 11-24 – Normal Score Variograms for Capped Lead, Southwest Zone (Alexco, 2021b). 196

Figure 11-25 – Normal Score Variograms for Capped Zinc, Southwest Zone (Alexco, 2021b)..... 197

Figure 11-26 – Normal Score Variograms for Capped Silver, 99 Zone (Alexco, 2021b). 198

Figure 11-27 – Normal Score Variograms for Capped Lead, 99 Zone (Alexco, 2021b)..... 199

Figure 11-28 – Normal Score Variograms for Capped Zinc, 99 Zone (Alexco, 2021b)..... 200

Figure 11-29 – Q-Q Plot of Chip and Drill Hole Silver Assay Sample Data (SRK, 2011a)..... 201

Figure 11-30 – Modelled Directional and Downhole Correlograms for Vein 1 and Vein 1 FW (RPA, 2017).
..... 206

Figure 11-31 – Modelled Directional and Downhole Correlograms for Vein 1 and Vein 1 FW (RPA, 2017).
..... 207

Figure 11-32 – Modelled Omnidirectional Correlograms for Vein 2 (RPA, 2017). 208

Figure 11-33 – Swath Plots Comparison of ID2 and NN Estimation (SRK, 2011a)..... 229

Figure 11-34 – Swath Plot Global Ag Comparison for Flame and Moth of ID2 (Red) and NN Estimation
(Blue) in X Direction. 231

Figure 11-35 – Swath Plot Global Ag Comparison for Flame and Moth of ID2 (Red) and NN Estimation
(Blue) in Y Direction. 232

Figure 11-36 – Swath Plot Global Ag Comparison for Flame and Moth of ID2 (Red) and NN Estimation
(Blue) in Z Direction. 233

Figure 11-37 – Comparison of OK and ID2 Estimation for Onek (RPA, 2017)..... 234

Figure 11-38 – Swath Plot Global Ag Comparison for Bermingham of ID2 (Red) and NN Estimation (Blue)
in X Direction..... 238

Figure 11-39 – Swath Plot Global Ag Comparison for Bermingham of ID2 (Red) and NN Estimation (Blue)
in Y Direction..... 239

Figure 11-40 – Swath Plot Global Ag Comparison for Bermingham of ID2 (Red) and NN Estimation (Blue)
in Z Direction..... 240

Figure 11-41 – Bellekeno Mine Long Section, Underground Working Wireframes, Looking North-
Northwest. 244

Figure 13-1 – Keno Hill Mine Location. 256

Figure 13-2 – Plan View of Flame and Moth Showing Fault Offset of Christal Relative to Lightning Mining
Area..... 258

Figure 13-3 – Longitudinal Section View (Looking South-East) of Bermingham. 259

Figure 13-4 – Mechanized Cut and Fill Mining Method Layout..... 266

Figure 13-5 – Lucky Queen Isometric View (Looking South). 267

Figure 13-6 – Flame and Moth (Looking North-West)..... 269

Figure 13-7 – Bermingham Isometric View (Looking Southeast)..... 271

Figure 13-8 – Monthly Average Temperature for Mayo, Yukon Territory (Alexco, 2021b). 274

Figure 13-9 – Lucky Queen Primary Airflow Schematic (Alexco, 2021b)..... 275

Figure 13-10 – Flame and Moth Primary Airflow Schematic. 276

Figure 13-11 – Bermingham Primary Airflow Schematic..... 277

Figure 13-12 Ore and Waste Tonnes – Combined Mines. 283

Figure 13-13 – Ore Tonnes vs. Silver Grade..... 284

Figure 13-14 – Ore Tonnes vs. Base Metal Grade..... 284

Figure 14-1 – Simplified Process Flow Diagram of the Mill Complex (Alexco, 2021b). 288

Figure 15-1 – Keno Hill Area Haul Road System. 307

Figure 15-2 – Bellekeno Site Layout..... 310

Figure 15-3 – Lucky Queen Site Layout..... 311

Figure 15-4 – Flame and Moth Site Layout. 312

Figure 15-5 – Onek Site Layout. 313

Figure 15-6 – Birmingham Site Layout..... 314

Figure 15-7 – Overall DSTF Plan. 325

Figure 19-1 – After-Tax 5% NPV Sensitivity (-/+20% Project Variables). 359

1. EXECUTIVE SUMMARY

Mining Plus Canada Ltd. (Mining Plus) was retained by Hecla Mining Company (Hecla) to prepare an independent Technical Report Summary (sometimes referred to herein as TRS or Report) on the Keno Hill Mine (sometimes referred to herein as Keno Hill or KHM). The purpose of this TRS is to support the disclosure of the Keno Hill Mineral Resource and Mineral Reserve estimates as of the Effective Date, December 31, 2023. This TRS conforms to the United States Securities and Exchange Commission's (SEC) Modernized Property Disclosure Requirements for Mining Registrants as described in Subpart 229.1300 of Regulation S-K, Disclosure by Registrants Engaged in Mining Operations (S-K 1300) and Item 601 (b)(96) Technical Report Summary.

The reported Mineral Resources and Mineral Reserves are based on data collected up to the Effective Date, including operational data collected from the Keno Hill Mine. The cost and economic estimates are current as of the Effective Date December 31, 2023. The database's cut-off date for drillholes included in this report is October 30, 2023.

The conclusion, recommendations, and forward-looking statements made by Qualified Persons (QPs) are based on reasonable assumptions and results interpretations. Forward-looking statements cannot be relied upon to guarantee Keno Hill Mine's performance or outcomes and naturally include inherent risks and risks relating to the industry, Hecla and KHM. Refer to the note regarding forward-looking information at the front of this Report.

Hecla is a public company, established in 1891 with its headquarters in Coeur d'Alene, Idaho, USA. Hecla owns a 100% interest in the mineral rights for KHM through its subsidiaries following its successful acquisition of Alexco Resources Corp. (Alexco) in September 2022.

Keno Hill contemplates the conventional mining and milling of silver-lead-zinc ore from three deposits and there is an existing conventional flotation plant that processes high-grade silver-lead-zinc ore. Over the eleven-year mine life contemplated in this report, the mines are expected to produce 1.88 million (M) tonnes (t) of mill feed (the Probable Mineral Reserves) at an average of 912 grams per tonne (g/t) silver (Ag), 2.81% lead (Pb), 2.53% zinc (Zn) and 0.22 g/t gold (Au). The mill will produce two concentrates: a high-grade silver-lead concentrate (aka silver concentrate) and a zinc-silver concentrate (aka zinc concentrate). The total Ag production is expected to be approximately 52.9 M ounces (oz) over the mine life.

1.1 PROPERTY DESCRIPTION AND OWNERSHIP

1.1.1 PROPERTY DESCRIPTION

Keno Hill is located within the Keno Hill Silver District in Canada's Yukon Territory. The property is situated 350 kilometers (km) north of Whitehorse and lies within the traditional territory of the First Nation of Na-

Cho Nyäk Dun. Access to the property is via the Alaska Highway from Whitehorse to Stewart Crossing (354 km), then from Stuart Crossing to Mayo via the Silver Trail Highway (53 km), and an all-weather gravel road northeast from Mayo to Elsa (45 km); a total distance of 452 km.

Hecla has exploration, maintenance, and camp facilities near the location of the historic mining town of Elsa, which is located just off the Silver Trail Highway, and administration, mill, and mine facilities at the mill complex located near Keno City, as shown in Figure 1-1. Keno Hill is well connected by a network of public and private gravel roads including the Silver Trail Highway and the Bellekeno haul road, which was built to bypass the mining traffic around the village of Keno City. Keno Hill is supplied with electrical power by Yukon Energy Corporation (YEC) from a hydroelectric plant near Mayo and has a connection to the Yukon-wide electrical grid. The area is covered by National Topographic System (NTS) map sheets 105M/13 and 105M/14.

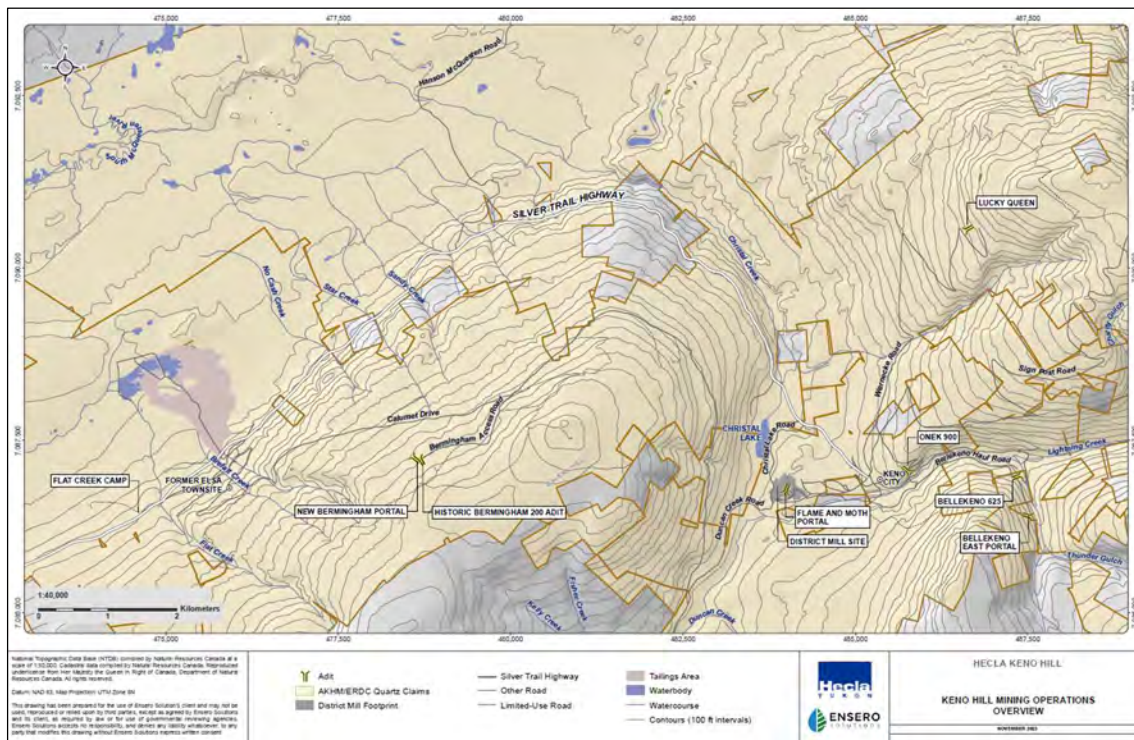

Figure 1-1 – Keno Hill Mining Operations Overview.

Central Yukon is characterized by a subarctic continental climate with cold winters and warm summers. Exploration and mining work can be carried out year-round. The average annual precipitation ranges from 300 millimeters (mm) in the valleys to 600 mm on mountaintops. Half of this amount falls as snow, which starts to accumulate in October and remains into May or June.

Keno Hill’s property area is characterized by rolling hills and mountains with a relief of up to 1,600 meters (m). The highest elevation is Keno Hill at 1,975 m. Slopes are gentle except for the north slopes of Keno Hill and Sourdough Hill. The mining properties at the KHM are located between 900 m and 1,300 m elevation.

1.1.2 OWNERSHIP

Hecla owns a 100% interest in the mineral rights for Keno Hill through its subsidiaries following its successful acquisition of Alexco in September 2022. Elsa Reclamation & Development Company Ltd. (ERDC), a wholly owned subsidiary of Hecla, continues to advance the development and eventual implementation of the District Wide Closure Plan (Existing State of Mine Reclamation Plan) which addresses the historic environmental liabilities of the district from past mining activities pre-dating Alexco’s and Hecla’s acquisition of KHM. The potential liabilities associated with the historic operations in Keno Hill are indemnified by the Government of Canada under the terms and conditions of the Amended and Restated Subsidiary Agreement dated July 18, 2013, executed by ERDC, Alexco and Her Majesty the Queen in right of Canada (ARSA), subject to the requirement for ERDC to develop, permit, and implement the site Reclamation Plan, or if Hecla and the Government agree to transfer portions of the historic area to active mining operations within KHM, in which case such indemnification ceases to the extent of such transferred area.

Keno Hill quartz mining claims and quartz mining leases are held by one of two wholly owned subsidiaries of Alexco (which does business as Hecla Yukon): ERDC or Alexco Keno Hill Mining Company Ltd. (AKHM), except for holding a 50% share with third party individuals in three leases (Rico, Kiddo, and Argentum). The total Keno Hill property quartz mineral holdings as of December 31, 2023, excluding the mineral claims that are the subject of the separate technical report titled Mineral Resource Estimation Elsa Tailings Project Yukon, Canada, by SRK dated June 16, 2010, covers an area of 238.12 km² and comprises 717 quartz mining leases, 867 quartz mining claims, and two Crown Grants.

1.2 HISTORY

The Keno Hill mining camp area has a rich history of exploration and mining dating back to the beginning of the 1900s. In the ensuing 100 years of mining, activity peaked and decreased with changes in silver prices, world events, and operating companies in the Yukon. Notable periods of interest in the historic evolution of the Keno Hill mining camp included:

- After WWI, success at the Keno mine led to a staking rush, resulting in the discovery of a number of rich deposits. In the early 1920s, the Treadwell Yukon Company Limited (TYC) acquired a number of claims and started mining.

- After WWII, there was a sharp decline in activity in the Keno Hill camp until a new company, Keno Hill Mining Company Ltd., later United Keno Hill Mines Ltd. (UKHM), purchased all TYC properties, started production and sparked increased exploration activity.
- Peak mining activity occurred in the 1950s through to the 1970s, with new discoveries across the district adding to mineral inventory.
- UKHM restarted the TYC mill in April 1947 processing ore primarily from Hector Calumet mine and Elsa mine. Production from the Hector Calumet mine increased in the 1950s and it was the primary silver producer in the region. Overall, Hector Calumet produced 96 million ounces of silver over its mine life.
- Open pit mining began in the late 1970s, mainly to recover selected crown pillars; from 1982 to 1985 Sadie-Ladue and Shamrock were mined on a small-scale basis, and from 1989 to 1990 Shamrock, Silver King, Hector-Calumet, Lucky Queen, Bermingham, and Keno were mined.
- UKHM stopped production from the Keno Hill Silver District permanently in early 1989.
- Between 1990 and 1998 Dominion Mineral Resources and Sterling Frontier Properties Company of Canada Limited (Dominion) carried out both reclamation work across the district as well as exploration at the Bellekeno, Husky Southwest, and Silver King mines in order to reopen the camp.
- In the late 1990s, Dominion abandoned its UKHM right driving UKHM into bankruptcy.
- In 2001, the site was declared abandoned by the Government Operations Centre, and the federal government inherited the assets.
- In June 2005, Alexco was selected as the preferred purchaser of the assets of UKHM by PwC, the court-appointed interim receiver and receiver-manager of the Project holdings. In February 2006, the Supreme Court of the Yukon approved Alexco's purchase of UKHM's assets through Alexco's wholly owned subsidiary ERDC.
- Between 2010 and 2013, Alexco operating at approximately 200 tpd produced 5.64 million ounces of silver before suspending mining operations.
- In Q4 of 2020, Alexco returned to operation and produced approximately 0.57 million ounces of silver between 2020 and 2022.
- On September 7, 2022, Hecla completed the acquisition of Alexco.

1.3 GEOLOGY AND MINERALIZATION

The Keno Hill Mine is located within the northwestern part of the Selwyn Basin in central Yukon. The area is underlain by Upper Proterozoic to Mississippian metasedimentary rocks originally deposited in a marine shelf environment along the northern Cordilleran continental margin. The Robert Service Thrust Sheet lying immediately to the south of Keno Hill is composed of Late Proterozoic to Cambrian dominantly coarse-grained quartz-rich turbidite sequence. The Tombstone Thrust Sheet of Devonian phyllite, felsic meta-tuffs, and metaclastic rocks is overlain by the Mississippian Keno Hill Quartzite Formation. The stratigraphy is locally thickened due to folding while the basal portion of the Keno Hill Quartzite forms the dominant host to the silver-lead-zinc mineralization.

Phases of intrusive rocks identified include gabbro and diorite sills, voluminous felsic Tombstone granite intrusions that are regionally related to gold mineralization, and peraluminous megacrystic potassium feldspar granitoids of the Upper Cretaceous McQuesten suite.

The region hosts other mineral occurrences including tungsten, copper, gold, lead, zinc, antimony, and barite.

The Keno Hill local geology is dominated by the Mississippian Keno Hill Quartzite Formation comprising the Basal Quartzite Member conformably overlying Sourdough Hill Member. The sequence is overthrust from the south by the Upper Proterozoic Hyland Yusezyu Formation and is conformably underlain in the north by the Devonian Earn Group.

In 2007, a project was initiated by Alexco to digitally capture the historic UKHM data which included extensive mining plans and geology maps describing up to 70 years of mining. Remapping of the surface geology in the Keno Hill area supported the subdivision of the Keno Hill Quartzite Formation into the Basal Quartzite Member and the Sourdough Hill Member, which reflected the importance of competent Basal Quartzite in the vein formation events.

The Basal Quartzite Member is the dominant host to silver mineralization comprising quartzite and graphitic schists that can reach a thickness of up to 1,100 m thick attributed to structural thickening. The overlying Sourdough Hill Member is up to 900 m of predominantly graphitic schist with minor limestone beds.

Mineralization at Keno Hill exhibits a succession of hydrothermally precipitated minerals in veins from multiple pulses of hydrothermal events. The supergene alteration may have changed the mineralogy in the veins, although this material may have been removed by glacial erosion.

Silver occurs predominantly in argentiferous galena and argentiferous tetrahedrite (freibergite) with associated native silver. Other silver-bearing sulfosalts such as polybasite, stephanite, and pyrargyrite are also present. Lead occurs in galena and zinc in sphalerite which can be in iron-rich or iron-poor varieties. Other sulfides include pyrite, pyrrhotite, arsenopyrite, and chalcopyrite.

The Keno Hill deposit has been recognized as a polymetallic silver-lead-zinc vein style with characteristics similar to other known mining deposits such as the Kokanee Range (Slocan), British Columbia; Coeur d'Alene, Idaho; Freiberg and the Harz Mountains, Germany; and Příbram, Czech Republic.

1.4 EXPLORATION

The Keno Hill mining district exploration history dates to the beginning of the 1900s with early gold prospecting near the Mayo township. In 1903, the first silver mineralization was found followed by small-scale manual mining in 1913 at Silver King. United Keno Hill Mines (UKHM) undertook extensive exploration in Keno Hill until the mines closed and production stopped in 1989 (Cathro, 2006).

Exploration conducted by Alexco Resource Corp. after 2006 represented the first modern comprehensive exploration effort in Keno Hill since 1989. In the period from 2006 to 2022, Alexco completed surface exploration holes and underground drilling located at five main deposits comprising Bellekeno, Bermingham, Flame and Moth, Lucky Queen, and Onek. The focus of Alexco’s exploration drilling was primarily at, and adjacent to, historic mining areas.

In 2006, a wide-spaced district-scale aerial magnetic and electromagnetic geophysical survey and air photography was undertaken. Subsequent diamond drilling was conducted on targets from the geophysical survey assessed as having the potential for additional silver resources with work focusing on the Bellekeno, Silver King, and Lucky Queen mine areas.

Between 2006 and 2010, core was logged onto paper forms that were later entered into a commercial computerized logging program. More recently all logging data has been directly digitally entered into a SQL-based database.

In late 2018, Alexco undertook a detailed aerial RESOLVE EM-Magnetic geophysical survey over Galena Hill, later extended to cover Keno Hill in 2020. The survey provided detailed structural information that in addition to the district geologic mapping defines a general 1km periodicity of large-displacement northeast oriented transverse vein-faults that hosts mineralization assisting with the definition of drill targets. This structural understanding has substantially increased the success rate of intersecting mineralization with exploration drilling.

During 2020, Alexco commenced underground mining activities initially at Bellekeno and subsequently at the Bermingham and Flame and Moth deposits. The commencement of mining development shifted the focus of exploration drilling into areas adjacent to the previously outlined resources.

In 2021, Alexco conducted a directional drilling program which included 17,742 m of directional drilling at Bermingham Northeast Deep zone. During 2021 and 2022, Alexco suffered delays to both mining and exploration due to COVID-19 isolation restrictions and reduced staffing of personnel which resulted in lower productivity.

In early September 2022, the ownership of the Keno Hill Mine passed to Hecla while mining operations and exploration drilling activity continued through the change of ownership period.

Under Hecla, exploration drilling was maintained near the Bermingham underground mine development and at Coral Wigwam and Hector-Calumet.

Face sampling of underground mining production has been conducted for each heading advance ranging from 1.5 m to 3 m. The underground face sample data has not been incorporated into the resource estimation except at the Bellekeno deposit.

As part of its regular procedures, Hecla maintains standard logging and sampling conventions to capture information from its drilling programs.

1.5 MINERAL RESOURCE ESTIMATES

The Keno Hill 2023 Mineral Resource Estimate comprises five discrete estimates from the following areas: Bellekeno, Lucky Queen, Flame and Moth, Onek, and Bermingham. These Mineral Resources have been estimated in compliance with the Securities and Exchange Commission requirements (SEC, 2018) and are reported in accordance with S-K 1300 regulations. Mineral Resources are not Mineral Reserves and do not have demonstrated economic viability.

Possible risk factors included in the rationale used and any mitigating factors established to reduce any risk have been investigated and were noted during a detailed review of the drilling databases, methods used to estimate density, the application of grade capping, methods for grade interpolation and the classification methodology for each of the mineral resources.

It is the opinion of the Mining Plus geology QP that the Mineral Resource models presented in this report are representative of the informing data and that the data is of sufficient quality and quantity to support the Mineral Resource estimate to the Classifications applied.

A summary of the Mineral Resources at Keno Hill is shown in Table 1-1 with an effective date of December 31, 2023. The Mineral Resource is considered potentially mineable through optimized underground mining methods. All Mineral Resources declared in this report are reported inside underground shapes optimized at an economic cut-off of CAD \$185/tonne.

Table 1-1 – Summary of Mineral Resources – December 31, 2023 – Hecla Yukon – Keno Hill Mine.

Category	Deposit	Mass (,000 t)	Ag (g/t)	Pb (%)	Zn (%)	Au (g/t)	Contained Silver (,000 oz)
Indicated	Bellekeno	-	-	-	-	-	-
	Lucky Queen	135	340	0.72	0.70	0.07	1,472
	Flame and Moth	1,629	256	0.87	3.37	0.21	13,389
	Onek	901	150	1.00	8.38	0.41	4,349
	Birmingham	1,421	322	0.92	0.81	0.06	14,716
	Total Indicated	4,086	258	0.91	3.49	0.20	33,926
Inferred	Bellekeno	372	229	0.75	3.98	-	2,735
	Lucky Queen	212	312	0.74	0.58	0.05	2,123
	Flame and Moth	184	207	0.32	3.04	0.15	1,220
	Onek	234	96	0.74	5.68	0.28	721
	Birmingham	1,571	495	1.42	0.77	0.10	24,991
	Total Inferred	2,573	384	1.13	1.83	0.10	31,791

Notes:

1. Classification of the Mineral Resource is in accordance with the S-K 1300 classification system.
2. Mineral Resources were estimated by Hecla and reviewed and accepted by Mining Plus.
3. Mineral Resources are reported in-situ and are exclusive of Mineral Reserves.
4. Mineral Resources are 100% attributable to Hecla.
5. Totals may not represent the sum of the parts due to rounding.
6. Mineral Resources were estimated using an NSR cut-off value of CAD 185/tonne and a minimum mining width of 1.5 m.
7. The Mineral Resource estimates for the Birmingham and Flame and Moth deposits have an effective date of December 31, 2023.
8. The Mineral Resource estimates for the Lucky Queen and Onek deposits have an effective date of January 3, 2017.
9. The Mineral Resource estimate for the Bellekeno deposit is based on an internal Mineral Resource estimate completed by Alexco Resource Corp. and externally audited by Mining Plus. This Mineral Resource estimate has been depleted to reflect all mine production from Bellekeno to the end of December 2021. Bellekeno deposit has an effective date of December 31, 2023.

1.6 MINERAL RESERVE ESTIMATES

The current Mineral Reserve Estimate, as prepared by Hecla and reviewed and accepted by Mining Plus, is effective as of December 31, 2023, and is summarized in Table 12-1.

Only Indicated Mineral Resources were converted to Mineral Reserves. Any Inferred Mineral Resources included within the Mineral Reserve designs are carried at zero grade.

Table 1-2 – Summary of Mineral Reserves – December 31, 2023, – Hecla Yukon – Keno Hill Mine.

Deposit	Class	Volume (m ³)	Mass (t)	Ag (g/t)	Pb (%)	Zn (%)	Au (g/t)	Ag (oz)
Lucky Queen	Proven	-	-	-	-	-	-	-
	Probable	37,055	103,365	948	2.03	1.06	0.09	3,151,253
Flame and Moth	Proven	-	-	-	-	-	-	-
	Probable	136,334	455,244	764	2.86	5.83	0.48	11,184,405
Birmingham	Proven	-	-	-	-	-	-	-
	Probable	438,155	1,318,748	961	2.85	1.51	0.15	40,732,370
Total	Proven							
	Probable	611,544	1,877,357	912	2.81	2.53	0.22	55,068,028

Notes:

1. Classification of Mineral Reserves is in accordance with the S-K 1300 classification system.
2. Mineral Reserves were estimated by Hecla and reviewed and accepted by Mining Plus.
3. The point of reference for the Mineral Reserves is defined at the point where the ore is delivered to the processing plant.
4. Mineral Reserves are 100% attributable to Hecla.
5. Mineral Reserves are estimated at an NSR cut-off value of CAD 350/tonne.
6. The NSR values reflect the discrete metallurgical responses for the Mineral Reserve blocks.
7. Mineral Reserves are estimated using metallurgical recoveries of 92.0% Ag, 25% Au, 4.0% Zn and 88% Pb for the silver lead concentrate and 5.24% Ag, 0% Au, 68% Zn and 4.0% Pb for the Zinc concentrate.
8. Mineral Reserves are estimated using long-term silver price of USD 17.00/oz, lead price of USD 0.90/lb, zinc price of USD 1.15/lb and a CAD:USD exchange rate of 1.30.
9. A minimum mining width of 3.5 m was used for all assets.
10. Rounding as required by reporting guidelines may result in apparent summation differences between tonnes, grade and contained metal content.

The Mineral Reserves have been classified in accordance with the definitions for Mineral Reserves in S-K 1300. Detailed information on mining, processing, and other relevant factors are contained in the following sections and combined demonstrate that Keno Hill Operation is an economically viable Property.

1.7 MINING METHODS

Keno Hill comprises five separate deposits including Bellekeno, Lucky Queen, Flame and Moth, Onek, and Birmingham. The location of the deposits is shown in Figure 13-1; the mill, administration, and shop complexes are located near the Flame and Moth Deposit.

All deposits are characterized by high grades, narrow vein widths, and challenging ground conditions.

The operations at Bellekeno deposit were suspended in 2021, and the mine was placed under care and maintenance. Onek is a historic mine with remnant Mineral Resources but is not currently planned to be reopened without further study. Birmingham and Flame and Moth deposits are operating, and Lucky Queen is in the advanced exploration stage. The Mineral Reserve is included in the Life of Mine Plan (LOM).

At Keno Hill, mining is currently undertaken using a mechanized cut and fill method (MCF). Where the ore width is wider than can be safely extracted in one cut, the ore will be mined in adjacent drifts. Lenses

are predominantly mined in a bottom-up sequence and filled with cemented rock fill (CRF) using a 3%-8% binder content. The 8% binder CRF is restricted to cuts which will form the back of an underhand stope — the initial cut of panels that are above others along the same vein. All other cut and fill excavations will use unconsolidated rock fill (URF) or 3% binder where an adjacent cut is to be mined.

The overall production schedule is based on feeding a consistent 400 to 550 tpd to the centrally located mill. The current LOM period is estimated to be eleven years ending in 2034. Underground Mineral Reserves totaling 1.88 Mt are expected to be mined over the entire LOM period.

1.8 MINERAL PROCESSING

The Keno Hill is a polymetallic silver-lead-zinc vein type mineralization. There are three deposits included in the mine plan and mill feed. Production commenced in 2023 with feed from the Bermingham deposit. The mine plan continues with the mill feed from Bermingham followed by ore from the Flame and Moth deposit, and finally from Lucky Queen. The mill ramps up to process ore at 400 tpd in the first three years before reaching the peak capacity of 550 tpd in year five.

Ore is crushed and then processed in a conventional flotation mill producing silver-lead concentrate and zinc concentrate. A simplified process flowsheet is included in Section 14.2. The constant concentrate grades and recoveries are detailed in Section 10. The total concentrate production and grades over the life of mine are shown in Table 1-3.

Table 1-3 – LOM Projected Concentrate Grades.

Concentrate	LOM
Silver Concentrate	
Dry tonnes	103,199
Ag g/t	15,269
Pb %	45
Zinc Concentrate	
Dry tonnes	68,748
Ag g/t	997
Pb %	4.02
Zn %	47

Notes:

1. Based on the Probable Mineral Reserves presented in Section 12 and the mine plan presented in Section 13.

The corresponding expected metallurgical recoveries and total recovered metal are shown in Table 1-4.

Table 1-4 – LOM Projected Concentrate Grades.

	Average Recovery (%)	Total Recovery
Into Ag-Pb Concentrate		
Ag	92.0	50.7 Moz
Pb	88.0	46,440 tonnes
Into Zn-Ag Concentrate		
Ag	4.0	2.2 Moz
Zn	68.0	32,311 tonnes

Note: based on the total Probable Mineral Reserves presented in Section 12 and mine plan presented in Section 13.

Concentrates are thickened, filtered, and trucked off site for sale. Tailings are also thickened, filtered, and stored in a dry stack tailing facility adjacent to the mill. Process water is stored in the mill pond adjacent to the mill complex and recycled to the plant for varied applications.

Hecla has completed all mill upgrades planned by Alexco, the former site operator.

1.9 INFRASTRUCTURE

There is considerable infrastructure on site from the previous Alexco mining operations.

In Elsa, there are administrative, training, and exploration offices. The nearby Flat Creek camp facilities include bunkhouses, a kitchen facility, recreation facilities, miners’ dry facilities, as well as houses at the old Flat Creek town site (part of Elsa). At the District mill, there are mine and mill offices, dry facilities, an assay lab, an equipment maintenance facility, a warehouse, and the mill and dry stack tailings facility (DSTF) complex.

Power, water, roads, and communications are in place and maintained throughout the site. There is a network of access roads and haul roads throughout the District. A bypass has been constructed around Keno City to reduce traffic and noise for the residents.

Offsite infrastructure includes highway access between Whitehorse and the Keno Hill site as well as to Skagway (for concentrate shipping). Hecla has an administrative office in Whitehorse. No additional offsite infrastructure is required for this operation.

DSTF Phase 2 construction is scheduled to start in summer 2024. The design is currently being revised to incorporate comments received from the Yukon Government. Design revisions include revisions to the seismic criteria and re-evaluation of geotechnical design under updated criteria.

The current permit limits for the Dry Stack Tailings Facility and the Waste Rock Dump Facility are insufficient to cover the planned waste rock and tailings produced over the LOM. Permitting studies are

underway and a reasonable timeframe has been identified in the LOM to obtain appropriate permits to establish additional facilities for tailings and waste rock dumps.

1.10 ENVIRONMENTAL STUDIES, PERMITTING, AND PLANS, NEGOTIATIONS, OR AGREEMENTS WITH LOCAL INDIVIDUALS OR GROUPS

Hecla is committed to operating in compliance with all regulations and standards of good practice for environmental, health, and safety. To uphold this commitment Hecla has developed and approved corporate policies for environmental, health and safety practices and has prepared a detailed management plan to facilitate the continuous improvement of its environment and health and safety performance. An Environmental Management System (EMS) is currently in the process of being implemented, completion is expected by the end of 2024.

The mine design meets current standards and the implementation of the proposed environmental and health and safety practices ensures that the Keno Hill Mine is prepared to meet future challenges.

Hecla, and its subsidiary ERDC are parties to the ARSA with the Government of Canada in which Hecla is responsible for the care, maintenance, and closure of the historical mines, with funding from the government and the company to address the historical liabilities. The commercial agreement also allows Hecla to undertake exploration of the AKHM site and undertake active mining. Under this agreement, Hecla is responsible for environmental assessment, permitting, compliance, and costs associated with its ongoing exploration and new mine development activities. Additionally, if a new mine is brought into production including the use of infrastructure associated with a historic mine, terrestrial liabilities (i.e., waste rock storage areas and roads) and water-related liabilities located within a designated “Production Unit” become the responsibility of Hecla. At this time, Bellekeno and Flame and Moth have been defined as one combined active Production Unit under the Bellekeno Production Unit. The Birmingham Production Unit notice was submitted to Crown-Indigenous Relations and Northern Affairs Canada (CIRNAC) and approved on November 24, 2023. When commercial ore production occurs at Lucky Queen a Production Unit would need to be declared. That Production Unit would encompass the Lucky Queen mining area that is reasonably expected to be affected by production-related activities, including production features authorized in required permits and surface and groundwater expected to be affected by the permitted activities. Liability for reclamation and closure of the defined Production Unit would fall to AKHM.

Hecla, along with territorial, federal, and First Nation governments, is also responsible for developing a District-Wide Reclamation Plan that addresses these historic environmental liabilities arising from past mining activities. Under the agreement, Hecla is indemnified from the historic environmental liabilities. The latest reclamation plan, revision 7, was prepared by Alexco and issued in October 2022. Currently, water treatment is carried out at five locations in Keno Hill (Galkeno 300, Galkeno 900, Silver King, Onek 400, and Valley Tailings), as required by the ERDC’s Water Licence QZ21-012.

Alexco developed a reclamation plan that was used by Hecla to acquire Water Licence QZ21-012 in April 2023. Hecla is working towards implementing this water license and reclamation plan.

Permits held by Hecla for the Property are sufficient to ensure that mining activities are conducted within the regulatory framework required by regulations. The QP notes that the Bellekeno, Bermingham, and Flame and Moth deposits have all permits and authorizations in place to commence or continue with full-scale mine production. The Bermingham deposit has the required permits which should allow it to sustain mine production for a number of years, however, it will require an amendment to include recent additions to the Mineral Reserve in Bermingham Deep Northeast Zone. In addition, it is likely that the Quartz Mining Licence (QML-0009) and the Water Licence QZ18-044 will need modifications in order to increase water discharge amounts/rates, increase the volume or change location of waste rock and tailings storage. The Lucky Queen deposit has in place a Quartz Mining Licence (QML-0009) which authorizes mining operations, but Water Licence QZ18-044 would require an amendment before water-based activities for Lucky Queen can proceed.

1.11 CAPITAL, AND OPERATING COST ESTIMATES

The Keno Hill Mine is currently producing and there is no pre-production capital. Capital costs over the LOM total USD 194.85 million and are summarized in Table 1-5.

Table 1-5 – Capital Cost Summary.

Capital Cost	\$M
Drilling	23.58
Mine Development, Rehab, Stripping	96.39
Mine Infrastructure	11.83
Mobile Equipment	38.43
Ore Processing	15.88
Reclamation and Closure	8.74
Total Capital Costs	194.85

The forecasted LOM operating costs totaling \$257.4/t milled are summarized in Table 1-6.

Table 1-6 – Overall Operating Cost Estimate.

Operating Cost	\$/t milled	\$M
Mining	130.05	244.1
Milling	47.04	88.3
G&A	80.35	150.8
Total Operating Costs	257.43	483.3

Hecla-forecasted capital and operating costs estimates are derived from annual budgets and historical actuals over the life of the current operation and other Hecla owned operations. According to the American Association of Cost Engineers (AACE) International, these estimates would be classified as Class 1 with an accuracy range of -3% to -10% to +3% to +15%, for Birmingham and Flame and Moth deposits and an AACE Class 3 estimate with an accuracy of -10% to -20% on the low side and +10% to +30% on the high side for the Lucky Queen deposit.

1.12 ECONOMIC ANALYSIS

Please refer to the note regarding forward-looking information at the front of this Report. The economic analysis contained in this TRS is based on the Keno Hill Mine Probable Mineral Reserves material only, economic assumptions, and capital and operating costs provided by Hecla’s technical team in its LOM plan model and reviewed by the QPs. All costs in this section are expressed in US dollars (USD), unless otherwise stated. All costs in this section of the TRS are expressed without allowance for escalation or currency fluctuation. Where required, costs quoted in Canadian dollars (CAD) were converted to USD at an exchange rate of USD 1.00 = CAD 1.35.

The results of this economic analysis represent forward-looking information. The results depend on the inputs that are subject to several known and unknown risks, uncertainties, and other factors that may cause actual results to differ materially from those presented in this section. Information that is forward looking includes Mineral Reserve estimates, commodity prices, the proposed mine production plan, projected recovery rates, proposed capital and operating cost estimates, closure cost estimates, and assumptions on geotechnical, environmental, permitting, royalties, and hydrogeological information.

An economic analysis was undertaken on a 100% project ownership basis to determine pre-tax and post-tax net present value (NPV). The operation consists of an eleven-year mine life producing between 400 and 550 tpd mill feed.

A summary of the key project criteria is provided in the subsequent subsections.

1.12.1 REVENUE

For the purposes of this economic analysis described in this section, revenue is estimated over the LOM with a flat long-term price of USD 22.00/oz Ag, USD 0.95/lb Pb and USD 1.15/lb Zn. Mining Plus's QP considers these prices to be aligned with end of year 2023 industry consensus long term forecast prices. Payable metals in the Keno Hill Mine 2023 plan are estimated at 95.0% Ag and 93.3% Pb in the silver-lead concentrate and 83% Zn and 70% Ag in the zinc concentrate.

LOM net revenue is USD 1,118 million (after Refining Charges and Royalty).

1.12.2 TAXATION AND ROYALTIES

- There is an NSR royalty of 1.5% payable to the Government of Canada.
- Approximately CAD 1.2 million of the total CAD 4.0 million has been paid or accrued for as of the date of this Report.
- Taxes include Quartz Mining Tax, federal, and Yukon Taxes. It is assumed that the three operating deposits are treated as 'one mine' for income tax and royalty tax purposes.

1.12.3 CASH FLOW ANALYSIS

The Hecla post tax financial analysis QP has reviewed Hecla's Keno Hill Mine LOM 2024 Reserves only model and has prepared its own unlevered after-tax LOM cash flow model based on the information contained in this TRS to confirm the physical and economic parameters of the Keno Hill Mine.

The Keno Hill Mine economics have been evaluated using the discounted cash flow method by considering annual processed tonnages and grades of ore. The associated process recovery, metal prices, operating costs, refining and transportation charges, and sustaining/growth capital expenditures were also considered.

The economic analysis results, presented in Table 1-7 in USD with no allowance for inflation, show a pre-tax and after-tax NPV, using a 5% discount rate of \$318.1 million and \$304.5 million, respectively. The Hecla post tax financial analysis QP is of the opinion that a 5% discount rate for after-tax cash flow discounting of an active Canadian precious/base metal operations in a politically stable region is reasonable and appropriate, and commonly used. For this cash flow analysis, the internal rate of return (IRR) and payback are not applicable since the Keno Hill Mine has been producing and selling concentrate for a number of years under Hecla and previous ownership. Please refer to the note regarding forward-looking information at the front of the Report.

Table 1-7 – Financial Summary.

Item	Unit	LOM Total
Life of Mine	years	11.0
Production		
Ore Milled	'000 tonnes	1,877
Waste Mined	000 tonnes	1,275
Silver Grade	g/t	912
Gold Grade	g/t	0.22
Lead Grade	%	2.81
Zinc Grade	%	2.53
Contained Metal in Mine Production		
Silver	koz	55,068
Gold	oz	0
Lead	tonnes	52,772
Zinc	tonnes	47,517
Produced Metal		
Silver	koz	52,865
Lead	tonnes	49,205
Zinc	tonnes	34,212
Metal Prices		
Silver	\$/oz	22.0
Lead	\$/oz	0.95
Zinc	\$/oz	1.15
Gross Revenue		
Gross Revenue	\$ million	1,252
Treatment and Refining Charges	\$ million	131.8
Royalty	\$ million	2.1
Costs		
Capital Costs	\$ million	194.8
Operating Costs	\$ million	483.3
Financial Summary		
Pre-Tax Undiscounted Cash Flow	\$ million	439.5
Pre-Tax NPV at 5%	\$ million	318.1
Taxes	\$ million	19.7
After-Tax Undiscounted Cashflow	\$ million	419.8
After Tax NPV 5%	\$ million	304.5

1.13 CONCLUSIONS

The Keno Hill is a polymetallic silver-lead-zinc vein type mineralization. There are three deposits included in the mine plan and mill feed. Production commenced in 2023 with feed from the Bermingham deposit. The mine plan continues with the mill feed from Bermingham and the Flame and Moth deposits, and finally from Lucky Queen. The mill ramps up to process ore at 400 tpd in the first three years before reaching the peak capacity of 550 tpd in year five. The current LOM period is estimated to be eleven years ending in 2034.

The mining method at the Keno Hill Mine is overhand mechanized cut and fill using cemented and uncemented rockfill as backfill. Mechanized cut and fill is a highly selective method that enables extraction of the Mineral Reserves safely and economically while adapting to the variable nature of the narrow vein geometry. Hecla has maintained an active drilling program that seeks to identify mineralization extensions and to support the evaluation of Mineral Resources and provide grade control definition ahead of mining operations. Mining Plus considers the drilling, logging and drill core meet existing industry standards and are sufficient to support Mineral Resource Estimation.

The crushed ore is processed in a conventional flotation mill producing silver-lead concentrate and zinc concentrate. The total concentrate production over the life of mine is 103.2 kt at Ag 15,269 g/t and Pb 45.0%, and 68.7 kt at Ag 997 g/t and Zn 47.0% of silver and zinc concentrates respectively.

In terms of project execution, Hecla has been able to leverage the existing infrastructure onsite to resume mining and milling operations and the positive economic results support the updated Mineral Reserves Estimate.

1.14 RECOMMENDATIONS

Mining Plus outlines the recommendations in the following subsections.

1.14.1 GEOLOGY AND MINERAL RESOURCES

- Mining Plus has recommended that the current data spacing, and distribution is maintained at all deposits and suggested monitoring the subsequent geological and grade continuity to ensure it continues to be appropriate for Mineral Resource Estimation.
- Review the logging disparities identified in drillings conducted before 2010 and conduct a comprehensive assessment of logging consistency across various drilling campaigns. This review aims to enhance the interpretation and modeling criteria for mineralized structures.
- Discrepancies observed between the entered assay data and the laboratory certificates were noted in the Onek database, and to a lesser extent at Bellekeno and Lucky Queen. Mining Plus

considers that a more comprehensive audit be conducted to address these inconsistencies and verify if any other issues exist.

- Constant monitoring of the pulp bulk density is recommended by conducting checks using the paraffin wax method on samples estimated using the Archimedes density method. The checks will provide information on any relevant biases and must be included in the company's procedures.
- Mining Plus considers that adjustments to the procedures for underground face sampling and an improvement in onsite assaying may be sufficient to support the incorporation of face samples within future grade estimation processes. Face samples are normally reliable source data for estimations as they can be controlled at uniform boundaries and set locations within the mining development. Face sample data represents the closest spaced samples that can be used to determine local grade variability or continuity.
- Mining Plus recommends the following improvements to the Quality Control program:
 - Hecla should include an investigation of the origin of any quality control failures and to implement timely corrective measures.
 - Hecla should continue to incorporate field duplicates, pulp duplicates and umpire check samples as essential parts of the Quality Control procedure to assess the precision of samples at various stages of sampling and comminution.
 - The incorporation of pulverized blank standard samples is recommended to evaluate contamination during the analysis stage.
- The applied geological interpretation and modelling criteria should be clearly defined and consistent during the interpretation of each structure and deposit, which will help improve precision in locally estimated resources.
- It is recommended that future resource estimates should establish clear and consistent estimation criteria as far as practicable, including:
 - An update of the estimated resources at Onek, Lucky Queen and Bellekeno, with appropriate documentation and traceability of the data and information used.
 - The block model should use parent cells and sub cells to facilitate underground optimizations.
 - A consistent capping method be applied uniformly across all deposits. The recommended approach is to consider capping after the compositing process, where the influence of high grades is mitigated.
 - The NSR economic cut-off should be based on Hecla's current costs, which should include at a minimum the cost of mine and mineral processes, which can be tangible and realistic depending on the level of knowledge of mining development in the area.
- Monitor the estimation results of those domains with no record (NR or NULL) intervals mainly in Flame and Moth, to see potential risks in this area resulting from these samples.
- Continue with the Resource classification criteria for Indicated Resources using a distance of 25 m, which should be consistent wherever possible for all deposits.
- Implement mining reconciliation practices that help to better understand the veracity of mineral resource estimates and anticipate future improvements.

1.14.2 MINING AND MINERAL RESERVES

The QP notes that the overall mine plan benefits from increased flexibility and working fronts as the mine matures and the capital development advances. In the initial years, there is an opportunity to further de-risk the overall LOM plan and better predict the operational performance of future mining zones by addressing the following items:

- Undertake a more detailed dilution and extraction study, including consideration of any existing reconciliation studies, to better quantify the extraction recovery, dilution, and other modifying factors that Hecla is currently applying to all production designs. Specifically, the final cut underneath a planned sill can be expected to have a higher dilution from CRF failure due to blasting cycles of the final lift and previous lift. Use the results of the above noted studies to determine the actions necessary to align mine production grades with the Mineral Reserve Estimates.
- Complete additional geotechnical assessments to determine the amenability of the orebody to more productive and less costly mining methods. Hecla is reviewing opportunities to trial long hole stope mining methods in the Flame and Moth mine between 2024 and 2026 to refine the method and application without affecting the overall LOM plan. The outcomes of these trials should be incorporated into future reserve estimates.
- Complete additional optimization on the Mineral Reserve mine plan and de-risk the mine plan on a development basis by assessing the potential for slower than planned increases to efficiency and underground unit development operations or rates. Complete additional scenario scheduling to better understand the risk and plan appropriately to meet the schedule.
- Continue evaluating the option of mining at Flame and Moth earlier than planned as a large portion of the underground access has been completed and the mine is ready to produce ore with minimal development. This will assist with reducing the LOM plan risk by creating additional mining fronts with minimal upfront capital.
- Continue conducting definition diamond drilling throughout the remainder of the underground mining operation to convert Inferred to Indicated Mineral Resources and increase the understanding of the mineralization. Doing so may result in increased Mineral Reserves near planned capital and operational development and reduce the overall capital development intensity of the schedule.
- Investigate adding marginal underground Indicated Mineral Resources to the Mineral Reserves where appropriate.
- Complete hydrogeological studies to better understand the sources of water at Flame and Moth and Birmingham.
- Review mining plans and benchmark other relevant Hecla operations to define definitive actions to attain the planned improvements in mining productivity, daily development advance and associated costs over the first four years.

1.14.3 MINERAL PROCESSING

Sedgman's QP considers that there is an opportunity to improve the level of detail of the metallurgical predictions and particularly the concentrate production at a month-to-month operational level. Further locked cycle tests at the next stage of study are recommended for samples representing the Flame and Moth deposit and different blends according to the LOM production plan. There may be an opportunity to improve the concentrates grades with further testing, particularly of the zinc concentrate. Additional metallurgical testing at different head grades would also support the approach to capping recoveries, particularly for the compartment of lead to concentrates at lower head grade mill feed. In addition, further hardness tests are recommended on these samples to verify potential grindability variations for future mill feeds. It is also recommended that testing of the increased plant throughout above the 400 tpd be done in the first year of operation to identify potential bottlenecks and confirm requirements for mill modifications to achieve the 550 tpd throughput. Sedgman recommends that Hecla perform a series of debottlenecking exercises and productivity tests on the mill prior to and well in advance of the expected throughput increases. This will help to de-risk the production profile and ensure a smooth ramp up.

1.14.4 ENVIRONMENTAL STUDIES, PERMITTING, SOCIAL OR COMMUNITY IMPACTS

The QP notes that the Mineral Reserves contain material that is not fully permitted for extraction at both Bermingham (Bermingham Deep Northeast Zone) and Lucky Queen. In addition, the current permit limits for the Dry Stack Tailings Facility and the Waste Rock Dump Facility are insufficient to cover the planned waste rock and tailings produced over the LOM.

The QP recommends that Hecla continue with its planned permit approvals and amendment process to reduce the risk to the overall mine plan and investigate alternatives if required.

1.14.5 ECONOMICS ANALYSIS

The QP is of the opinion that as Keno Hill is an operating mine within a relatively stable tax jurisdiction, and the information contained in Section 19.4 Economic Analysis accurately represent the current conditions at the mine. As such, the QP has no additional material recommendations to make.

2. INTRODUCTION

2.1 TERMS OF REFERENCE AND PURPOSE OF THE REPORT

Mining Plus Canada Ltd. (Mining Plus) was retained by Hecla to prepare a Technical Report Summary on the Keno Hill Mine (KHM). The purpose of this TRS is to support the disclosure of the Keno Hill Mineral Resource and Mineral Reserve estimates as of December 31, 2023. This TRS conforms to the United States Securities and Exchange Commission’s (SEC) Modernized Property Disclosure Requirements for Mining Registrants as described in Subpart 229.1300 of Regulation S-K, Disclosure by Registrants Engaged in Mining Operations (S-K 1300) and Item 601 (b)(96) Technical Report Summary. Mining Plus visited the Property on October 23 to 26, 2023.

Hecla is a public company, established in 1891, it has headquarters in Coeur d’Alene, Idaho, USA. Hecla owns a 100% interest in the mineral rights for the Keno Hill through its subsidiaries following its successful acquisition of Alexco in September 2022. Elsa Reclamation & Development Company Ltd. (ERDC), an indirect wholly owned subsidiary of Hecla, continues to advance the development and eventual implementation of the District Wide Closure Plan (ESM Reclamation Plan) which addresses the historic environmental liabilities of the district from past mining activities. The potential liabilities associated with the historic operations in Keno Hill are indemnified by the Government of Canada under the terms and conditions of the commercial agreement subject to the requirement for ERDC to develop, permit and implement the site Reclamation Plan.

Keno Hill is located within the Keno Hill Silver District in Canada’s Yukon Territory. The Property is situated 350 kilometers (km) north of Whitehorse and lies within the traditional territory of the First Nation of Na-Cho Nyäk Dun. It comprises 242 square kilometers (km²) with numerous mineral deposits and more than 35 historical past-producing mine sites. The property includes Bellekeno, Lucky Queen, Flame and Moth, Onek, and Bermingham deposits and a processing plant (District Mill) along with associated infrastructure. The site is currently operating one underground deposit (Bermingham) and has plans to commence operations in Flame and Moth and Lucky Queen deposits as part of the LOM plan. The operations mine silver, lead, zinc, and gold which is processed to produce silver-lead and zinc concentrates.

In 2010, Alexco constructed a 408 tpd capacity conventional flotation processing plant and they commenced mining at the Bellekeno deposit.

Following the acquisition of Alexco Resource Corp. in September 2022, Hecla focused effort on development activities at Bermingham and Flame and Moth deposits. In 2023, Hecla restarted ore production at both deposits. Flame and Moth production was idled in September 2023 to focus on production and development of the Bermingham deposit but could be restarted to support mill production at any time.

This Report contains forward-looking information; refer to the note regarding forward-looking information at the front of this Report.

2.2 QUALIFICATIONS OF QUALIFIED PERSONS/FIRMS AND SITE VISIT

2.2.1 QUALIFIED PERSONS OR FIRMS

The qualified persons (QP) preparing this technical report are specialists in the fields of geology, exploration, Mineral Resource and Mineral Reserve estimation and classification, underground mining, geotechnical, environmental, permitting, metallurgical testing, mineral processing, processing design, capital and operating cost estimation, and mineral economics.

The following serve as the qualified persons or qualified firms for this Report in compliance with 17 CFR § 229.1302 (b)(1)(i) and (ii) qualified person definition:

- Mining Plus Canada Ltd.
- Ms. Christina Vink, P.Eng. of Sedgman Canada Ltd.
- Mr. Baoyao Tang, P.Eng. of Hecla Yukon
- Mr. Matthew Blattman, PE of Hecla.

The QPs have supervised the preparation of this Report and take responsibility for the contents of the Report as set out in Table 2-1. The Date and Signature summary can be found in Section 26 Date and Signature Page.

Table 2-1 – Report Contributors and Responsibility.

Qualified Person or Firm	Report Responsibilities	Report Sections
Mining Plus Canada Ltd.	Geology, Mineral Resource Estimate, Mine Design, Mineral Reserve, market studies, mining capital costs and operating costs, pre-tax economics	1.1, 1.2, 1.3, 1.4, 1.5, 1.6, 1.7, 1.10, 1.11, 1.12.1, 1.13, 1.14.1, 1.14.2, 1.14.4, 2, 3, 4, 5, 6, 7, 8, 9, 11, 12, 13, 16, 17, 18, 19.1, 19.2, 19.3, 20, 21, 22.1, 22.2, 22.3, 22.6, 22.7, 23.1, 23.2, 23.3, 23.5, 24, 25
Ms. Christina Vink, P.Eng.	Metallurgy, mineral processing, recovery methods, infrastructure (excludes waste rock management and Dry Stack Tailings Facility (DSTF))	1.8, 1.9 (excludes waste rock management and DSTF), 1.14.3, 10, 14, 15.1, 15.2, 15.3, 15.4, 15.5, 22.4, 22.5, 23.4
Mr. Baoyao Tang, P.Eng.	Dry Stack Tailings Facility and waste rock management	1.9 (waste rock management and DSTF only), 15.6, 15.7
Mr. Matthew Blattman, PE	Post-tax financial model and economics	1.12.2, 1.12.3, 19.4, 19.5, 19.6, 22.8, 23.6

Mining Plus Canada Ltd. is a mining technical services provider, consisting of professionals specializing in geology, mining engineering (Surface and Underground), geotechnical engineering, mine ventilation and operational management. Mining Plus has grown and diversified over the years to cover a broad range of mineral commodities across the project value chain, from the conceptual stage of projects, right through to feasibility study work, project delivery, commissioning, and mine closure.

Ms. Christina Vink with Sedgman Canada Ltd. is a Professional Engineer (P.Eng.) of Engineers and Geoscientists British Columbia and a Registered Professional (No. 171306) in British Columbia. Ms.

Christina Vink is an independent consultant to the Commodity industry and a Qualified Person (QP) as defined by 17 CFR §229.1302 (b)(1)(i). Ms. Christina Vink graduated from the University of Dalhousie with a Bachelor of Applied Science in Chemical Engineering in 2012. Ms. Christina Vink has been directly involved with metallurgical test work and flowsheet development from preliminary testing through to detailed design and process optimization over the last 12 years working on projects in Canada and the United States. Her roles have included providing advice on process flowsheet development, undertaking, and managing process optimization improvements, installing process plant circuit equipment, supervising metallurgical modeling, and the development of test programs.

Mr. Baoyao Tang, P.Eng. is the Chief Mine Engineer for Hecla’s Keno Hill Mine. He has over 30 years of experience working in the mining industry in China and Canada in coal, uranium, potash, gold, silver, lead, and zinc deposits on various scopes involving planning, geotechnical engineering, and project management. He holds a Bachelor of Engineering in Mine Construction Engineering from the Shandong University of Mining Technology, Tai’An, China, a Master of Engineering in Mine Construction Engineering from the China University of Mining Science and Technology, Beijing, China, and a Ph.D. in Mine Engineering from the McGill University, Montreal, Canada. He is registered as a Professional Engineer (P.Eng.) with Engineers and Geoscientists of British Columbia, Canada and with Engineers Yukon, Canada. In his role with Keno Hill Operations, he provides technical support and collaborates with site staff on mine design and planning, geotechnical engineering for both underground and surface infrastructures. He has worked at the Keno Hill Mine since April 2022 to the present and has inspected the property on multiple occasions. His most recent inspection to the property was January 28, 2024.

Matthew Blattman, PE, is the Director – Technical Services at Hecla’s corporate office. He has over 28 years of experience working in large and small underground and open pit operations in North, Central and South America as well as Northern Europe. He holds a Bachelor of Science in Mining Engineering from the University of Nevada (Mackay School of Mines) and is registered as a Professional Engineer (PE) in the state of Nevada. Mr. Blattman is a Registered Member of the Society of Mining, Metallurgy and Exploration (RM-SME). In his role with Hecla, he leads the Corporate Technical Services group in supporting the operating sites with mine planning, geotechnical, metallurgical, and capital projects. He has visited the site multiple times in his role at Hecla over the period of March 2022 to December 2023.

2.2.2 SITE VISIT

Mining Plus most recently visited the site between October 22 to 25, 2023. During this site visit, Mining Plus Qualified Persons (QP) received a project overview by site management with specific activities as follows:

- The Mining Plus geology QP conducted a comprehensive tour of various geological information collection areas. This included a visit to the logging room, where she held discussions with the technical staff on topics such as geological context, deposit type, mineralization, logging processes, sampling process, chemical analysis methods, quality control, and chain of custody.

Additionally, discussions encompassed the procedures of the previous owner (Alexco) and the historical data. A visit of core storage facilities, reject samples, and pulp samples, inspection of ongoing diamond drilling on the surface and at the old pit. Underground tours to observe structures and mineralization and a visit to the in-house laboratory, where the applied methodology and its impact on mining reconciliation results were discussed.

- The Mining Plus mining QP visited production, development, and critical infrastructure areas in the Bermingham and Flame and Moth underground deposits. Overhand cut and fill/drift and fill production areas were visited where discussions were carried out on the mining cycle, backfill, productivities, dilution, and recovery. The QP discussed mining methods, planning, and scheduling activities, mobile equipment, ventilation, egress, services and geotechnical procedures with relevant site and supervisory personnel.
- The Mining Plus mining QP visited surface facilities/operations around the District Mill site, Dry Stack Tailings Facility (DSTF) and Bermingham deposit and interviewed environmental and applicable staff for environmental/social management systems, permitting and compliance programs, reclamation/closure plans and associated budget.
- Ms. Christina Vink, P.Eng., the processing QP, did not visit the site as it was deemed a desktop review of the current mill operations data and correspondence with relevant site personnel would suffice for purposes of this Technical Report Summary.
- Mr. Baoyao Tang, P.Eng., QP for the Dry Stack Tailings Facility and the waste rock storage areas, has completed a personal inspection of the Property on multiple occasions from the April 2022 to January 2024 and he is currently engaged in site based rotational employment at the Property.
- Mr. Matthew Blattman, PE, QP for the post-tax economic model and cashflow analysis, has completed a personal inspection of the Property on multiple occasions from March 2022 to December 2023.

2.3 EFFECTIVE DATE

The Effective Date of this TRS is December 31, 2023.

2.4 PREVIOUS TECHNICAL REPORTS

This S-K 1300 Technical Report Summary is the first that has been prepared by Hecla for the Keno Hill Mine. Thus, this report is not an update of a previously filed Technical Report Summary under the S-K Regulations.

However, multiple technical reports on Keno Hill have been published between 2011 and 2021:

- Technical Report on the Lucky Queen Deposit, Lucky Queen Property, Keno Hill District, Yukon, prepared by SRK Consulting in 2011 (SRK, 2011a).

- Technical Report on the Onek Deposit, Keno Hill District, Yukon, Onek Property, Keno Hill District, Yukon, prepared by SRK consulting in 2011 (SRK, 2011b).
- Technical Report on the Flame & Moth Deposit, Flame & Moth Property, Keno Hill District, Yukon, prepared by SRK Consulting in 2012 (SRK, 2012a).
- Technical Report on the Bermingham Deposit, Bermingham Property, Keno Hill District, Yukon, prepared by SRK Consulting in 2012 (SRK, 2012b).
- Updated Technical Report on the Flame & Moth Deposit, Flame & Moth Property, Keno Hill District, Yukon, prepared by SRK Consulting in 2013 (SRK, 2013).
- Updated Preliminary Economic Assessment for the Keno Hill Silver District Project – Phase 2, Yukon, Canada, prepared by SRK Consulting in 2014 (SRK, 2014).
- Technical Report Preliminary Economic Assessment of the Keno Hill Silver District Project, Yukon Territory, Canada, prepared by RPA in 2017 (RPA, 2017).
- NI-43101 Pre-feasibility Study the Keno Hill Silver District Project, Yukon Territory, Canada, prepared by Mining Plus in 2019 (Alexco, 2019b).
- NI-43101 Pre-feasibility Study the Keno Hill Silver District Project, Yukon Territory, Canada, amended on February 13, 2020 (Alexco, 2020).
- NI 43-101 Technical Report on Updated Mineral Resource and Reserve Estimate of the Keno Hill Silver District. Prepared by Mining Plus in 2021 (Alexco, 2021b).

2.5 SOURCE OF INFORMATION

This report has been prepared by Mining Plus Canada Consulting Ltd. (Mining Plus) for Hecla. The information, conclusions, opinions, and estimates contained herein are based on:

Information available to Mining Plus at the time of preparation of this report including supporting information from report titled: “NI 43-101 Technical Report on Updated Mineral Resource and Reserve Estimate of the Keno Hill Silver District, dated May 26th, 2021, prepared by Mining Plus and filed with the Canadian Securities Exchange System for Electronic Document Analysis and Retrieval (SEDAR) and internal (Hecla) technical reports.

- Documentation for licensing and permitting, published government reports, and public information as included in the References section of this report (Section 0) and cited in this report.
- Assumptions, conditions, and qualifications as set forth in this report.
- Data, reports, and other information supplied by Hecla and other third-party sources as listed below.

Discussions in relation to past and current operations at the Keno Hill Mine were held with the following personnel:

- Mr. Keith Blair, Chief Geologist, Hecla.

- Mr. Wes Johnson, Chief Engineer, Hecla.
- Mr. Matthew Blattman, Director – Technical Services, Hecla.
- Mr. Zach Ward, Senior Mining Engineer, Hecla.
- Mr. Benjamin Chambers, Corporate Resource Geologist, Hecla.
- Mr. Seymour Iles, Keno Hill District Exploration Manager, Hecla Yukon.
- Mr. Shawn Pelechaty, Mill Manager, Hecla Yukon.
- Mr. Derrick Colquhoun, Mill Superintendent, Hecla Yukon.
- Mr. Mike Tanasa, Senior Mine Engineer, Hecla Yukon.
- Mr. Justin Patterson, Technical Services Manager, Hecla Yukon.
- Mr. Scott Snider, Senior Geologist, Hecla Yukon.
- Mr. Kevin Eppers, Environmental Manager, Hecla Yukon.
- Ms. Arlene Stearman, Senior Environmental Coordinator, Hecla Yukon.
- Mr. Sebastien Tolgyesi, Assistant GM, Hecla Yukon.
- Ms. Lorelee Johnston, Director Indigenous Affairs & Canadian Community Relations, Hecla Yukon.
- Mr. Gordon Wong, Director of Finance, Hecla Canada Ltd.
- Mr. Samuel Santos, Site Controller, Hecla Yukon.
- Ms. Lori Paslawski, Senior Exploration Geologist, Hecla Yukon.

The third-party sources providing information in support of this document are:

- SRK Consulting (Canada) Inc.
- Tetra Tech (Canada).

Geotechnical parameters:

- Keno Hill Silver District-Pre-Feasibility Study Geotechnical Engineering. Project No. DMNY5500 Rev #2 March 21, 2019, prepared by Jacobs Engineering Group Inc.

Metallurgical laboratory testing including:

- An Investigation into The Flotation of Samples from The Bermingham and Christal Zone Deposits, prepared for Alexco Resource Corp. Project 15774-002 – SGS Final Report #2 March 15, 2019, prepared by SGS Canada Inc.
- An Investigation into the Flotation of Samples from the Bermingham Deposit, prepared for Alexco Resource Corp. Project 15774-001 – SGS Final Report October 25, 2018, prepared by SGS Canada Inc.
- An Investigation into The Comminution and Flotation of Samples from the Lucky Queen and Flame and Moth Deposits prepared for Alexco Resource Corp. Project 15774-002 – SGS Final Report, November 29, 2018.

2.6 UNITS OF MEASURE AND GLOSSARY OF TERMS

Units of measurement used in this TRS conform to the metric system unless otherwise noted.

All currency in this TRS is United States dollars (USD) unless otherwise noted. Canadian dollars (CAD) have been converted to United States dollars at an exchange rate of USD 1.00 = CAD 1.35 unless otherwise noted. Table 2-2 includes a full list of abbreviations used in this report and their associated definitions.

Table 2-2 – List of Abbreviations, Acronyms and Their Associated Definition.

Item	Definition	Item	Definition
°C	degree Celsius	m ³	cubic meter
°F	degree Fahrenheit	m ³ /h	cubic meters per hour
µm	micrometer	m ³ /s	cubic meters per second
a	annum	Ma	mega-annum/million years ago
A	ampere	MASL	meters above sea level
AKHM	Alexco Keno Hill Mining Company Ltd.	MCF	mechanized cut and fill
ARSA	Amended and Restated Environmental Subsidiary Agreement	mi	mile
bbl	barrels	min	minute
Btu	British thermal units	mm	millimeter
BWI	Bond Ball Mill Work Index	mph	miles per hour
C\$	Canadian dollars	MVA	megavolt-amperes
cal	calorie	MW	megawatt
CCBA	Comprehensive Cooperation and Benefits Agreement	MWh	megawatt-hour
cfm	cubic feet per minute	N-AML	non-acid material leaching
CIRNAC	Crown-Indigenous Relations and Northern Affairs Canada	NP	neutralizing potential
cm	centimeter	NPV	net present value
cm ²	square centimeter	NTS	National Topographic System
COSEWIC	Committee on the Status of Endangered Wildlife in Canada	OMS	Operation, Maintenance, and Surveillance
CRF	cemented rock fill	oz	Troy ounce (31.1035 g)
CRIRSCO	Committee for Mineral Reserves International Reporting Standards	oz/st, opt	ounce per short ton
d	day	P-AML	potentially-acid material leaching
DCF	discounted cash-flow	PLC	programmable logic controller
dia	diameter	ppb	part per billion
DIAND	Department of Indian Affairs and Northern Development	ppm	part per million
dmt	dry metric tonne	PRA	Inspectorate America Corporation
DSTF	dry stack tailings facility	psia	pound per square inch absolute
dwt	dead-weight tonnage	psig	pound per square inch gauge
EOM	end of mine life	QEMSCAN	quantitative evaluation of materials by scanning electron microscopy

Item	Definition	Item	Definition
ERDC	Elsa Reclamation & Development Company	QMA	Quartz Mining Act
FNNND	First Nation of Na-Cho Nyäk Dun	QML	Quartz Mining Licence
ft	foot	RCP	reclamation and closure plan
ft/s	foot per second	RL	relative elevation
ft ²	square foot	ROM	run of mine
ft ³	cubic foot	RQD	rock quality designation
FW	footwall	s	second
g	gram	S&A	Starkey & Associates
G	giga (billion)	SGS	SGS Canada Inc.
G&A	General and Administrative	SI	slope indicator
g/L	gram per liter	st	short ton
Gal	Imperial gallon	stpa	short ton per year
Gpm	Imperial gallons per minute	stpd	short ton per day
gpt	gram per tonne	t	metric tonne
gr/ft ³	grain per cubic foot	TMP	tailings management plan
gr/m ³	grain per cubic meter	TRS	technical report summary
GTC	ground temperature cable	tons	short tons
ha	Hectare	tpa	metric tonne per year
hp	Horsepower	tpd	metric tonne per day
hr	hour	TYC	Treadwell Yukon Company Limited
HW	hanging wall	UKHM	United Keno Hill Mines
Hz	hertz	URF	uncemented rock fill
ICP	inductively coupled plasma	USD	United States dollar
in.	inch	Usg	United States gallon
in ²	square inch	Usgpm	US gallon per minute
J	joule	V	volt
k	kilo (thousand)	W	watt
kcal	kilocalorie	wmt	wet metric tonne
kg	kilogram	WRDA	waste rock disposal area
km	kilometer	WRSF	waste rock storage facility
km/h	kilometer per hour	wt%	weight percent
km ²	square kilometer	WTF	water treatment facility
kPa	kilopascal	WUL	Water Use Licence
kVA	kilovolt-amperes	WWI	First World War
kW	kilowatt	WWII	Second World War
kWh	kilowatt-hour	yd ³	cubic yard
L	liter	YESAA	Yukon Environmental and Socio-economic Assessment Act
L/s	liters per second	YG	Government of Yukon
lb	pound	yr	year
LCT	locked cycle flotation test	μ	micron

Item	Definition	Item	Definition
m	meter	µg	microgram
M	mega (million); molar	µm	micrometer
m ²	square meter		

3. PROPERTY DESCRIPTION

3.1 PROPERTY LOCATION, COUNTRY, REGIONAL, AND GOVERNMENT SETTING

The Keno Hill Mine is located in the central Yukon Territory, Canada, and covers an area of approximately 15,000 ha (Figure 3-1) in central Yukon (63° 54' 32" N, 135° 19' 18" W; NTS 105M/14 and 105M/13). The operations are located in the traditional territory of the First Nation of Na-Cho Nyäk Dun (FNNND).

Access to the property is via the Alaska Highway from Whitehorse to Stewart Crossing (354 km), then from Stuart Crossing to Mayo via the Silver Trail Highway (53 km), and an all-weather gravel road northeast from Mayo to Elsa (45 km); a total distance of 452 km.

The property lies along the broad South McQuesten River valley on three prominent hills to the south of the valley: on and around Galena Hill, Keno Hill, and Sourdough Hill, collectively known as the Keno Hill District. The Birmingham deposit is located on Galena Hill (Figure 3-2). The Lucky Queen and Onek deposits are located on Keno Hill, while the Bellekeno deposit is located on Sourdough Hill. The Flame and Moth deposit and the Keno Hill District Mill are located at the headwaters of Christal Creek.

Hecla has exploration, maintenance, and camp facilities near the location of the historic mining town of Elsa, which is located just off the Silver Trail Highway, and administration, mill, and mine facilities at the mill complex located near Keno City. The Keno Hill Mine is supplied with electrical power by Yukon Energy Corporation from two hydroelectric plants near Mayo as well as an interconnection to the larger Whitehorse hydropower generating facility. The project area is covered by NTS map sheets 105M/13 and 105M/14.

3.2 MINERAL TENURE, AGREEMENT, AND ROYALTIES

Mineral exploration in the Keno Hill area was initially permitted under the terms and conditions set out by the Government of Yukon (Yukon Government) in the Class 3 Quartz Mining Land Use Permit LQ-00186, issued on July 5, 2006, and valid until July 4, 2011. The former owner, Alexco, subsequently obtained a Class 4 Quartz Mining Land Use Permit – LQ-00240 on June 17, 2008. The two permits were amalgamated on December 8, 2008, under LQ-00240, which has subsequently been renewed as Class 4 Mining Land Use Approval LQ00476 on June 17, 2018.

All quartz mining leases, and Crown Grants have been legally surveyed; the quartz mining claims have not been legally surveyed. The Keno Hill Silver Property quartz mining claims and quartz mining leases are held by one of two wholly owned subsidiaries of Alexco Resource Corp. (doing business as Hecla Yukon): Elsa Reclamation & Development Company Ltd. (ERDC) or Alexco Keno Hill Mining Company Ltd. (AKHM), except for holding a 50% share with third party individuals in three leases (Rico, Kiddo, and Argentum).

The total Hecla Keno Hill property quartz mineral holdings as of December 31, 2023, excluding the mineral claims that are the subject of the separate technical report titled Mineral Resource Estimation Elsa Tailings Project Yukon, Canada, by SRK dated June 16, 2010, covers an area of 238.12 km² and comprises 717 quartz mining leases, 867 quartz mining claims and two Crown Grants as shown in Figure 3-3 (also attached separately with claim label detail in Appendix A).

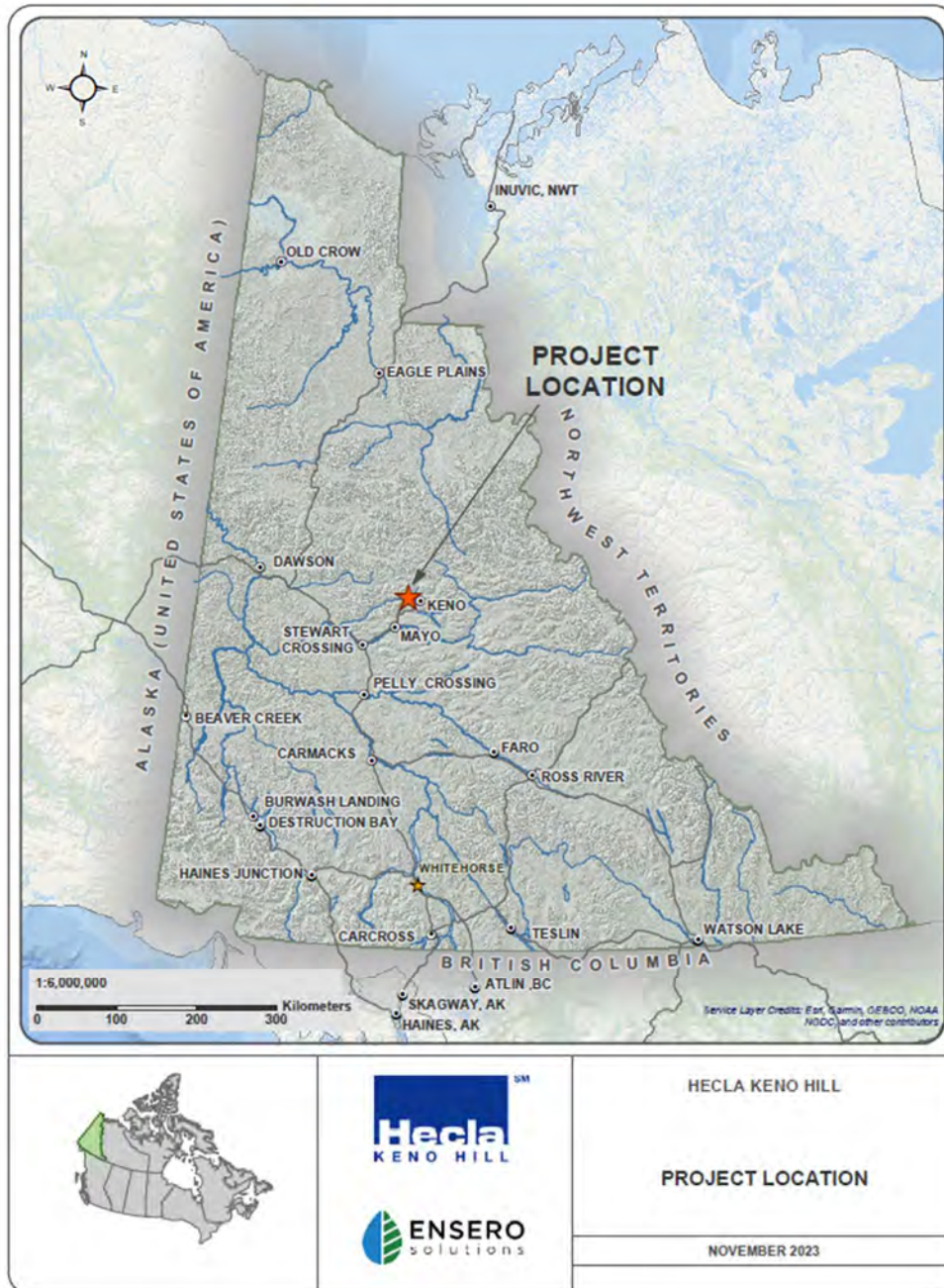

Figure 3-1 Keno Hill Mining Operations Location Map.

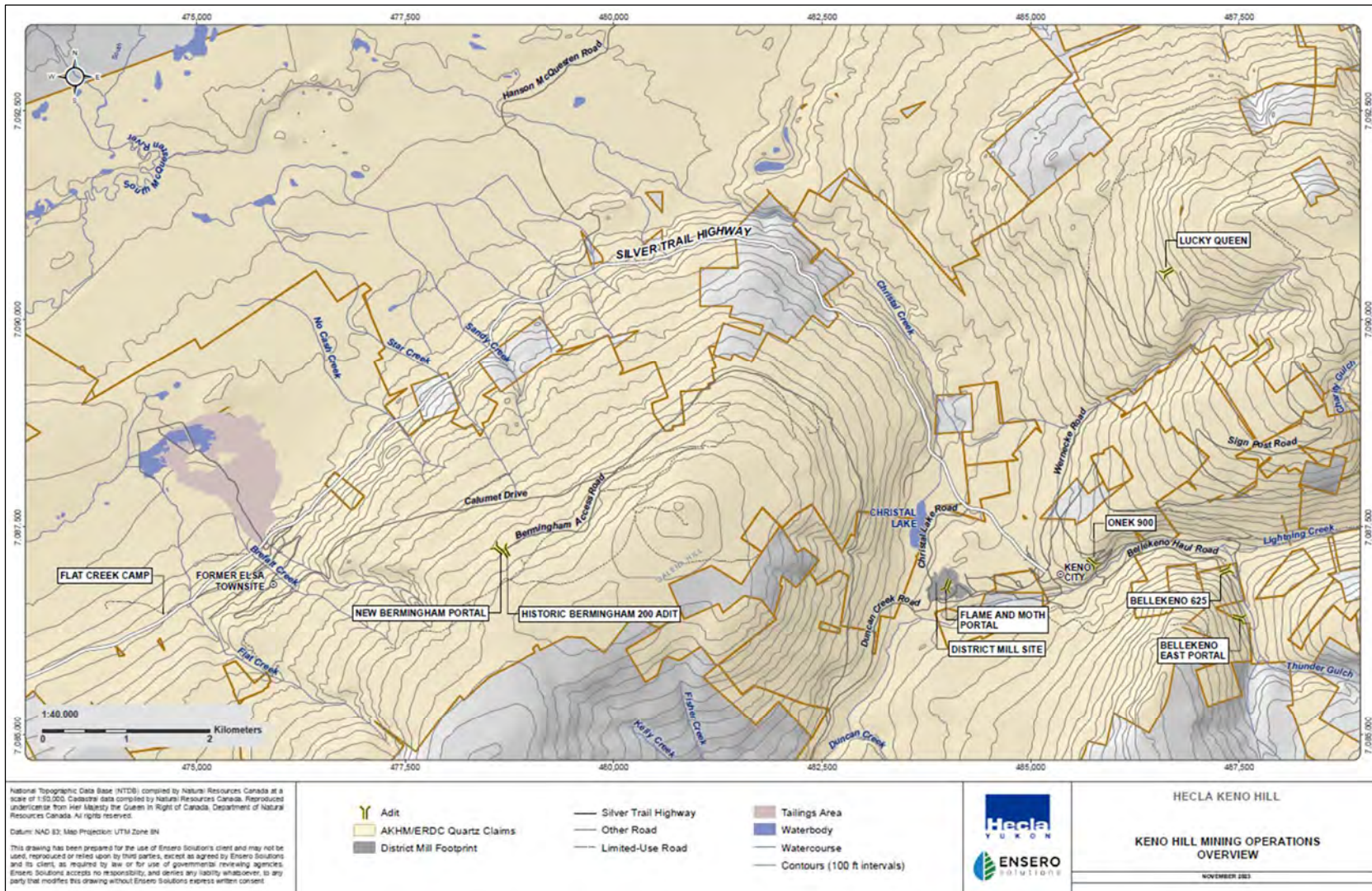

Figure 3-2 Keno Hill Mining Operations Overview.

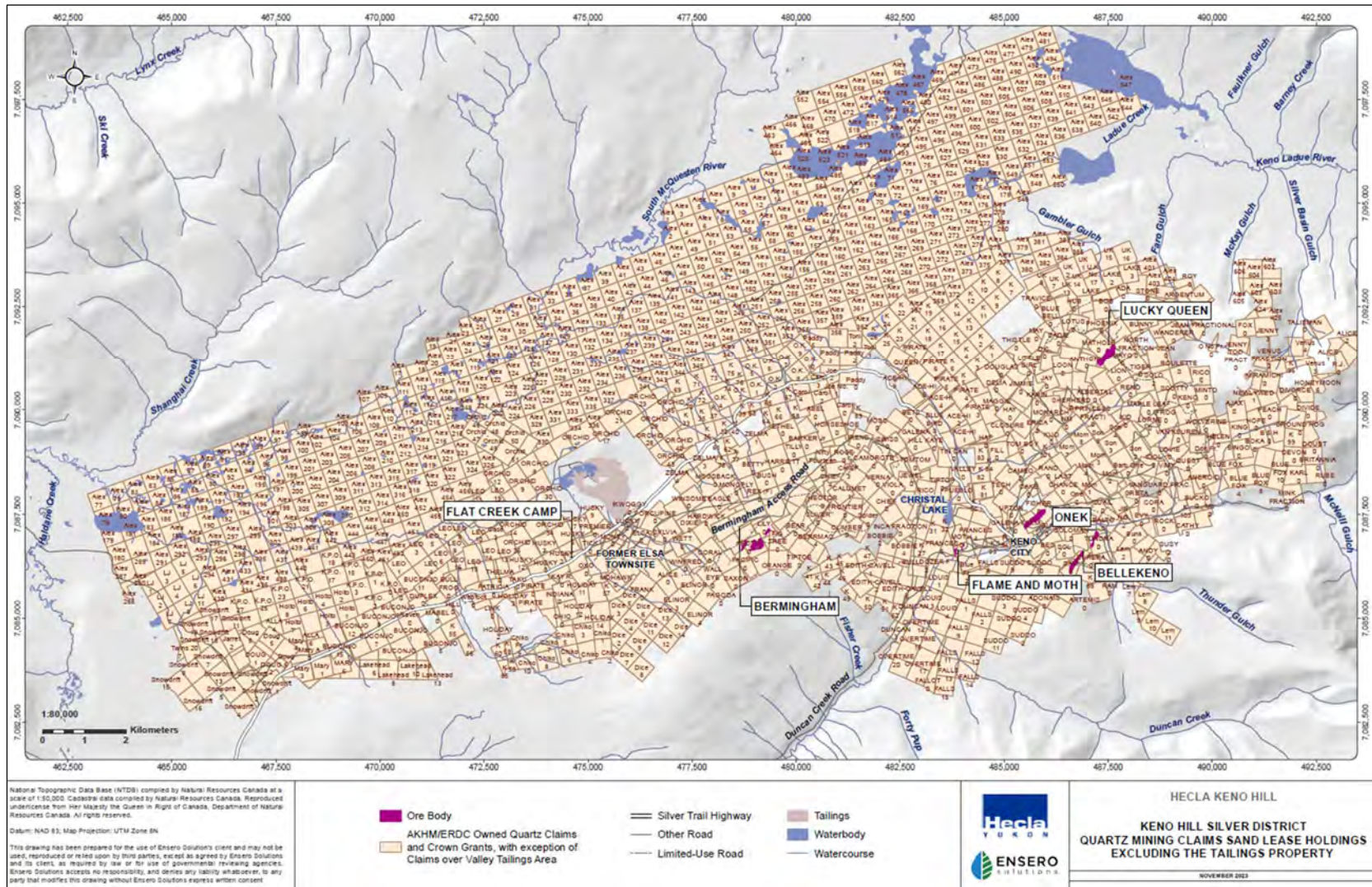

Figure 3-3 – AKHM/ERDC Quartz Mining Claim and Lease Holdings in the Keno Hill Excluding the Elsa Tailings Property.

The Bellekeno deposit is centered at Latitude 63.90853 degrees north; Longitude 135.26201 degrees west. The Mineral Resources for the Bellekeno deposit reported herein are located on the following quartz mining leases: SAM 55327, TUNDRA 12838, WHIPSAW 14081, and NOD FR. 16170.

The Lucky Queen deposit is centered at Latitude 63.94786 degrees north; Longitude 135.25421 degrees west. The Mineral Resources for the Lucky Queen deposit are located on the following quartz mining leases: ANTHONY 12909, OK FRACTION 13094, UNCLE SAM 12923, MATHOLE 12937, and MAYO 12919.

The Flame and Moth deposit is centered at Latitude 63.90588 degrees north; Longitude 135.32931 degrees west. The Mineral Resources for the Flame and Moth deposit are located on the MOTH, FLAME, FRANCES 5, FRANCES 7, and BLUE quartz mining leases.

The Onek deposit is centered at Latitude 63.91293 degrees north; Longitude 135.29134 degrees west. The Mineral Resources for the Onek deposit are located on the following quartz mining leases: FISHER, ELI, GALENA FARM, and LONE STAR.

The Bermingham deposit is centered at Latitude 63.908 degrees north; Longitude 135.424 degrees west. The Mineral Resources for the Bermingham prospect reported herein are located on the ATLANTIC, ARCTIC, ETTA, MASTIFF, LILY, DARWIN, HUXLEY, JUMBO, GIBRALTAR, FIG TREE quartz mining leases.

3.3 MINERAL RIGHTS AND PERMITTING

The Bellekeno, Bermingham, and Flame and Moth mines have all permits and authorizations in place to commence full-scale mine production. However, to maintain full-scale production for an extended period of time, or to increase production at those mines, it is likely that modifications to certain permits will be required, including the Quartz Mining Licence (QML-0009) and the Water Licence QZ18-044, in order to increase water discharge amounts/rates, increase the volume or change location of waste rock and tailings storage or other changes. In addition, the Lucky Queen deposit has in place a Quartz Mining Licence (QML-0009) which authorizes mining operations, but Water Licence QZ18-044 would require an amendment before water-based activities for Lucky Queen can proceed. The key permits for the activities at the Keno Hill Mine are summarized in Table 3-1.

Table 3-1 – Relevant Assessment and Regulatory Approvals.

Purpose	YESAA Approval	Quartz Mining Act Approval	Water Use Licence
Alexco Keno Hill Mining Permits			
Bellekeno Advanced Exploration	Project # 2008-0039 Decision Document	Class 4 Mining Land Use Approval (LQ00476, expires 2028)	Type B Water Use Licence QZ07-078/Amendment 1 QZ10-060, Licence cancelled in 2015 as authorizations moved to amended type A Water Licence in 2015 ²
Birmingham Advanced Exploration	Project#2017-0086 Decision Document	Class 4 Mining Land Use Approval (LQ00476, expires 2028)	Schedule 3 Notice of Water Use/Deposit of Waste without a Licence
Bellekeno Mine Production	Project # 2009-0030 Decision Document	Quartz Mining Licence (QML-0009, amendment 2, expires 2037) ¹	Type A Water Use Licence QZ18-044 issued, Expires 2037 ²
Onek and Lucky Queen Mine Production	Project#2011-0315 Decision Document	Quartz Mining Licence (QML-0009, amendment 2, expires 2037) ¹	No current type A Water Use Licence
Flame and Moth Mine Production	Project # 2013-0161 Decision Document	Quartz Mining Licence (QML-0009, amendment 2, expires 2037) ¹	Type A Water Use Licence QZ18-044 issued, Expires 2037 ²
Birmingham Mine Production	Project#2017-0176 Decision Document	Quartz Mining Licence (QML-0009, amendment 2, expires 2037) ¹	Type A Water Use Licence QZ18-044 issued, Expires 2037 ²
Flat Creek Camp Construction	Project#2006-0157 Decision Document	Class 4 Mining Land Use Approval (LQ00476, expires 2028)	
Exploration	Project#2017-0183 Decision Document	Class 4 Mining Land Use Approval (LQ00476, expires 2028)	
Elsa Reclamation & Development Company Permits			
Care and Maintenance	Project # 2006-0293 and 2012-0141	N/A	Type B Water Use Licence QZ21-012 expires April 18 2043 ²
Reclamation Plan	Project #2011-0187 Decision Document (construction and operation of land treatment facility) Project #2012-0077 Decision Document (building demolition) Project #2018-0169 Decision Document (Reclamation Plan implementation)	N/A	Submitted application QZ21-012 to Water Board following the issuance of YESAB Decision Document for Project #2018-0169

Notes:

- <https://emr-ftp.gov.yk.ca/emrweb/COMM/major-mines/keno-hill/mml-keno-2021-annual-report.pdf>
- <http://www.yukonwaterboard.ca/waterline/>

3.4 AGREEMENTS AND ROYALTIES

Future production from the Project is subject to a 1.5% NSR royalty payable to the Government of Canada. This royalty is a condition of the ARSA. Approximately CAD 1.2 million of the total CAD 4.0 million has been paid or accrued for as of the date of this Report.

Other underlying agreements and contracts are discussed in Section 16.2

3.5 ENVIRONMENTAL LIABILITIES AND OTHER PERMITTING REQUIREMENTS

Under the commercial agreement with the Government of Canada, responsibility for the historic environmental liabilities within Keno Hill is assigned to ERDC, an indirectly wholly owned subsidiary of Hecla, as the tenure holder of Keno Hill. However, under the commercial agreement among ERDC, Alexco, and the Government of Canada, dated July 18, 2013, Canada has agreed to indemnify ERDC in respect of the environmental state of Keno Hill known and unknown as of April 14, 2006. The commercial agreement contains a provision that addresses the liability for the Existing State of the Mine if Hecla brings either historic mines or newly discovered deposits into production or operation.

Under the agreement, ERDC must give notice to Canada for commercial production of ore for commercial purposes. This creates a Production Unit and terminates the indemnity for the Production Area. However, the Indemnity continues to apply to any contamination that may migrate from Keno Hill onto a Production Unit with the exception of contamination from another Production Unit or Advanced Exploration area.

Yukon Government requires financial security from AKHM to cover potential liabilities associated with the cost of reclamation and closure for the Quartz Mining Licence QML-0009. The closure cost estimate is consistent with the plan requirements and closure costing guidance as per the August 2013 Reclamation and Closure Planning for Quartz Mining Projects. AKHM has completed a cost estimate to implement the Revision 7 of the Reclamation and Closure Plan for the Keno Hill Mine and the estimated cost to implement the reclamation and closure plan at the End of Mine Life (EOM) is CAD 9,643,943. Following an internal review process, the amount of security currently required by the Yukon Government for the reclamation and closure of the Keno Hill Mine is CAD 9,681,500 which includes any security already held under the Water Act. AKHM was issued a Type A Water Licence (QZ18-044), and the Yukon Water Board also requires AKHM to furnish and maintain financial security with the Yukon Government which includes any security held under the Quartz Mining Act. Following the review of the Reclamation and Closure Plan Rev 6, pursuant to the Waters Act, AKHM has furnished security of CAD 11,346,433. It is important to note that not all the liabilities included in the cost estimate have yet been realized or created.

Mining Plus is not aware of any other environmental liabilities on the property. The permits and Licenses are discussed in Chapter 17 Environmental Studies, Permitting, and Plans, Negotiations, or Agreements with Local Individuals or Groups.

Hecla has all the required permits to conduct the proposed work on the property and to continue production except for the amendments noted in Section 3.3. Mining Plus is not aware of any other significant factors and risks that may affect access, title, or the right or ability to perform the proposed work program on the property.

3.6 MINERAL AND SURFACE PURCHASE AGREEMENTS

Prior to Hecla’s acquisition of Alexco, United Keno Hill Mines, the previous owner of the properties ceased operations in 1989. In January 2001, the Minister of the Department of Indian Affairs and Northern Development (DIAND) exercised its authority under the Yukon Waters Act by issuing a determination that the mine had been abandoned. In October 2001, the site was declared a Type II Site under the Devolution Transfer Agreement, which meant that the Yukon Government would manage the property, but financial responsibility for environmental liabilities would remain with the Government of Canada.

In June 2005, PricewaterhouseCoopers (PwC), a court-appointed interim receiver and receiver-manager of United Keno Hill Mines Limited and United Keno Hill Minerals Limited (collectively UKHM), selected Alexco as the preferred purchaser of the assets of UKHM. In February 2006, following the negotiation of a Subsidiary Agreement (which subsequently became the ARSA described above) between the Government of Canada, the Government of Yukon, and Alexco, the Supreme Court of Yukon approved the purchase of the assets of UKHM by Alexco through its wholly owned subsidiary ERDC.

The UKHM assets comprised two Crown grants, 674 mining leases, 289 mineral claims, a concentration plant, various buildings, and equipment, as well as partial ownership interest in three mining leases, 36 mineral claims, in addition to a leasehold interest in one mineral claim. Title to all UKHM assets was transferred to Alexco in late November 2007, following the approval of a Type B Water Licence by the Yukon Water Board. In September 2022, Hecla completed the acquisition of Alexco along with its subsidiaries and previously negotiated agreements. All quartz mining leases have been legally surveyed, whereas most of the quartz mining claims have not.

Under the ARSA, ERDC is responsible for ensuring that the site remains in compliance with the terms and conditions of the Water Licence, and all applicable environmental laws. The commercial agreement requires ERDC to develop and implement a Reclamation Plan for Keno Hill, and to retain the liabilities of the UKHM site subject to indemnification by the Government of Canada. Under the commercial agreement, the Government of Canada, as represented by Crown-Indigenous Relations and Northern Affairs Canada (CIRNAC), retains the obligation for funding for the Reclamation Project.

The ARSA also allows Hecla to undertake exploration of the AKHM site and undertake active mining. In the event that Hecla wishes to designate a portion of the AKHM site for development and production (a “Production Unit”), agreements between CIRNAC and ERDC will govern which party is responsible for the costs of reclamation and water-related components of that Production Unit. There is a the Bellekeno Production Unit which covers the affected areas for both Bellekeno and Flame and Moth. Birmingham Production Unit notice was submitted to CIRNAC and approved November 24, 2023.

4. ACCESSIBILITY, CLIMATE, PHYSIOGRAPHY, LOCAL RESOURCES, AND INFRASTRUCTURE

4.1 ACCESSIBILITY

The Project is located in central Yukon Territory, Canada. The closest sizable town is Mayo, which is located on the Stewart River, approximately 45 km to the southwest of the Project location. Mayo is accessible from Whitehorse via a 460 km all-weather road and is also serviced by the Mayo airport, which is located just to the north of Mayo. An all-weather gravel road known as the Silver Trail Highway leads from Mayo to the Project, the historic company town of Elsa, and the village of Keno City

4.2 TOPOGRAPHY, ELEVATION, VEGETATION AND CLIMATE

The Property area is characterized by rolling hills and mountains with a relief of up to 1,600 meters (m). The highest elevation is Keno Hill at 1,975 m. Slopes are gentle except for the north slopes of Keno Hill and Sourdough Hill. The mining properties in the Keno Hill District are located between 850 m and 1,540 m elevation.

The Property is located in the North Yukon Plateau ecoregion, which is a climatic and biophysical subset of the Boreal Cordillera ecozone. Snowfall is minimal during the long cold winters with a mean temperature of -20°C, and extreme lows down to -50°C. Winter days are short with the sun low on the horizon such that north-facing slopes can experience 10 weeks without direct sunlight throughout the winter solstice. The summers are usually dry and warm with maximum temperatures reaching 32°C. Exploration and mining work can be carried out year-round. The growing season is short, but vigorous because of the extended daylight hours in the summer. The average annual precipitation ranges from 300 mm in the valleys to 600 mm on mountaintops. The maximum precipitation is in August and minimum precipitation occurs in April. The Property area is within the Extensive Discontinuous Permafrost Zone. Permafrost is commonly encountered under thick organic layers that cover the South McQuesten River valley and north-facing slopes. Since soil is limited, only low-growing plants exist at higher elevations such as sedges, grasses, and creeping shrubs. Sub-alpine firs and larger shrubs become more dominant in the subalpine and upper boreal zones. The primary tree species along the mid and lower slopes are white spruce (*Picea glauca*), trembling aspen (*Populus tremuloides*), Alaskan birch (*Betula neoalaskana*), and the occasional balsam poplar (*Populus balsamifera*). There is a matrix of scrub birch (*Betula glandulosa*), willow (*Salix* sp.), and ericaceous shrubs with sparse to open black spruce cover. Streams web among the tussocks of sedges and hummocks of moss eventually joining the South MacQuesten River that flows to the Stewart River a tributary of the Yukon watershed.

4.3 PHYSIOGRAPHY

The landscape in this area was formed by past glacial activity, large deposits of glaciofluvial and glaciolacustrine material blanket the valley floor. Morainal till covers the lower to mid-mountain slopes, but only a thin veneer of soil remains in the alpine, here often bedrock and talus are exposed.

4.4 LOCAL INFRASTRUCTURE AND RESOURCES

The Keno Hill Mine is well connected by a network of public and private gravel roads including the Silver Trail Highway and the Bellekeno haul road, which was built to bypass the mining traffic around the village of Keno City. A large number of roads constructed for past mining operations are still serviceable. Local resources in terms of manpower, rental equipment, materials, and supplies are limited and in high demand depending on other resource activities.

The existing infrastructure at or near the Property includes:

- A network of public and private roads connecting the mines, process plants, and other facilities, including the Silver Trail Highway.
- Administration, maintenance, and camp facilities near the town of Elsa.
- Mine workings and infrastructure including water treatment at the Bellekeno deposit.
- Mine workings and infrastructure at both Flame and Moth and Bermingham deposits.
- Mine workings and minor surface buildings at Lucky Queen deposit.
- Waste rock storage facilities at the Flame and Moth, Lucky Queen, Bellekeno, and Bermingham deposits.
- Crushing plant and flotation processing plant.
- Dry stack tailings facility located adjacent to the process plant.
- Process and potable water sources.
- Hydro electrical grid power is available in the area from the Yukon Electrical Company Limited grid. Diesel power backup onsite.
- Airstrip located in the village of Mayo, YT.

5. HISTORY

The history of the Keno Hill mining camp is described in Cathro (2006). The information presented in this section draws heavily from that source.

The Keno Hill mining camp area has a rich history of exploration and mining dating back to the beginning of the 1900s. Earliest prospectors had been working the area in the vicinity of Mayo for gold, especially after the Klondike gold rush of 1898. The first silver was found in 1903; however, interest was low due to the prospector's interest in gold alone — despite an assay from 1905 yielding more than 11 kg/t of silver. Small-scale mining finally commenced in 1913 at the Silver King mine with the first shipment of 50 tonnes of vein material to a smelter in San Francisco, CA.

In the ensuing 100 years of mining, activity peaked and decreased with changes in silver prices, world events, and operating companies in the Yukon. Notable periods of interest in the historic evolution of the Keno Hill mining camp included:

- After WWI, success at the Keno mine led to a staking rush, resulting in the discovery of a number of rich deposits. In the early 1920s, the Treadwell Yukon Company Limited (TYC) acquired a number of claims and started mining.
- After WWII there was a sharp decline in activity in the Keno Hill camp until a new company, Keno Hill Mining Company Ltd., later United Keno Hill Mines Ltd. (UKHM), purchased all TYC properties, started production and sparked increased exploration activity.
- Peak mining activity occurred in the 1950s through to the 1970s, with new discoveries across the district adding to mineral inventory.
- UKHM restarted the TYC mill in April 1947 processing ore primarily from Hector Calumet mine and Elsa mine. Production from the Hector Calumet mine increased in the 1950s and it was the primary silver producer in the region. Overall, Hector Calumet produced 96 million ounces of silver over its mine life.
- Open pit mining began in the late 1970s, mainly to recover selected crown pillars; from 1982 to 1985 Sadie-Ladue and Shamrock were mined on a small-scale basis, and from 1989 to 1990 Shamrock, Silver King, Hector-Calumet, Lucky Queen, Bermingham, and Keno were mined.
- UKHM stopped production from the Keno Hill Silver District permanently in early 1989.
- Between 1990 and 1998 Dominion Mineral Resources and Sterling Frontier Properties Company of Canada Limited (Dominion) carried out both reclamation work across the district as well as exploration at the Bellekeno, Husky Southwest, and Silver King mines in order to reopen the camp.
- In the late 1990s, Dominion abandoned its UKHM right driving UKHM into bankruptcy.
- In 2001, the site was declared abandoned by the Government Operations Centre, and the federal government inherited the assets.
- In June 2005, Alexco was selected as the preferred purchaser of the assets of UKHM by PwC, the court-appointed interim receiver and receiver-manager of the Project holdings. In February 2006, the Supreme Court of the Yukon approved Alexco's purchase of UKHM's assets through Alexco's wholly owned subsidiary ERDC.

- Between 2010 and 2013, Alexco, operating at approximately 200 tpd produced 5.64 million ounces of silver before suspending mining operations.
- In Q4 of 2020 Alexco returned to operation and produced approximately 0.57 million ounces of silver between 2020 and 2022.
- On September 7, 2022, Hecla completed the acquisition of Alexco.

The production history for the District has been documented in Cathro (2006) and reproduced in Table 5-1. Note that the original reference is presented in imperial units and reproduced as such in the table.

Table 5-1 – District Production through to 1989 (Cathro, 2006).

Mine	Tons ('000)	Recovered Grades			Ag ('000 oz)	Pb ('000 lb)	Zn ('000 lb)
		Ag (oz/ ton)	Pb (%)	Zn (%)			
Hector-Calumet	2,721.30	35.4	7.5	6.1	96,220	406,913	334,571
Elsa	491	61.4	4.9	1.4	30,158	47,708	13,485
Husky	429.4	41.7	3.9	0.4	17,889	33,290	3,309
Sadie Ladue	244.3	52.1	6.5	4.5	12,726	31,924	22,029
Keno	283.8	44.4	10.7	3.7	12,602	60,549	21,189
Lucky Queen	123.6	89.2	7.0	2.7	11,019	17,223	6,653
Silver King	207.6	53	7.7	0.8	10,996	31,918	3,510
No Cash	166.5	29.8	3.6	1.9	4,969	11,912	6,188
Galkeno	167.1	27.2	5.2	2.7	4,544	17,437	8,999
Birmingham	186.3	20.3	4.2	0.6	3,778	15,576	2,158
Bellekeno	40.5	42.6	9.8	2.3	1,724	7,967	1,829
Black Cap	48.6	27.4	1.6	0.3	1,331	1,560	269
Onek	95.3	13.6	5.5	3.4	1,299	10,456	6,452
Ruby	40.7	25.2	3	1.3	1,024	2,421	1,023
Shamrock	5.3	180.3	37.6	0.3	962	4,013	37
Comstock	22.9	39.7	10.7	3.8	907	4,891	1,719
Dixie	23.9	20.2	3.8	5.1	482	1,813	2,456
Husky Southwest	10.5	39.6	0.3	0.1	414	56	17
Townsite	18.6	16.4	4.3	2	305	1,583	730
Mt. Keno	1.6	139.3	17.7	-	221	562	-
Miller (UN & Dragon)	9.4	15.1	2.2	0.7	141	420	140
Flame and Moth	1.6	18.3	1.1	0.9	29	35	29

5.1 HISTORY, DRILLING, AND PAST PRODUCTION OF THE BELLEKENO DEPOSIT

The Bellekeno area hosts ten veins on the north-facing slope of Sourdough Hill across the Lightning Creek valley from the Keno mine. Initially staked in 1919 by Andrew Johnson following the discovery of the Tundra vein, the nearby Ram vein was staked the following year. In 1921, Alex Gordon staked the Eureka,

Whipsaw, and Extension mining claims. Combined, these five claim groups covered all the known veins in the Bellekeno deposit.

The Bellekeno deposit was mined during four periods between 1921 and 2011. Each period of mining was followed by a period of extensive exploration to replace exhausted mineral inventory. Between 1921 and 1928, 495 t of hand-sorted vein material grading 9,621 g/t silver was sacked and shipped to San Francisco, CA.

The Depression, World War II, and perhaps some litigation marked the transition into larger-scale mining. In 1947, the claims were purchased by Mayo Mines Ltd. After extensive exploration and adit development, production was briefly recommenced. Under the ownership of Mayo Mines, the Bellekeno mine extracted two products: a direct shipping high-grade product, and a lower-grade concentrate that was processed at the nearby Mackeno mill. With high development requirements, small deposits, and poor milling recovery (<70%), the company operated at a net loss between 1947 and 1954.

Between 1955 and 1965, the property changed owners a number of times, as production attempts proved unsuccessful before it was purchased by UKHM. After acquiring the deposit, UKHM began intermittent exploration, development, and rehabilitation programs, and the development of the Bellekeno 625 adit. Exploration programs included surface overburden drilling, soil and geophysics surveys, trenching, and core drilling. Bellekeno was in production between 1988 and 1989, until UKHM was forced into bankruptcy. Purchased in 2006 by Alexco, the small mineral inventory has been expanded and it was in commercial production from 2011 to 2013, and then between 2020 and 2021. Mining to date by Alexco has extracted 6.2 M oz of silver along with lead, and zinc.

The historic production results for Bellekeno Mine are summarized in Table 5-2.

Table 5-2 — Past Production Records for Bellekeno Property.

Year	Tonnes (t)	Ag (g/t)	Pb (%) ⁴	Ag (oz)
1921-1989 ¹	42,790	1,640	3.7	2,257,200
2010-2013 ¹	242,152	725	9.2	5,644,000
2020-2021	20,170	874	11.9	566,791
Total	305,112	863	8.6	8,467,991

1. Sourced from Alexco, 2021b.

Table 5-3 summarizes the latest Resource and Reserve estimates for the Bellekeno deposit.

Table 5-3 – Historic Resource and Reserve Estimates – Bellekeno (Alexco, 2022a).

Deposit	Class	Tonnes	Ag (g/t)	Au (g/t)	Pb (%)	Zn (%)
Bellekeno	Resource					
	Indicated	213,000	620	n/a	5.5	5.5
	Inferred	302,000	359	n/a	2.5	5.4
	Total	515,000	467	n/a	3.7	5.4
	Reserve					
	Proven	0	0	n/a	0	0
	Probable	12,809	936	n/a	13	7.3
Total	12,809	936	n/a	13.0	7.3	
Bellekeno Surface Stockpile	Reserve					
	Proven	0	0	n/a	0	0
	Probable	3,397	1,150	n/a	21.7	4.5
	Total	3,397	1,150	n/a	21.7	4.5

Notes:

- All Mineral Resources are classified following the CIM Definition Standards for Mineral Resources and Mineral Reserves (May 2014) of NI 43-101.
- Indicated Mineral Resources are inclusive of Probable Mineral Reserves estimates.
- Mineral Resources are not Mineral Reserves and do not have demonstrated economic viability. All numbers have been rounded to reflect the relative accuracy of the estimates.
- Tonnage and grade measurements are in metric units. Contained gold and silver ounces are reported as troy ounces
- Rounding as required by reporting guidelines may result in apparent summation differences between tonnes, grade and contained metal content.
- The Mineral Resource estimate for the Bellekeno deposit is based on an internal Mineral Resource estimate completed by Alexco Resource Corp. and externally audited by SRK Consulting Inc., having an effective date of January 01, 2021. This Mineral Resource estimate has been depleted to reflect all mine production from Bellekeno to the end of December 2020.
- The Mineral Reserves are based on an NSR cut-off value using estimated metallurgical recoveries, assumed metal prices and smelter terms, which include payable factors, treatment charges, penalties, and refining charges.
- Mineral Reserves reported herein are dated May 26, 2021, and do not include depletion since that time.

5.2 HISTORY, DRILLING, AND PAST PRODUCTION OF THE LUCKY QUEEN DEPOSIT

The Lucky Queen deposit was mined from 1927 to 1932 when mineral inventory was exhausted, producing 112,100 t of vein material at 3,060 g/t Ag from two mineralized shoots. Four levels of underground workings (50, 100, 200, and 300) totaling approximately 1,085 m, were developed, with level development roughly coincident with extensive stoping, resulting in the Lucky Queen production totals listed in Table 5-4. There were no historical Mineral Resources or Mineral Reserves remaining at the Lucky Queen mine.

Table 5-4 – Past Production Records for the Lucky Queen Property (Alexco, 2021b).

Mine	Tonnes	Ag (g/t)	Pb (%)	Zn (%)	Ag ('000 oz)	Pb ('000 lb)	Zn ('000 lb)
Lucky Queen	112,100	3,060	7	2.7	11,020	17,220	6,650

The Lucky Queen vein and strike extensions were explored intermittently by surface overburden drilling, trenching, and soil sampling throughout the decades from 1950 to the early 1980s.

A 500-level exploration drift collared near the Black Cap prospect, totaling approximately 1,800 m, was developed by UKHM in 1985-1987. It was designed to come in underneath the historical Lucky Queen workings and to drive a raise up to the 300 level and connect with the No 2 inclined shaft. Poor ground conditions near the shaft, combined with difficulty in locating the vein and an urgent need for miners elsewhere in the Keno Hill caused the adit to be abandoned.

Drilling by Alexco in the Lucky Queen prospect area totaled four surface core drill holes (875 m) in 2006, three surface core drill holes (557 m) in 2007, 12 surface core drill holes (2,999 m) in 2008, 14 surface core drill holes (3,048 m) in 2009, and 14 surface core drill holes (3,625 m) in 2010.

Following the rehabilitation of most of the 500 level, four underground core holes (210 m) were drilled in 2012 outside of the resource area.

Table 5-7 summarizes the most recent Resource and Reserve estimates for the Lucky Queen deposit.

Table 5-5 – Historic Resource and Reserve Estimates – Lucky Queen (Alexco, 2022a).

Deposit	Class	Tonnes	Ag (g/t)	Au (g/t)	Pb (%)	Zn (%)
Lucky Queen	Resource					
	Indicated	132,300	1,167	0.2	2.4	1.6
	Inferred	257,900	473	0.1	1	0.8
	Total	390,200	708	0.1	1.5	1.1
	Reserve					
	Proven	0	0	0	0	0
	Probable	70,648	1,269	0.13	2.71	1.56
	Total	70,648	1,269	0.1	2.7	1.6

Notes:

1. All Mineral Resources are classified following the CIM Definition Standards for Mineral Resources and Mineral Reserves (May 2014) of NI 43-101.
2. Indicated Mineral Resources are inclusive of Probable Mineral Reserves estimates.
3. Mineral Resources are not Mineral Reserves and do not have demonstrated economic viability. All numbers have been rounded to reflect the relative accuracy of the estimates.
4. Tonnage and grade measurements are in metric units. Contained gold and silver ounces are reported as troy ounces
5. Rounding as required by reporting guidelines may result in apparent summation differences between tonnes, grade and contained metal content.
6. The Mineral Resource estimate for the Lucky Queen deposits has an effective date of January 3, 2017.
7. The Mineral Reserves are based on an NSR cu-toff value using estimated metallurgical recoveries, assumed metal prices and smelter terms, which include payable factors, treatment charges, penalties, and refining charges.
8. The Lucky Queen deposit is supported by disclosure in the news release dated May 26, 2021, titled "Alexco Announces 22% Increase to Silver Reserves; Updated Technical Report Demonstrates Robust Economics at Keno Hill".

5.3 HISTORY, DRILLING, AND PAST PRODUCTION OF THE FLAME AND MOTH DEPOSIT

Claim staking and prospecting began at Flame and Moth in 1920. By 1923, numerous surface workings and a 13 m inclined shaft had been sunk with a 4.6 m crosscut developed from it on the Moth claim. An adit was developed to a length of 12.2 m on the Frances 7 claim. Production for this period is not known.

After this early work, little or nothing appears to have happened on the property until the acquisition by UKHM. A 27.4 m inclined shaft was sunk to a vertical depth of 21.3 m along the footwall of what was likely the Moth vein. A crosscut, through the zone 13.7 m below the surface and 42.7 m of drifting 22.9 m below the surface, identified quartz-carbonate vein-hosted mineralization averaging 343 g/t Ag, 1.6% Pb, and 5% Zn developed in quartzite and greenstone along a zone approximately 30.5 m long and up to 9.1 m wide. Thirteen horizontal core drill holes totaling 193 m were drilled from the drift, but the core recovery was poor.

During 1954 and 1955, mineralization of pyrite and minor arsenopyrite was reported up to 240 m along strike to the north. This was explored by bulldozer trenching, soil sampling, and ground geophysics, but was unsuccessful because of the depth of gravel overburden, reported to a 12 m depth.

UKHM returned to Flame and Moth in 1961 with a program of soil sampling and ground geophysics and drilled five surface core drill holes located near the shaft to test the mineralization at depth. The soil samples and geophysics yielded little information, and no veining was intercepted in the drilling.

In 1965, 28 vertical overburden drill holes were drilled, along with another attempt at soil sampling and geophysics. A proposal to excavate an open pit was first made on this date, based on a calculated resource of 3,360 t grading 573 g/t Ag, 1.4% Pb, and 5.6% Zn. The pit would have reached 18.3 m below the surface.

In 1974, four lines of angled overburden drill holes totaling 989 m were drilled for extensions along a 180 m strike length with limited success due to deep overburden and broken ground conditions, although a weakly mineralized structure was located at 76 m in the footwall of the main vein.

More overburden drilling was completed along strike in 1984 and four core drill holes were sited to test the downward projection of the known mineralization. The deeper drilling (60 to 90 m below the surface) returned only very low values from a wide but diffuse pyritic vein zone. A small amount of vein material (368 t grading 699 g/t Ag, 1.39% Pb, and 0.72% Zn) was sent to the mill, which may have come from vein material exposed during stripping of overburden in preparation for the open pit development. In May 1987, the open pit Mineral Resources were re-evaluated at 12,600 t grading 699 g/t Ag and 4.0% Pb to a depth of 24.4 m. The key assumptions used to estimate this historical estimate are not known. That estimate is superseded by the Mineral Resources reported herein.

Total production at the Flame and Moth property is listed in Table 5-6 as 1,440 t grading 627 g/t Ag, 1.1% Pb, and 0.9% Zn. It is assumed most of these figures came from the underground work in the 1950s.

Historic production and production during Alexco operations are combined in Table 5-6.

Table 5-6 – Past Production Records for the Flame and Moth Property.

Mine	Year	Tonnes	Ag (g/t)	Pb (%)	Zn (%)	Ag (oz)	Pb (lb)	Zn (lb)
Flame and Moth	1950s*	1,440	627	1.1	0.9	29,100	35,400	28,900
	2022	8,563	496	1.5	5.4	136,686	275,603	1,021,533
	2023	16,285	621	1.8	5.6	324,984	640,218	2,025,712
	Total	26,288	581	1.6	5.3	490,771	951,221	3,076,145

*Cathro, 2006.

Surface core drilling was performed by the previous owner, Alexco, in the Flame and Moth resource area and totaled 14 drill holes (3,986.2 m) in 2010, 32 drill holes (7,149.2 m) in 2011, and 48 drill holes (10,106.5 m) in 2012, eight drill holes (1,835 m) in 2013, 53 drill holes (13,360 m) in 2014, six drill holes (781 m) in 2021, and 8 holes (879 m) in 2022.

Underground drilling resumed later in the 2022 year under Hecla management completing a further 11 holes for 1,059 meters. No additional drilling was conducted at Flame and Moth in 2023.

Table 5-7 summarizes the most recent Resource and Reserve estimates for the Flame and Moth deposit.

Table 5-7 – Historic Resource and Reserve Estimates – Flame and Moth (Alexco, 2022a).

Deposit	Class	Tonnes	Ag (g/t)	Au (g/t)	Pb (%)	Zn (%)
Flame and Moth	Resource					
	Indicated	1,679,000	498	0.4	1.9	5.3
	Inferred	365,200	356	0.3	0.5	4.3
	Total	2,044,200	473	0.4	1.6	5.1
	Reserve					
	Proven	0	0	0	0	0
	Probable	721,322	672	0.5	2.7	6.2
	Total	721,322	672	0.5	2.7	6.2

Notes:

- All Mineral Resources are classified following the CIM Definition Standards for Mineral Resources and Mineral Reserves (May 2014) of NI 43-101.
- Indicated Mineral Resources are inclusive of Probable Mineral Reserves estimates.
- Mineral Resources are not Mineral Reserves and do not have demonstrated economic viability. All numbers have been rounded to reflect the relative accuracy of the estimates.
- Tonnage and grade measurements are in metric units. Contained gold and silver ounces are reported as troy ounces
- Rounding as required by reporting guidelines may result in apparent summation differences between tonnes, grade and contained metal content.
- The Mineral Resource estimate for the Flame and Moth deposit has an effective date of January 3, 2017.
- The Mineral Reserves are based on an NSR cut-off value using estimated metallurgical recoveries, assumed metal prices and smelter terms, which include payable factors, treatment charges, penalties, and refining charges.
- The Flame and Moth deposit is supported by disclosure in the news release dated May 26, 2021, titled "Alexco Announces 22% Increase to Silver Reserves; Updated Technical Report Demonstrates Robust Economics at Keno Hill".

5.4 HISTORY, DRILLING, AND PAST PRODUCTION OF THE ONEK DEPOSIT

The Onek Mining Company Ltd. was organized in 1922 to explore the core Onek claims via a number of open cuts and shallow underground workings in two shafts. From 1950 to 1952, UKHM reopened the shafts and drove an adit in from the northwest to drift along the vein strike at the 400 level for approximately 396 m, driving raises up into the historic workings along the way. Some developmental mineralized material was removed. The Onek deposit was revisited in the early 1960s with limited success due to manpower shortages and poor ground support, as the timbers from the 1950s had been left in place. All mining at Onek ceased in 1965 until the late 1980s when a 20 m to 40 m deep open pit was developed over the length of the majority of the Onek workings near the historical shafts. Historical production from the Onek deposit is shown in Table 5-8.

Surface exploration consisted of extensive overburden drilling along the vein strike as exploration stepouts and as infill drilling for open pit delineation.

Table 5-8 – Past Production Records for the Onek Property (Alexco, 2021b).

Mine	Tonnes	Ag (g/t)	Pb (%)	Zn (%)	Ag (oz)	Pb (lb)	Zn (lb)
Onek	86,447	466	5.5	3.4	1,299,333	10,456,254	6,452,107

Drilling was performed by the previous owner (Alexco) in the Onek prospect area and totaled 13 surface core drill holes (2,803 m) in 2007, 29 surface core drill holes (5,127 m) in 2008, 25 surface core holes (2,913 m) in 2010, 12 surface core holes (1,138 m) in 2011, and two surface core holes (531.98 m) in 2012.

A 220 m decline was driven towards the Onek deposit in 2012 and 2013 following the drilling of a single 236.77 m surface core portal cover hole. In 2013, 12 underground core holes (738.50 m) were drilled.

Table 5-9 summarizes the most recent Resource for the Onek deposit. There are no Reserves for the Onek deposit.

Table 5-9 – Historic Resource and Reserve Estimates – Onek (Alexco, 2022a).

Deposit	Class	Tonnes	Ag (g/t)	Au (g/t)	Pb (%)	Zn (%)
Onek	Resource					
	Indicated	700,200	191	0.6	1.2	11.9
	Inferred	285,100	118	0.4	1.2	8.3
	Total	985,300	170	0.5	1.2	10.9

Notes:

1. All Mineral Resources are classified following the CIM Definition Standards for Mineral Resources and Mineral Reserves (May 2014) of NI 43-101.
2. Indicated Mineral Resources are inclusive of Probable Mineral Reserves estimates.
3. Mineral Resources are not Mineral Reserves and do not have demonstrated economic viability. All numbers have been rounded to reflect the relative accuracy of the estimates.
4. Tonnage and grade measurements are in metric units. Contained gold and silver ounces are reported as troy ounces
5. Rounding as required by reporting guidelines may result in apparent summation differences between tonnes, grade and contained metal content.
6. The Mineral Resource estimate for the Onek deposit has an effective date of January 3, 2017.

5.5 HISTORY, DRILLING, AND PAST PRODUCTION OF THE BIRMINGHAM DEPOSIT

The first claims in the Birmingham area were staked in 1921, within a decade of commercial production starting in Keno Hill. Shallow underground workings were initiated in 1923 with the discovery of vein float and limited production of high-grade silver and lead from the Birmingham vein ensued. When TYC optioned the Mastiff claim group in 1928, a 30 m shaft and 223 m of drifting had been completed on three separate levels. The underground workings showed a structure with a maximum width of 17 m on the 100 level that contained multiple bands of mineralization with interstitial waste that was cut off at its southwest extent by the Mastiff fault.

The TYC optioned the ground in 1928, completed additional underground workings, and identified a fault offset vein portion but dropped the lease in 1930 due to low silver prices and a lack of ore-grade material. Trenching and prospect shafts identified the offset vein approximately 91 m to the west-northwest, where TYC sank the No. 1 shaft and completed 22 m of drifting. An oxidized siderite-pyrite vein with some galena was located below the position of the future main Birmingham pit but no mineralized material was reported from 127 m of drifting completed on the 200 level. TYC relinquished the lease in 1930 due to low silver prices and the absence of economic-grade material. A variety of individual workers extracted another 676 t grading 7,875 g/t Ag and 70% Pb between 1930 and 1940. This work was poorly documented but is known to include considerable trenching, shafting, and drifting during 1930, 1932 to 1937, and 1939 to 1940.

From 1948 to 1951, UKHM drove an adit and drift approximately 9 m below the bottom of the TYC workings. In 1952, many of the old TYC workings were surveyed and sampled, but the adit level was subsequently abandoned in 1954 after very little ore-grade material was realized. During this time, UKHM reportedly milled 5,165 tons of ore at 47.3 oz/ton (opt) Ag, 8% Pb, and 1.3% Zn, of which all but 60 tons were recovered from the old dumps.

Between 1965 and 1982, 874 overburden drillholes totaling 19,931 m, and 27 core holes totaling 2,407 m were drilled in the Birmingham area, a small portion of which occurred in the present resource area. Poor ground conditions prevented many of these holes from adequately penetrating the vein zone, however, they outlined an open pit resource and stripping began in 1977.

Stripping on the main Birmingham pit began in 1977 and until 1983 there was reportedly produced 82,649 t grading 572 g/t Ag. Overburden drilling and open pit mining led to a much better understanding of geology. The feasibility of deepening the Birmingham pit was evaluated from 1980 to 1982 with several percussion drill holes testing the vein below the pit and two diamond drill holes testing the Bleiler extension to the northeast. The drill holes indicated a narrowing of the vein to 3.0 m to 4.5 m wide and did not encounter an economical grade.

To the southwest of the open pit and in the hanging wall of the Mastiff Fault, several historic shafts had tested the offset extension of the Birmingham Vein. These included the No. 3 shaft, sunk by TYC, which included 22 m of drifting on the 45 level. The vein was reported to be 2.4 m wide and to mainly consist of siderite with small bunches of galena; however, no ore was encountered. A small open pit did operate on this segment of the vein in the mid-1980s, and an intended second pit located 150 m to the southwest was stripped to bedrock in 1983. However, the veins exposed there appeared weak and un-mineralized. The historical mineral resource estimate does not use Mineral Resource categories stipulated by S-K 1300. The historical estimate should not be relied upon; it is only stated here for historical completeness.

The exploration conducted by Alexco was the first comprehensive exploration effort in the District since 1997. The first holes drilled by Alexco in the Birmingham area were in 2009 (two core holes totaling 523 m), targeting the Birmingham Vein at depth in the hanging wall of the Mastiff Fault below an area with a historic shallow open pit resource. The results of this drilling were sufficiently encouraging to continue exploration in 2010 and 2011. Alexco conducted further diamond drilling programs at Birmingham in 2012, 2014, 2015, and 2016 in the Birmingham deposit and surrounding area.

Between 2009 and September 2022, a total of 93,777 m surface core diamond drilling was completed by Alexco at Birmingham, with a total of 169 drill holes, including two drill holes (523 m) in 2009, nine drill holes (3,045 m) in 2010, 25 drill holes (6,888 m) in 2011, 17 drill holes (5,576 m) in 2012, eight drill holes (2,667 m) in 2014, eight drill holes (2,606 m) in 2015, 50 drill holes (17,371 m) in 2016, 38 drill holes (13,277 m) in 2017 and 12 drill holes (4,369 m) in 2018. In addition, 24 underground drill holes (4,214 m) were completed from the exploration decline in 2018. 25 holes (12,965 m) were completed in the Birmingham Northeast Deep zone in 2019 and 2020, 60 holes (18,341 m) in 2021, and 6 holes (730 m) in 2022. All holes were diamond-cored in HQ/HTW apart for a few reduced to NQ/NTW because of ground conditions.

In total, Birmingham reportedly produced 3,777,932 oz of silver from 168,979 tonnes of material milled prior to the 1960's, and 1,568,000 oz of silver from 56,061 tonnes from 2020 through 2023.

Historic production and production during Alexco operations are combined in in Table 5-10.

Table 5-10 Past Production Records for the Bermingham Property.

Mine	Year	Tonnes (t)	Ag (g/t)	Pb (%)	Zn (%)	Ag ('000 oz)	Pb ('000 lb)	Zn ('000 lb)
Bermingham	Before 1960s*	168,979	695	4.2	0.6	3,778	15,575	2,158
	2020-2022	16,307	625	1.5	1.5	328	535	548
	2023	39,754	1,227	3.2	1.2	1,568	2,832	1,031
	Total	225,040	784	3.8	0.8	5,674	18,943	3,736

*Cathro, 2006.

Table 5-11 summarizes the most recent Resource and Reserve estimates for the Bermingham deposit.

Table 5-11 – Historic Resource and Reserve Estimates – Bermingham (Alexco, 2022a).

Deposit	Class	Tonnes	Ag (g/t)	Au (g/t)	Pb (%)	Zn (%)
Bermingham	Resource					
	Indicated	1,562,700	939	0.2	2.6	1.7
	Inferred	843,400	735	0.2	2.0	1.3
	Total	2,406,100	867	0.2	2.4	1.6
	Reserve					
	Proven	0	0	0.0	0.0	0.0
	Probable	630,173	899	2.3	1.3	0.1
	Total	630,173	899	2.3	1.3	0.1

Notes:

- All Mineral Resources are classified following the CIM Definition Standards for Mineral Resources and Mineral Reserves (May 2014) of NI 43-101.
- Indicated Mineral Resources are inclusive of Probable Mineral Reserves estimates.
- Mineral Resources are not Mineral Reserves and do not have demonstrated economic viability. All numbers have been rounded to reflect the relative accuracy of the estimates.
- Tonnage and grade measurements are in metric units. Contained gold and silver ounces are reported as troy ounces
- Rounding as required by reporting guidelines may result in apparent summation differences between tonnes, grade and contained metal content.
- The Mineral Resource estimate for the Bermingham deposit is supported by disclosure in the news release dated January 18, 2022, titled "Alexco Reports 43% Expansion of Bermingham Indicated Resource to 47 Million Ounces of Silver at 939 Grams per Tonne; Remains Open" and the Mineral Resource estimate has an effective date of November 30, 2021.
- The Mineral Reserves are based on an NSR cut-off value using estimated metallurgical recoveries, assumed metal prices and smelter terms, which include payable factors, treatment charges, penalties, and refining charges.
- The Bermingham deposit is supported by disclosure in the news release dated May 26, 2021, titled "Alexco Announces 22% Increase to Silver Reserves; Updated Technical Report Demonstrates Robust Economics at Keno Hill".

6. GEOLOGICAL SETTING, MINERALIZATION, AND DEPOSIT

6.1 REGIONAL GEOLOGY

The Keno Hill (KH) is located within the northwestern part of the Selwyn Basin in the central Yukon. The area is underlain by Upper Proterozoic to Mississippian metasedimentary rocks that were originally deposited in a marine shelf environment along the northern Cordilleran continental margin (Figure 6-1).

A compressional regime that existed during the Jurassic and Cretaceous produced thrusts, folds, and penetrative fabrics of various scales, with the geological structure in the area dominated by the highly deformed northwest trending Robert Service and Tombstone Thrust Sheets. Early large-scale deformation (D1 and D2) produced recumbent folds, resulting in local structural thickening of strata. A third deformational event (D3) produced gentle southwest plunging synform and antiform pairs (Roots, 1997). The dominant structural fabric (foliation) is essentially axial planar to the early recumbent folds.

The Robert Service Thrust Sheet lies immediately to the south of the Keno Hill and is composed of a Late Proterozoic to Cambrian coarse-grained quartz-rich turbidite sequence containing interbedded shales and locally limestone of the Hyland Group Yusezyu Formation.

The Tombstone Thrust Sheet underlies the KH and consists of basal Devonian phyllite, felsic meta-tuffs, and metaclastic rocks of the Earn Group that are conformably overlain by the Mississippian Keno Hill Quartzite Formation. The stratigraphy is locally thickened due to folding and/or thrusting and the basal part of the Keno Hill Quartzite is the predominant host of the silver-lead-zinc mineralization.

Four periods of intrusive rocks are recognized. During the Late Triassic, at about 232 million years ago (Ma), gabbro to diorite formed sills within the Tombstone Thrust Sheet. A second phase of plutonism took place approximately 92 Ma ago in the early Cretaceous and resulted in the widespread and voluminous felsic Tombstone intrusions of granitic to granodioritic composition that are regionally associated with gold mineralization. Cretaceous lamprophyre dated at 89 Ma occurs as meter scale dykes and sills. The youngest intrusions are peraluminous megacrystic potassium feldspar granite of the Upper Cretaceous McQuesten suite dated at approximately 65 Ma.

In addition to the polymetallic silver–lead–zinc mineralization occurring at Keno Hill, the region also hosts other mineral occurrences including showings of tungsten, copper, gold, lead, zinc, antimony, and barite.

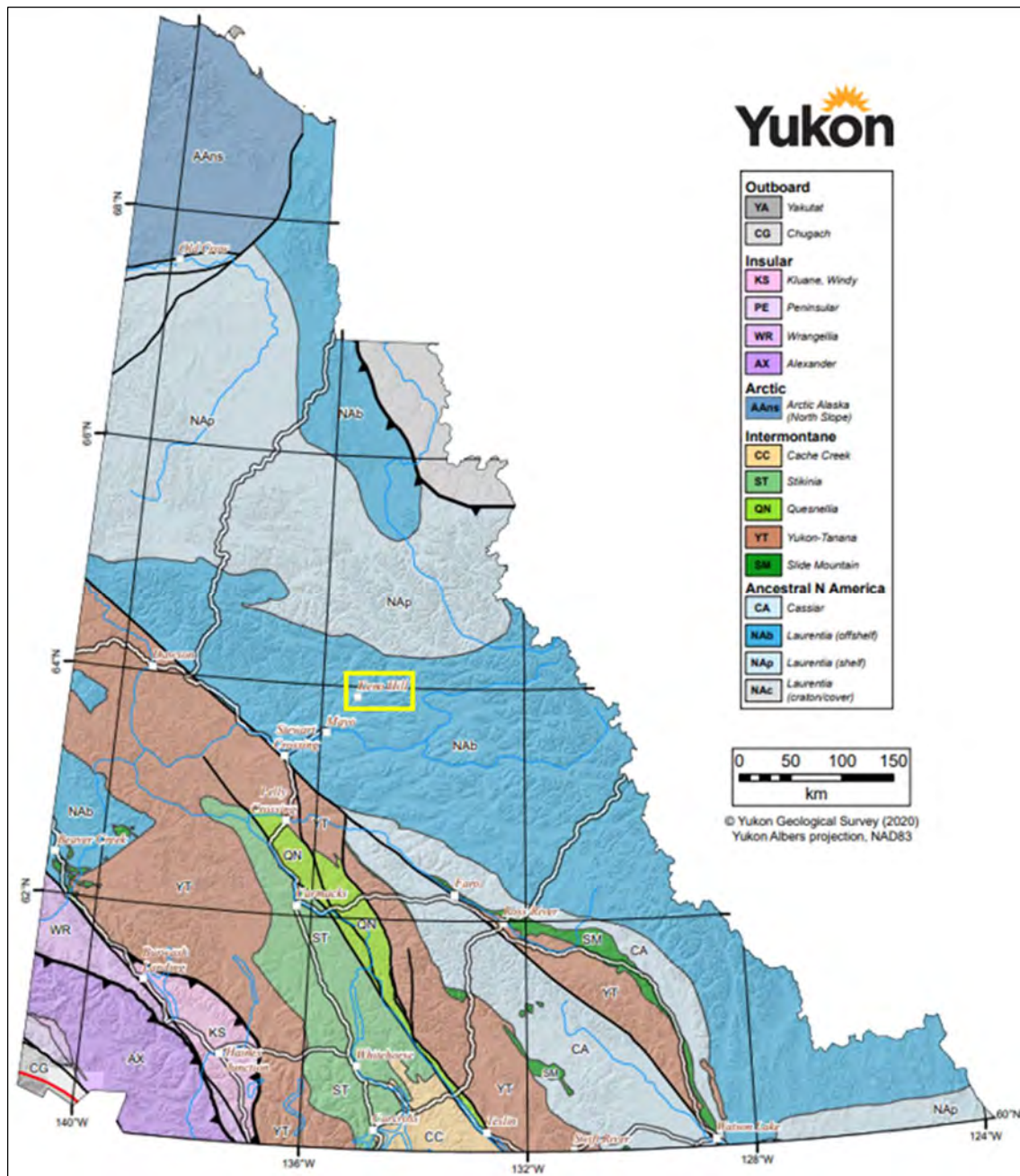

Figure 6-1 – Regional Geology (Yukon Geological Society, 2022).

6.2 LOCAL GEOLOGY

The KH geology is dominated by the Mississippian Keno Hill Quartzite Formation comprising the Basal Quartzite Member and conformably overlying Sourdough Hill Member. The sequence is overthrust from the south by the Upper Proterozoic Hyland Yusezyu Formation and is conformably underlain in the north by the Devonian Earn Group as shown in the simplified local stratigraphic column in Figure 6-2.

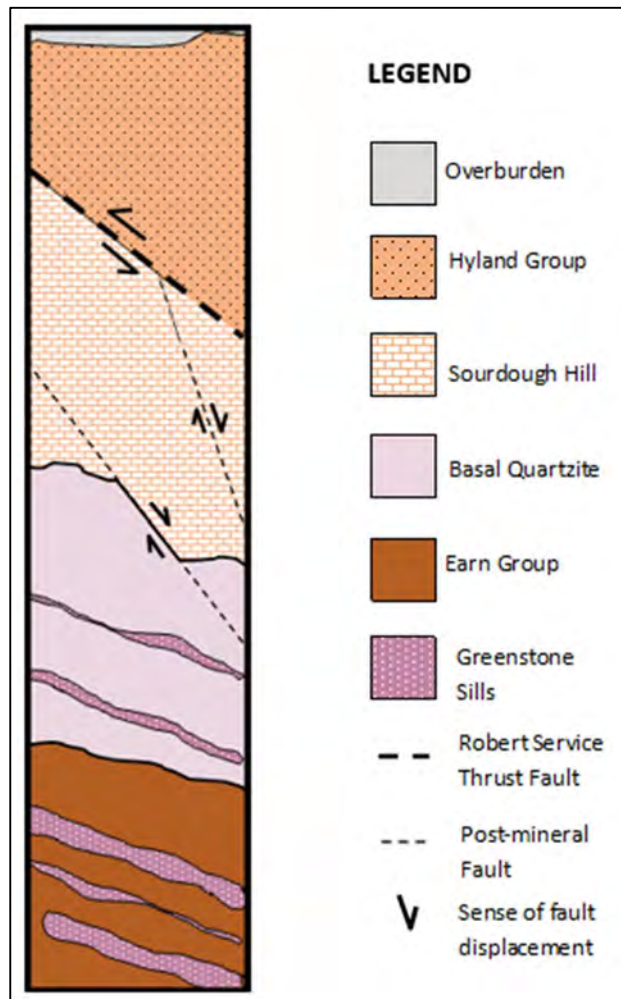

Figure 6-2 – Local Geology Simplified Stratigraphic Column of the Keno Hill.

The Earn Group and Keno Hill Quartzite are locally intruded by stratigraphically conformable, although lensoidal, Middle Triassic greenstone sills, for which any feeder dykes are unrecognizable. The sequence was metamorphosed to greenschist facies assemblages during Cretaceous regional deformation at about 100 Ma and subsequently intruded by aplite sills or dikes considered to be related to the Tombstone intrusive suite.

Illustrated in Figure 6-3 is a local geological cross-section along Line A-A' with an accompanied legend (Figure 6-4), with its location marked on the generalized Property Geology map in Figure 6-5.

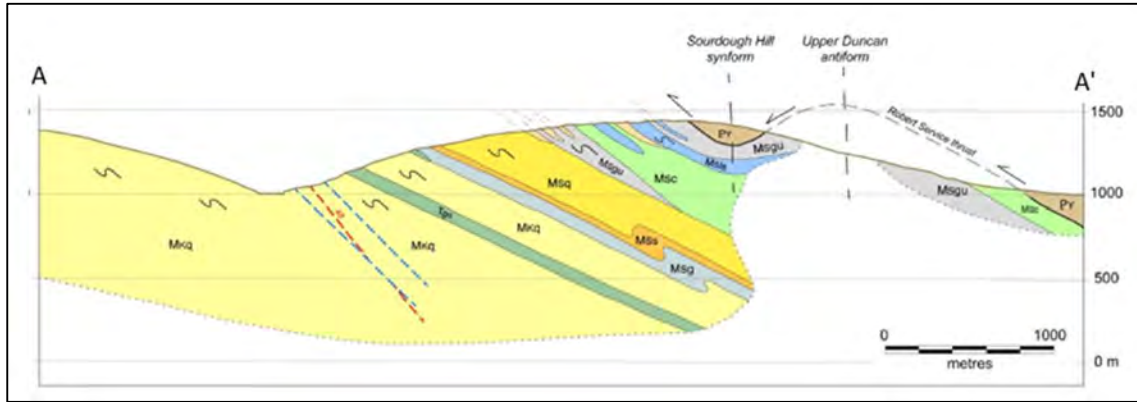

Figure 6-3 – Local Geology Cross-section of the Keno Hill (Yukon Geological Society, 2020).

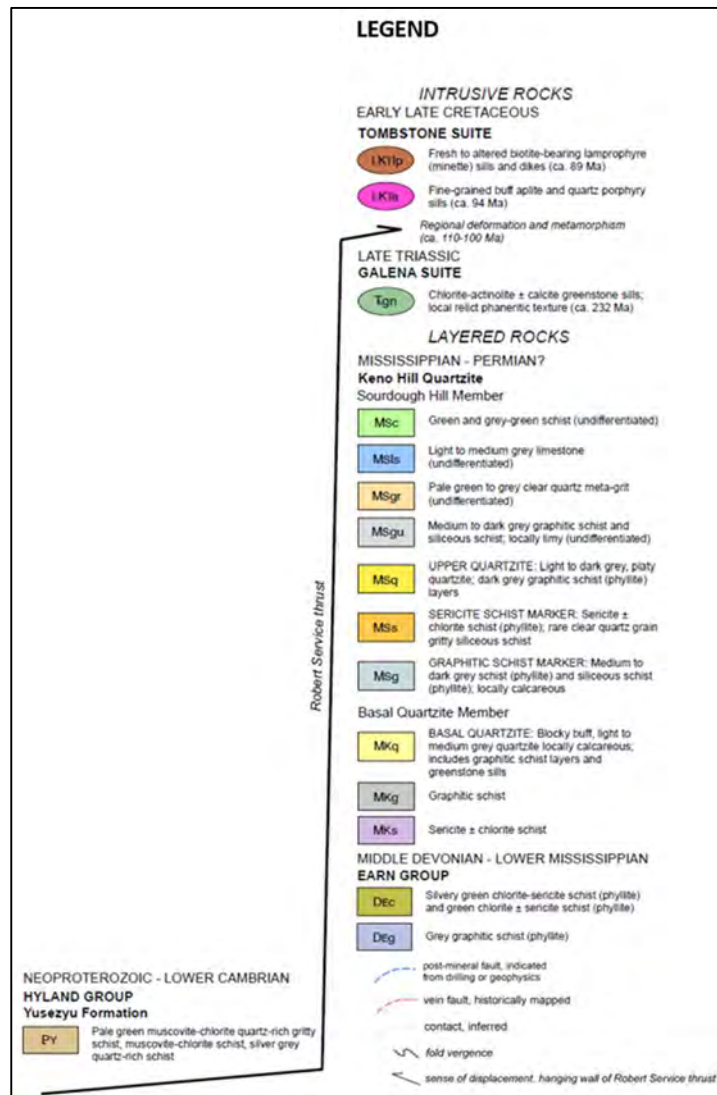

Figure 6-4 – Keno Hill Simplified Stratigraphy Legend (Yukon Geological Survey, 2020).

6.3 PROPERTY GEOLOGY

The Yusezyu Formation of the Precambrian Hyland Group comprises greenish quartz-rich chlorite-muscovite schist with locally clear and blue quartz-grain gritty schist and is separated from the Keno Hill sequence by the regionally extensive Robert Service Thrust Fault that occurs immediately south of the area.

The Earn Group, formerly mapped as the “lower schist formation” (Boyle, 1965) is typically composed of recessive weathering grey graphitic schist and green chlorite-sericite schist with an upper siliceous graphitic schist found locally.

Within the Keno Hill Quartzite Formation, the Basal Quartzite Member that is the dominant host to the silver mineralization comprises commonly calcareous, thick to thin-bedded quartzite and graphitic schist and may be up to approximately 1,100 m thick where structurally thickened. The overlying Sourdough Hill Member, formerly mapped as the “upper schist formation” (Boyle, 1965), is up to approximately 900 m in thickness and comprises predominantly graphitic and sericitic schist, chloritic quartz augen schist some of which may be of volcanogenic origin, and minor thin embedded limestone.

Three phases of folding are identified with the two earliest phases consisting of isoclinal folding with sub-horizontal, east, or west-trending fold axes, the axial plane forming the dominant regional foliation. The later fold phase displays sub-vertical axial planes and moderate southeast-trending and plunging fold axes. The first phases of folding formed structurally dismembered isoclinal folds of which the Basal Quartzite Member outlines synforms at Monument Hill where the Lucky Queen deposit is located and at Caribou Hill, while between Galena Hill and Sourdough Hill the Bellekeno deposit, the Flame and Moth and Birmingham deposits are located on the upper limb of a large-scale anticline that closes to the north.

Up to four main periods of faulting are recognized with the oldest fault set consisting of south-dipping foliation parallel structures that developed contemporaneously with the first phases of folding, sometimes shown as “low angle bedding faults”. The Robert Service Thrust Fault truncates the top of the Keno Hill Quartzite Formation and sets the Precambrian schist of the Yusezyu Formation above the Mississippian Sourdough Hill Member. The silver mineralization in Keno Hill is hosted by a series of northeast-oriented, southeasterly dipping veins formed in pre- and syn-mineral faults referred to as vein-faults (Boyle, 1965) that display left lateral normal oblique displacement. There are two related sets locally recognized as either a more easterly trending “longitudinal” vein set that, depending on the competency of the host rock, can form up to a 30 m wide zone of anastomosing subparallel veins, or a more northerly trending “transverse” vein set that can reach up to 5 m in thickness.

The mineralized vein-faults are commonly offset by northwest striking, steeply southwest dipping, post-mineral cross faults, which display right lateral normal oblique displacement. The simplified geology of Keno Hill and the location of the mineral deposits are shown in Figure 6-5.

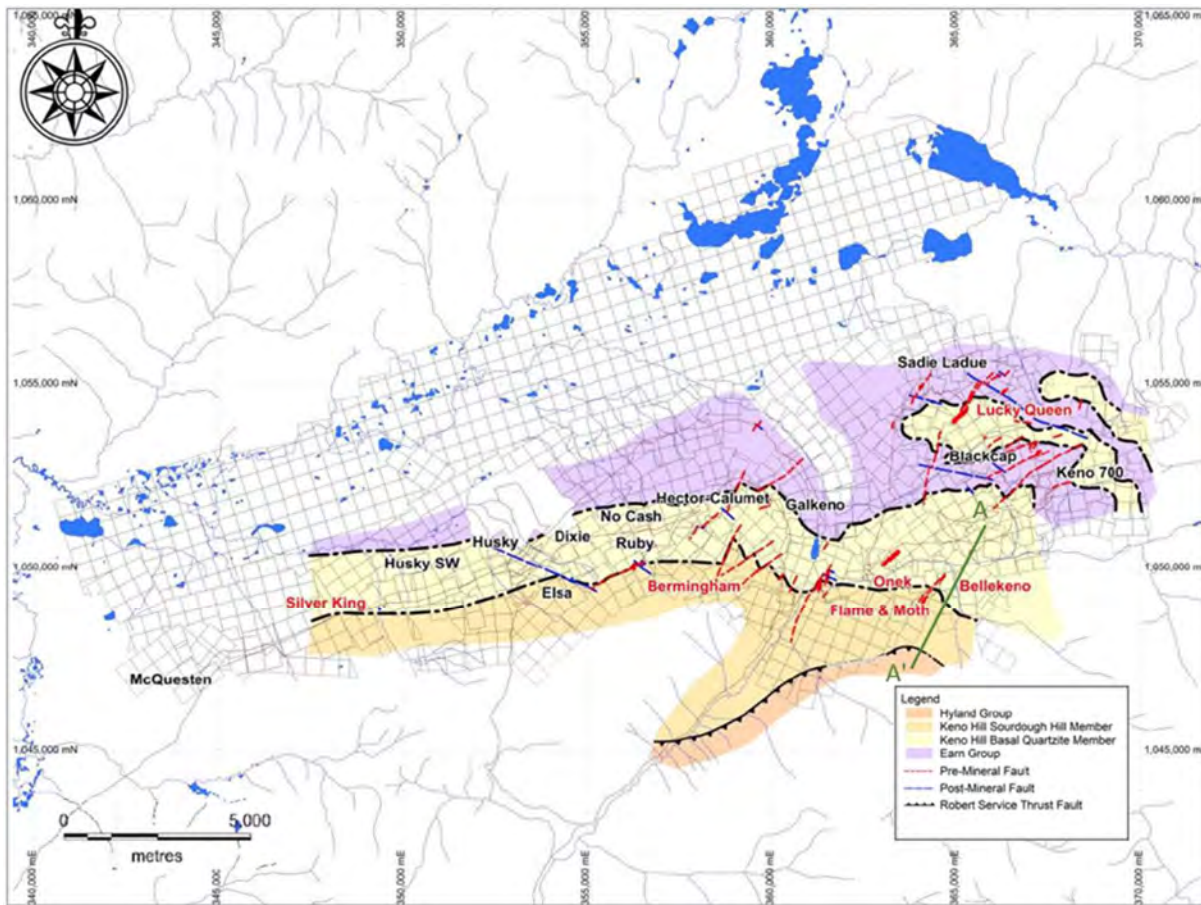

Figure 6-5 – Geology Map of the Keno Hill (RPA, 2017).

6.4 MINERALIZATION

Mineralization in the KH comprises carbonate vein-hosted polymetallic silver-lead-zinc as described by Boyle (1965), Cathro (2006), Murphy (1997), and Roots (1997). Mineralized zones typically exhibit a succession of hydrothermally precipitated minerals deposited in veins or veinlets resulting from multiple pulses of hydrothermal fluid boiling events, probably related to repeated depressurization due to movement along the host fault structures. As a result, a progressive series of differing mineral depositional stages, assemblages, and textures can be identified. To a minor extent, supergene alteration may have further changed the nature of the mineralogy in the veins, although this may have been largely removed due to glacial erosion.

In general, common gangue minerals include (manganiferous) siderite and, to a lesser extent, quartz, and calcite. Silver occurs predominantly in argentiferous galena and argentiferous tetrahedrite (freibergite) with associated native silver, and the silver-bearing sulfosalts polybasite, stephanite, and pyrargyrite are other important silver-bearing minerals. Lead occurs in galena and zinc in sphalerite, which can be either an iron-rich or iron-poor variety. Other sulfides include pyrite, pyrrhotite, arsenopyrite, and chalcopyrite.

Historically, it was believed that economic mineralization in the Keno Hill mining camp was restricted to a shallow zone of approximately 120 m thickness. However, the 370 m depth of production from the Hector-Calumet mine and drill indicated mineralization to over 350 m depth at Flame and Moth and Birmingham demonstrate that silver-rich veins do exist over greater vertical intervals and suggest that other known veins may exhibit exploration potential at depth. It has been suggested (Cathro, 2006) that the mineralization may exhibit a vertical zonation with a typical mineralized shoot displaying a high silver and lead-rich top down to a low silver-zinc-rich base; however, this has not been verified.

Across the District, favorable environments for mineralization are considered to occur where:

- Competent quartzite or greenstone host rock is present on one wall of the vein fault as it can be observed that veins pinch down significantly in schist-bound structures.
- The vein-fault splits to form a more northerly striking orientation.
- The vein-fault changes to a steeper dip.

Wide veining with the development of high-grade silver mineralization is spatially associated with vein-fault domains exhibiting steeper dips and/or more northerly strikes.

6.4.1 BELLEKENO DEPOSIT MINERALIZATION

The Bellekeno vein system consists of ten known veins with variable characteristics. Vein material has been extracted from Ram, Eureka, Tundra, 48, 49, and 50 veins that generally strike 030° to 040°, with dip directions varying from 60° southeast to 80° northwest. Recent mechanized mining has focused on the stronger 48 Vein structure, while conventional historical narrower mining focused on the smaller, higher-grade vein structures.

There are three main zones within the 48 Vein structure: the Southwest, 99, and East zones with a strike length ranging between 200 m to 500 m and have been traced by drilling to over 350 m depth extent, each with distinctive silver to lead ratios, zinc content, and accessory mineral assemblages Figure 6-6.

The thickness of the vein ranges between a few cm to upwards of 5.5 m. Post-mineral faulting typically shows intense iron carbonate alteration and local brecciation while the distribution of syn-mineral faulting is observed to have a strong impact on silver grades and mineral textures (Figure 6-7). Left oblique-normal movement along the 48 Vein structure is estimated from stratigraphic offset to be approximately 35 m.

The mineralized zones appear as discontinuous steeply plunging shoots, hosted within manganese-rich siderite vein structures and may have pervasive secondary limonitic alteration when exposed to groundwater. Minerals of economic interest include very fine-grained silver-bearing sulfosalts associated with galena and sphalerite. Common accessory minerals include pyrite, arsenopyrite, and chalcopyrite while anglesite, cerussite, smithsonite, malachite, and azurite have been occasionally observed.

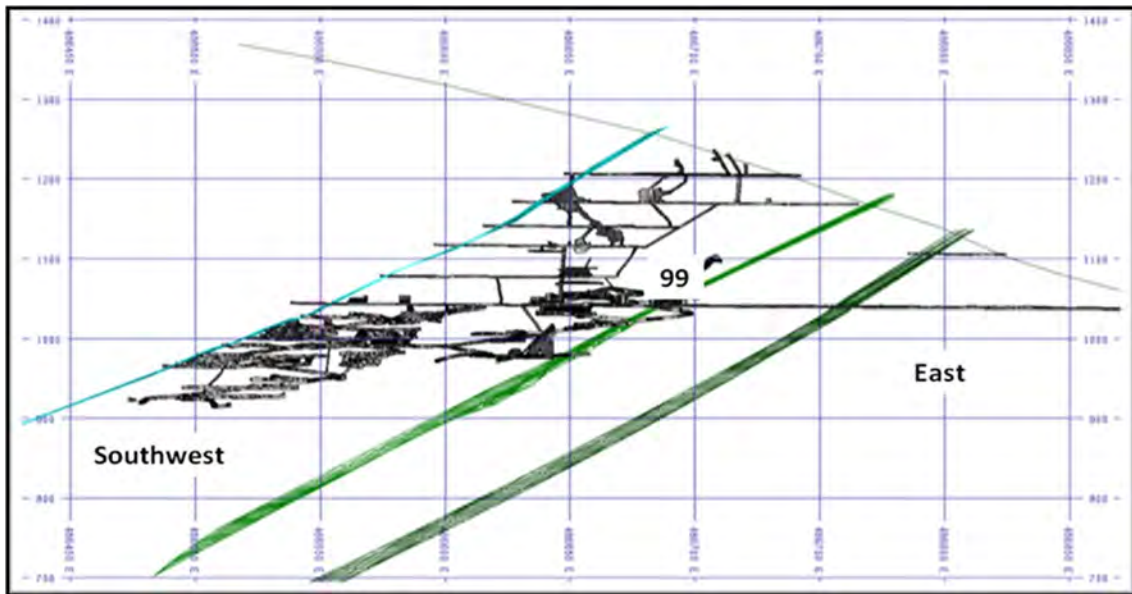
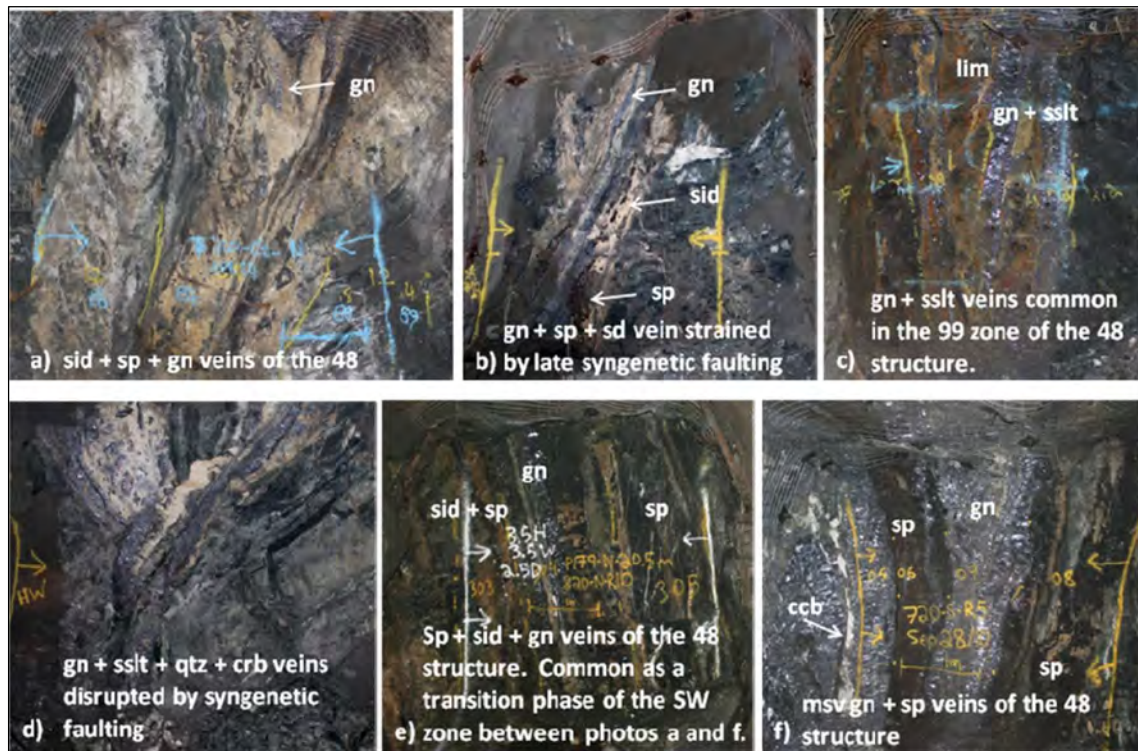

Figure 6-6 – Schematic Long Section of the 48 Vein Bellekeno Mine Showing Workings (SRK, 2013).



Abbreviations are: (gn) galena; (sid) manganese rich siderite; (sp) iron rich; (Fe 65) sphalerite; (lim) limonitic alteration of carbonate facies; (sslts) nonspecific sulfosalts; (qtz) siliceous floods and concretions associated with late breccias; (crb) white carbonate.

Figure 6-7 – 48 Vein Structures and Mineralogy, Bellekeno Deposit (SRK, 2013).

6.4.2 LUCKY QUEEN MINERALIZATION

The Lucky Queen vein-fault structure is essentially a singular structure with an average strike of approximately 043°, that locally varies between 025° to 060°, and has an average dip of approximately 045° to the southeast with a range of 30° to 55°. The main structure has a drill-defined length of approximately 650 m and 230 m recognized through drilling; with vein thickness ranging from a few centimeters to several meters and is open along strike in both directions. Stratigraphic units correlated across the structure show a normal separation of approximately 30 to 35 m across the vein-fault. Mineralized zones are largely composed of brecciated wall rock, siderite (\pm limonite), vein quartz, with silver sulfosalts, galena, sphalerite, and native silver with minor arsenopyrite and pyrite (Figure 6-8).

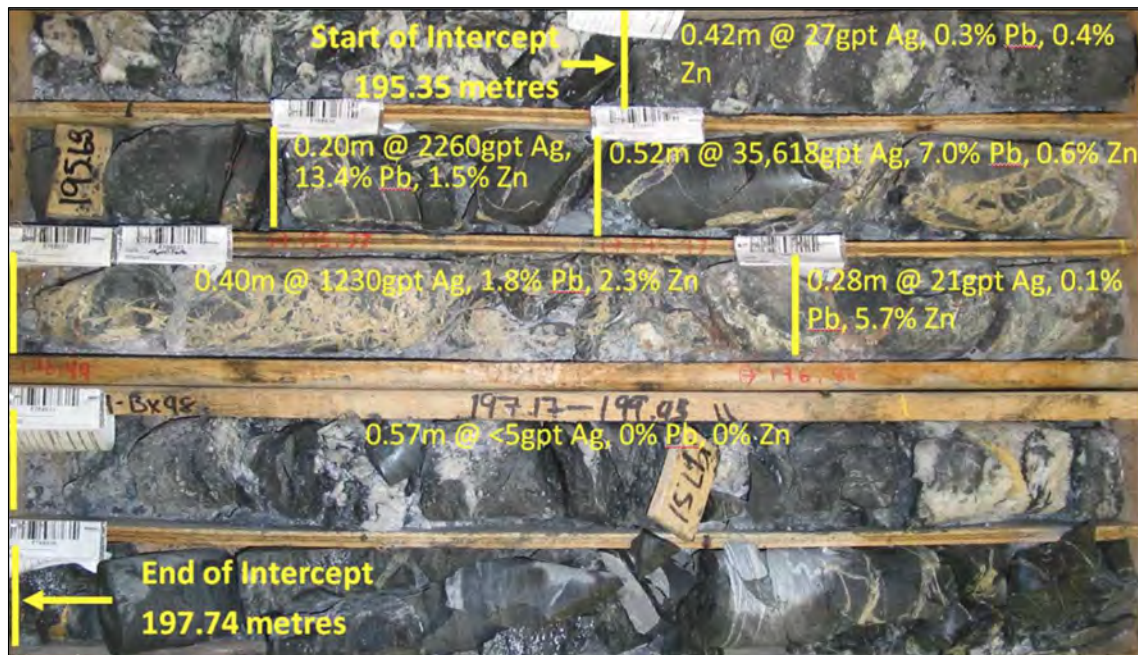

Figure 6-8 – Vein-Fault Intercept in Drill Hole K-07-0114, Lucky Queen (SRK, 2013).

6.4.3 FLAME AND MOTH MINERALIZATION

The Flame Vein is unique because of its uniformly singular form, width, grade, and length. It occurs over a strike length of one kilometer (km) orientated at a strike of 025° and dipping approximately 65° southeast and has been traced by drilling to over 300 m depth extent. Two main styles of mineralized veining commonly with multiple banding, internal brecciation, and often re-healed textures are observed (Figure 6-9). The early phase comprises dominantly quartz gangue with abundant but irregular amounts of pyrite, pyrrhotite, sphalerite and arsenopyrite, while a later phase comprises predominantly siderite containing abundant sphalerite, pyrite, galena, with minor chalcopyrite and trace amounts of tetrahedrite, pyrargyrite, jamesonite, boulangerite and cassiterite as identified in thin section samples.

The vein is divided into two parts by an approximate 90 m right lateral offset on the post-mineral Mill Fault that is referred to as the Lightning Zone in the southeast and the Christal Zone in the northwest.

The associated Moth Vein, the subject of historic prospecting, is considered to represent a footwall splay of the Flame Vein, although the relationship is not fully understood.



Figure 6-9 – Vein-Fault Intercept in Drill Hole K-12-0432, Flame and Moth (SRK, 2013).

6.4.4 ONEK MINERALIZATION

The Onek vein system comprises at least three individual vein-faults occurring within a broad northeast striking, southeast dipping structural zone. The vein-faults occur over a strike length of at least 650 m with 250 m depth extent, formed in brittle fractured or milled zones, locally containing massive sulfide vein material in, or associated with, siderite comprising sphalerite and galena along with minor pyrite, and arsenopyrite (Figure 6-10).



Figure 6-10 – Vein-Fault Intercept in Drill Hole K-10-0306, Onek (SRK, 2014).

6.4.5 BIRMINGHAM MINERALIZATION

The Birmingham zone comprises a closely spaced series of subparallel steeply southeast dipping vein sets related to the master Birmingham vein-fault system. These are identified (hanging wall to footwall) as the Birmingham, Birmingham Footwall and Bear veins that can be traced over a northeasterly strike distance exceeding 850 m. In addition, a small resource is contained in a conjugate set of related West Dipping veins. In places less extensive, north-northeast striking vein geometries are observed within the mineralized system. Recent detailed underground and surface drilling work has focused on the Arctic and Bear Zones where the vein sets are connected either laterally or vertically within the wider Birmingham vein-fault structural corridor. Mineralization extends from between 90 m to 160 m below the surface to a depth of approximately 450 m where veining remains open.

The mineralized veins are displaced by several post-mineral faults that subdivide the system into several zones used for Mineral Resource estimation purposes, with the sequence from the southwest being Etta, Arctic, Bear, and Northeast Zones separated by the Mastiff, Arctic, and Ruby B faults, respectively.

The early Aho Vein comprises predominantly quartz that occurs over several meters' width within a wide halo of structurally damaged rocks. Minor sulfides are present with arsenopyrite and pyrite being the most abundant, with accessory galena and sphalerite.

The Birmingham Vein has a strike between 029° and 042° and dips between 40° and 64° to the southeast and the structure accommodates approximately 65 m of the total Birmingham displacement. In the Etta Zone, and within the hanging wall of the post-mineralization Mastiff fault, the Birmingham vein at its most southwestern extent is observed to converge with the Aho Vein structure; while to the northeast, it converges with the Birmingham Footwall vein.

The Birmingham Footwall Vein has a strike of between 040° and 060°, and dips between 67° and 73° to the southeast, and the structure accommodates approximately 70 m of the total Birmingham displacement. In the Etta Zone, the Birmingham Footwall Vein terminates against the Birmingham Vein up-dip and this intersection plunges moderately steeply to the northeast into the Arctic Zone in the footwall of the post-mineral Mastiff fault. At depth, the Birmingham Footwall Vein terminates against the Aho Vein along a steep plunging north-easterly trajectory.

The Birmingham and Birmingham Footwall veins typically exist within a 5 m to 10 m wide structurally damaged zone containing numerous stringers, veinlets, breccias, and gouge and generally form a discrete silver mineralized vein 0.5 m to 2.5 m wide within this zone. It consists predominantly of carbonate (dolomite, ankerite, siderite, and calcite), and quartz gangue, with the sulfides galena, sphalerite, pyrite, and arsenopyrite, and accessory, chalcopyrite, argentiferous tetrahedrite (freibergite), jamesonite, pyrrargyrite and native silver (Figure 6-11).

The Bear Vein strikes between 010° and 050° and dips between 65° and 80° to the southeast and accommodates approximately 30 m of the total Birmingham displacement. It occupies a position in the footwall of the system beneath a major flexure in the Birmingham Vein, with which it joins up-dip. At

depth and to the southwest, the Bear Vein junctions with the Birmingham Footwall Vein. Early phase mineralization is absent, and the Bear structure is considered a late response to the slip-impeding flexure in the Birmingham Vein noted above, with the high-grade silver mineralization located on the more northerly striking and steeper dipping areas.

The West Dipping Vein is located between the Bear and Birmingham veins and it strikes 020° and dips 50° to the west. It displays only minor displacement that is considered to represent an adjustment due to a pronounced curvature in the hanging wall surface of the Bear Vein. Similarly, oriented veins were observed historically in the Keno Hill District in the Elsa, Husky, Runer, and Black Cap mines and are also interpreted at Hector-Calumet and Lucky Queen (Boyle, 1965; Cathro 2006; UKHM, 1997). The Bear and West Dipping veins are structurally and mineralogically similar to the Birmingham Vein, although early quartz and calcite are less abundant or absent, whilst silver sulfosalts are more abundant. This difference is considered a product of a shorter period of later deformation on the Bear and West Dipping vein faults that provided mineral depositional sites only during the latter stages of the mineralizing cycle.

The post-mineralization faults that are recognized within the Birmingham resource area include the Mastiff, Hanging Wall, Arctic, Ruby B, and Super faults. The attitude of these southwest dipping faults appears bimodal, with one set striking at approximately 285° and another at approximately 315°, and likely represent end members of a single fault set. These northwest-trending structures cut and displace all mineralized veins, and while they are typically non-mineralized, it is sometimes observed that mineralization may have been dragged into the later fault.

The Mastiff Fault has an attitude of 137° / 51° SW and displaces the hanging wall obliquely 131 m down to the northwest along a vector of 302° / -23°. Its location is well constrained by drilling and exposure in the main pit. When discussing the location of the mineralization, the vein zones located to the east in the footwall of the Mastiff Fault are referred to as the Arctic, Bear, and Northeast zones, and as the Etta Zone in the west in its hanging wall.

The Hanging Wall Fault strikes between 000° and 025° and dips easterly at between 53° and 65° and is represented in the drill core by very wide (10 - 30 m) zones of unconsolidated fault breccia and gouge, with sporadic weakly developed mineralization that occurs as trails of fragmented clasts interpreted to represent pre-fault material. The Hanging Wall Fault extends to the surface where it was intersected by historic trenching northeast of the current resource area.

The Arctic Fault strikes between 120° and 130° and dips between 45° and 68° to the southwest and displaces all veins 76 m down to the southwest along a vector 274° / -29°. It includes two sub-parallel splays, and their generation is considered a response to a strong flexure in the main fault shape. A splay off the Arctic Fault, named the A Fault, is mapped in the open pit but this does not appear to have significant displacement and does not affect the current resource area.

The Super Fault is exposed in the eastern end of the open pit where the fault surface exhibits a thin skin of fault breccia on an undulating surface that has an average altitude of 133° / 25° SW with the hanging wall displaced approximately 42 m down to the southwest along a vector 272° / -15°. The structure is well

represented in the drill core and separates the mineralization in the shallow historic underground mine workings and open pit from the current resource area which is wholly situated in its footwall.

The Ruby B Fault strikes between 115° and 130° and dips between 60° and 70° to the southwest and separates the Bear Zone mineralization from the Northeast Zone by approximately 60 m right-lateral offset. A similar separation of veining is observed on the fault within the historical underground Ruby Mine located approximately 200 m to the northwest.

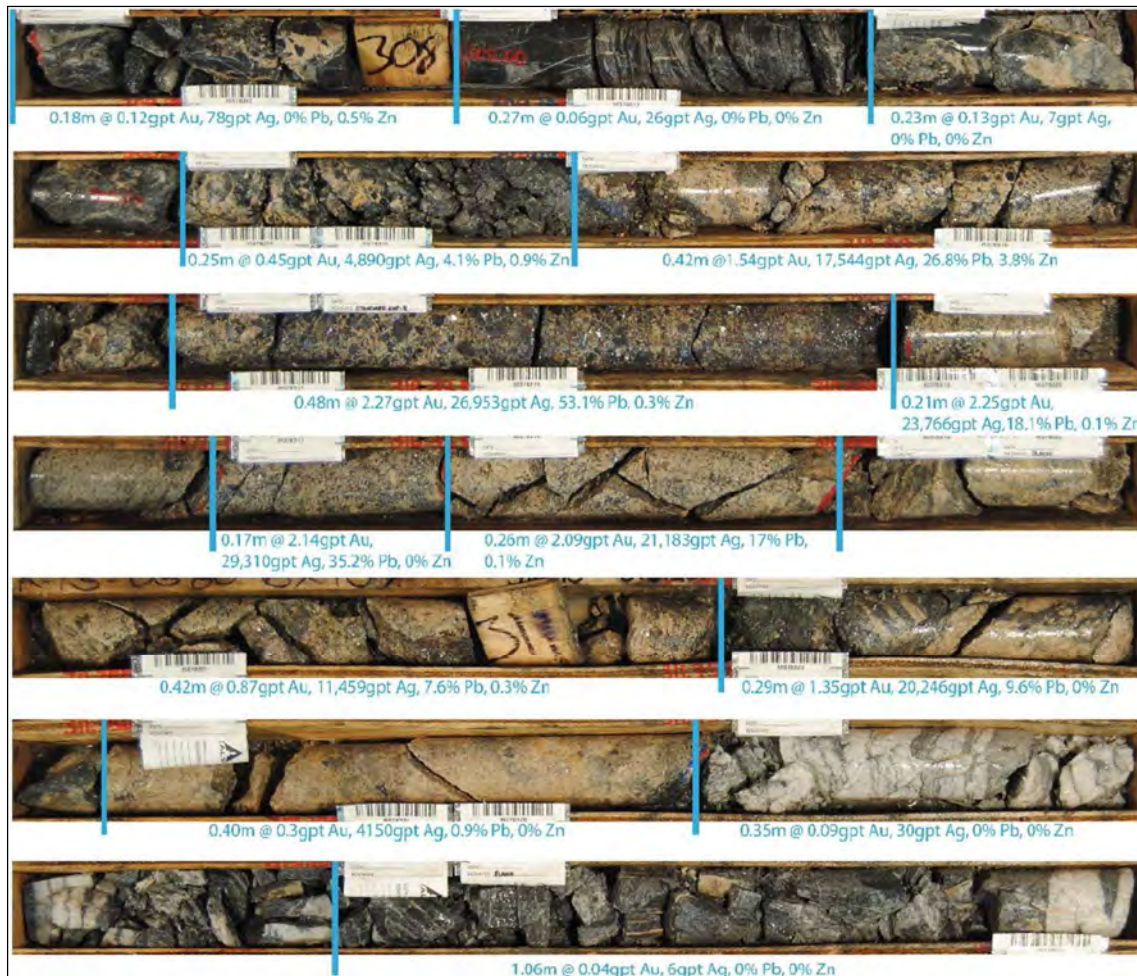

Note: for the interval 307.82 – 313.16 m, being a 5.34 m interval that composited at 9,250 g/t (297.4 oz/t) Ag, 10.9 Pb and 0.4%Zn.

Figure 6-11 – Vein-Fault Intercept in Drill Hole K-15-0580 in the Bermingham Deposit (Mining Plus, 2019).

6.5 DEPOSIT TYPES

The Keno Hill deposits do not readily fit into a recognized mineral deposit model and attempts to classify a “deposit type” for the mineralization are questionable given that the source(s) of metals and conditions related to ore-deposition are poorly understood.

Beaudoin and Sangster (1992) classified the Keno Hill as sediment-hosted veins, likened to the silver bearing deposits in the Coeur d’Alene Mining District, USA and the Kokanee Range, Canada. A genetic relationship between silver-lead-zinc and intrusion-related gold mineralization has also been postulated (Mair et al., 2006).

The mineralization has been more recently classified as belonging to the Lithogene genetic group (Greybeal and Vikre, 2010) which invokes a depositional environment of re-mobilized metals, with no magmatic contribution or associated gold.

Current information, however, shows that this latter classification is not correct, as there is some magmatic component, with local felsic intrusives acting at least in part as a heat source for hydrothermal fluid circulation, and gold is associated with the mineralization.

Mineral precipitation occurred within the thick sequence of clastic metasedimentary rock from hydrothermal fluids at temperatures from 250°C to 400°C and estimated depths of up to 11 km. Mineral deposition probably occurred in multiple pulses in response to pressure and temperature changes as boiling or fluid mixing took place preferentially in structurally prepared open spaces primarily in the competent Basal Quartzite Member and Greenstone lithologies. The source of the metals is not fully known and could be leached from crustal rocks by hot circulating fluids or derived from late-stage fractionation of the intrusives.

7. EXPLORATION

The Keno Hill mining District exploration history dates to the beginning of the 1900s with early gold prospecting near the Mayo township. In 1903, the first silver mineralization was found followed by small-scale manual mining in 1913 at Silver King.

Following a lull in activity during and after the Second World War, a new company Keno Hill Mining Company Ltd, which was later renamed United Keno Hill Mines Ltd, purchased properties, and commenced production opening a new period of exploration activity. The peak of mining activity during the 1950s and 1960s saw the discovery of new deposits across the area with increased production from larger underground complexes such as the Hector Calumet camp.

United Keno Hill Mines (UKHM) undertook extensive exploration in Keno Hill until the mines closed and production stopped in 1989 (Cathro, 2006). The bulk of this historic exploration work was completed by driving along vein structures. This activity was complemented by underground drilling designed to explore and extend mineral resources in the underground mines together with extensive surface drilling, mapping, and district-scale geophysical surveys. It is beyond the scope of this report to describe all the historical exploration work completed in the District and only the relevant historical work is referred to below.

Despite the project’s long history, the exploration work conducted by Alexco Resource Corp after 2006 comprised the first modern comprehensive exploration effort in Keno Hill since 1989. Alexco’s initial work commenced with a program of digital scanning and compiling of many UKHM mining plans, geological maps, and documents covering nearly 70 years of historic mining and compiling a coherent database comprising over 6,000 historic diamond and 16,000 overburden (RAB) drill holes. The data has been made available on a mapping platform used to construct mine scale maps and three-dimensional (3D) mine models.

During its ownership period from 2006 to 2022, Alexco completed a total of 945 surface exploration holes for a total of 240,978 m. In addition, a total of 445 underground holes for 31,318 m have also been completed, mainly at Bellekeno, but also includes 24 holes for 4,213 m drilled in 2018 from the Birmingham exploration decline. A further 34 RC holes and one sonic hole for a total of 1,242 m have been completed in the South McQuesten Valley area, exclusive of the resource definition drilling previously undertaken for the Elsa Tailings deposit. Table 7-1 provides an overview of all Alexco drilling across the District by area, from 2006 to the end of its ownership period in September 2022.

Table 7-1 – Distribution of Drill Holes Completed by Alexco from 2006 to September 2022.

Deposit	Surface Holes	Surface Meters	Underground Holes	Underground Meters	Total Holes	Total Meters
Bellekeno	72	20,227	373	23,466	445	43,692
Lucky Queen	49	11,538	4	211	53	11,749
Onek	87	13,455	12	975	99	14,430

Deposit	Surface Holes	Surface Meters	Underground Holes	Underground Meters	Total Holes	Total Meters
Flame and Moth	177	40,385	25	1,451	191	41,836
Birmingham	260	89,169	31	5,217	291	94,385
Other*	265	64,963	-	-	264	64,963
RC/Sonic	35	1,242	-	-	35	1,242
Total	945	240,979	445	31,320	1,378	272,297

*Other includes prospects Black Cap, Brefalt, Bulldozer, Coral Wigwam, Eagle, Elsa, Galkeno, Hector-Calumet, Husky, Inca, Keno 700, Leo, Mackeno, McQuesten, Mom & Son, No Cash, Ruby, Runer, Shamrock, Silver King, Tick, Townsite.

The focus of Alexco’s exploration drilling efforts primarily targeted immediately adjacent to historic mining areas with less reduced activity evaluating other structurally controlled narrow vein mineralization targets. The majority of drilling was undertaken at the five main deposits comprising Bellekeno, Birmingham, Flame and Moth, Lucky Queen, and Onek. In the area around the Flame and Moth deposit a blind exploration discovery was made in 2010 based on following up historic drill results. Further exploration has been completed beyond the central resource zone to the Flame West, Mackeno, and Northeast Flame areas, with the total drilling in the wider Flame and Moth area comprising 42,695 m in 187 surface drill holes. Exploration work in the Flame and Moth area later changed to underground drilling to support the commencement of mining operations in 2021.

During 2020, Alexco commenced underground mining development activities initially at Bellekeno and subsequently at Birmingham and Flame and Moth. The commencement of mining development shifted the focus of exploration drilling to areas adjacent to the outlined resources.

In 2021 Alexco conducted a directional drilling program which included 17,742 m of directional drilling at Birmingham Northeast Deep zone. During the periods in 2021 and 2022, Alexco suffered delays to both mining and exploration due to COVID-19 isolation restrictions and reduced staffing of personnel resulting in a reduction in productivity.

By June 2022, Alexco had suspended mineral processing operations due to a shortfall in mining production that was originally forecast to meet the 400 tons per day processing rate. Mining operations continued to stockpile material in anticipation of processing recommencing when mining rates improved.

In early September 2022, the ownership of the Keno Hill Project passed to Hecla Mining Company, owner of producing silver mines in Alaska and Idaho, USA, a gold mine in Quebec, and 14 projects in North America. Mining operations and exploration drilling activity continued throughout the change of ownership period.

Under Hecla, exploration drilling was maintained in areas in proximity to the Birmingham underground mine development. Drilling programs at Coral Wigwam and Hector-Calumet initiated by Alexco continued into the Hecla ownership period.

During the period from September 2022 to November 2023, Hecla completed a total of 93 exploration holes for a total of 25,336 m with details provided in Table 7-2.

Table 7-2 – Distribution of Drill Holes completed by Hecla from September 2022 to November 2023.

Deposit	Surface Holes	Surface Meters	Underground Holes	Underground Meters	Total Holes	Total Meters
Bellekeno						
Lucky Queen						
Onek						
Flame and Moth			11	1,059	11	1,059
Birmingham	21	8,258	41	5,581	62	13,839
Other*	20	10,439			20	10,439
RC						
Total	41	18,697	52	6,640	93	25,337

*Other includes prospects Coral Wigwam, Hector-Calumet, and Silver Spoon.

During 2023, Hecla completed surface exploration drilling using two rigs with a focus on the vicinity of the historic Silver King mine and the Coral Wigwam area, approximately 800 m along a west-southwest structural trend from the Birmingham deposit. The drilling completed by Boart Longyear comprised 8 holes for 4,001 m. Early indications from shallow geology-defining drill holes in the Coral Wigwam area identified a structural geology framework similar to that which hosts the Birmingham deposit.

7.1 SURFACE SAMPLING AND MAPPING

A district-wide surface geological mapping and structural study which started in 2007, was completed in 2018 with a revised Geological Map of the Keno Hill District being published in conjunction with the Yukon Geological Survey in 2021.

Limited historical trenching work was completed along vein strike extensions, with very limited assaying and little geological information documented.

In 2013, Alexco completed a six-trench program totaling 375 m on Galena Hill between the Birmingham and Hector-Calumet historic mines.

7.1.1 LUCKY QUEEN

At Lucky Queen, the district-wide surface geological mapping and structural study took place from 2007 and was continued through the 2012 field season with findings incorporated into the Lucky Queen geologic model where applicable.

7.1.2 FLAME AND MOTH

During 2010, a soil geochemical survey was completed in the Flame and Moth area defining anomalies that were tested in a follow-up program of 32 drillholes for 7,150 m in 2011 with the results leading to the publication of the initial resource estimate (SRK, 2012a).

7.1.3 BIRMINGHAM

In 2010, a soil-gas survey was conducted along a 2,200 m long by 175 m wide corridor stretching from Coral-Wigwam, over the historic Birmingham pit area, to the Townsite mine. An induced polarization and resistivity geophysical survey was conducted over the same area. As a result of these surveys, some anomalies were identified on the Birmingham trend along the strike southwest of the historic open pit workings and these remain as future drilling targets.

The soil-gas survey, in conjunction with the district-wide geological mapping and structural study, detailed re-mapping of the historic Birmingham open pit, and interpretation of drill results have been used to resolve the stratigraphy and structural complications at Birmingham and to further refine vein targeting.

7.2 UNDERGROUND SAMPLING

Sampling of the underground production faces is conducted regularly, occurring at each advance with a frequency ranging from 1.5 m to 3 m, depending on the advance length. This involves using a hammer and chisel with the chip channel sampling method.

The samples are collected between the hanging wall and footwall contacts of mineralized zones, with common lengths being 1.0 and 1.5 meters. However, it has been noted that a small proportion of the samples (4% of face samples) deviate from these common lengths, with some as short as 0.30 m and others exceeding 3.00 meters, reaching up to 7.21 meters.

Upon analysis at the in-house laboratory, it was observed that the assay results could show a positive bias from the long-range model and mill head grades. The exact reasons for this bias remain unclear, but it is

hypothesized that it may be attributed to oversampling influenced by the physical properties of the higher-grade zones currently under investigation.

The sampling has been conducted in Onek, Bellekeno, Lucky Queen, Bermingham, and Flame and Moth. However, in the resource estimation process, face samples have been excluded, except for Bellekeno, which was included in the estimation process undertaken by SRK Consulting Inc. (SRK) in 2013. To address potential bias during resource estimation, factoring has been applied to the face samples. As of now, there have been no significant changes in Bellekeno, and consequently, SRK’s resource model has not been updated.

7.3 EXPLORATION DRILLING – 2006 TO 2023

In 2006, Alexco purchased the UKHM Keno Hill project and commenced exploration activities including an active surface exploration program. Core drilling during 2006 was performed by Peak Diamond Drilling, of Courtenay, British Columbia, utilizing two skid-mounted drill rigs, an LF-70 drill, and an EF-90 drill. Drilling employed the wireline method using N-size equipment (NQ2). Drilling in 2006 focused on several target areas that included the Bellekeno, Lucky Queen, Ruby, Shamrock, Silver King, and Husky deposit areas. In 2007 and 2008, core drilling was performed by Quest Diamond Drilling, of Abbotsford, British Columbia, utilizing four skid-mounted drill rigs, two LF-70 drills, and two LF-90 drills in 2007; and two skid-mounted drill rigs, one LF-90, and one QD-4 drills in 2008. Drilling employed the wireline method using H-size equipment (HQ).

The 2009 surface drilling was performed by Kluane Drilling of Whitehorse, Yukon, utilizing two skid-mounted KD-1000 drills. Drilling employed the wireline method using N- and H-size equipment.

Surface drilling in 2010 was split among three contractors: Cabo Drilling of Surrey, BC, Kluane Drilling of Whitehorse, Yukon, and Ensign Encore Drilling from Calgary, Alberta.

In the period from 2011 onwards, the Boart Longyear drilling company based in Calgary completed much of the surface drilling extending through the project ownership period from Alexco to Hecla. Drilling has been conducted predominantly with LF70 and LF90 wireline drill rigs or an LX11 multipurpose rig for RC pre-collar and diamond tail drillholes. All core was recovered in PQ, HQ, or NQ sizes.

For all programs the drilling was well supervised, the drill sites were clean and safe, and the work was efficiently completed. Diamond drill operational safety inspections were conducted on each drill rig at various times throughout the drilling programs.

Underground core drilling at Bellekeno, Lucky Queen, and Onek conducted in 2009, 2010, 2011, 2012, and 2016 was completed in NQ or HQ core size by Boart Longyear utilizing skid-mounted LM90 diamond drill rigs. Underground core drilling at Bermingham in 2018 was conducted by Boart Longyear utilizing two LM90 drill rigs and recovered, in most cases, HQ-size core.

Air rotary geotechnical/hydrological drilling programs completed at Flame and Moth and Bermingham in 2013 and 2016 were completed by Midnight Sun Drilling, based in Whitehorse, Yukon, utilizing a Sandvik Marlin M5 Truck Mount rig. This drilling is not included in the drilling summary above.

Proposed surface drill hole collars were initially located using a handheld Garmin GPS device, with the completed collars being surveyed with either an Ashtech GPS device utilizing post-processing software or a Sokkia GRX1 RTK GPS.

All underground collars and drill stations were surveyed by underground surveyors (employed by Procon Mining & Tunnelling Ltd. or Alexco) using a total station survey instrument. In 2017– 2018 all underground surveying was undertaken by Alexco personnel with drill hole collar orientations set by Reflex Gyrocompass.

All coordinates are recorded in the Universal Transverse Mercator (UTM) NAD 83 Zone 8 map projection system. Up until 2010, downhole surveys were recorded using Reflex survey tools at regular intervals between 15 m and 30 m depending on the hole location and geologic conditions. Since 2011, surface holes have been surveyed progressively down holes at 24 m intervals using Reflex single shot tools, while underground surveys have been by Reflex Multishot at 12 m intervals obtained on retreat from the hole.

In early September 2022, the ownership of the Keno Hill Project was passed to Hecla Mining Company. Mining operations and exploration drilling activity continued throughout the change of ownership period.

Hecla retained Boart Longyear as diamond drilling contractor for surface exploration drilling. A large portion of the geologic diamond drilling program in 2023 comprised surface and underground drilling at Bermingham and Flame and Moth to support the mining operations and extend the near-mine mineral resource. Through 2022 and 2023, one underground rig from Boart Longyear completed underground coring programs initially at Flame and Moth followed by drilling at Bermingham.

The database’s cut-off date for drillholes included in this report is October 30, 2023.

7.3.1 BELLEKENO DEPOSIT

A series of surface and underground core drilling programs have been conducted on the Bellekeno deposit since 2006. The combined drilling programs by Alexco have produced 43,693 m of drill core from 445 drill holes targeting mineralized zone extensions including the Ram, Eureka, and 48 Vein systems, including the projected southwest Thunder Zone extension of the 48 Vein and the northern extension at the Balto prospect. Results were used to verify historical results and for mineral resource estimation (Wardrop, 2009).

The drilling programs conducted included surface drilling totaling 20,227 m of HQ core in 72 surface holes and 23,466 m in 373 underground holes; the underground holes were mostly HQ except for 79 NQ holes totaling 5,095 m). Since the interim closure of the Bellekeno Mine in 2013, modeling of the mine geology

has assisted in the development of a Keno District exploration model that has helped to develop an understanding of the structural controls of mineralization.

The Bellekeno Mine commenced operations in 2011 and at that time was Canada’s only operating primary silver mine. Mining operations were suspended in 2013.

The last drill hole completed at Bellekeno was in 2015 and no further drilling has been conducted by Hecla following the change of ownership.

Underground mining was restarted at Bellekeno by Alexco in 2021 to provide short-term ore supply for the processing plant to expand longer-term operations at Birmingham and Flame and Moth. Toward the end of 2021, Alexco reported that the underground assets at Bellekeno had been removed and redeployed with the mine transitioned to long-term monitoring.

7.3.2 LUCKY QUEEN DEPOSIT

Drilling in the Lucky Queen prospect area in 2006 totaled 875 m in four surface core holes that targeted the vein structure below the southwest end of the historic workings and around the lowermost reaches of the internal winze.

Further drilling late in the 2007 season consisted of 557 m in three surface core drill holes; however, only one reached the target depth before inclement weather forced an end to the program. In 2008, a further twelve surface core holes totaling 2,999 m were completed as step-outs along the strike of the vein to the southwest. Closer spaced and infill drilling around the 2007 drill hole intercept was the focus of the 2009 and 2010 programs when a total of 6,673 m drilling was completed in 28 surface holes to form the basis for a resource estimate (SRK, 2011a).

Following partial rehabilitation of the historic 500-level adit in 2013, four underground core holes totaling 211 m were drilled outside of the resource area.

A district-wide surface geological mapping and structural study started in 2007 and was continued through the 2012 field season with findings incorporated into the Lucky Queen geological model where applicable.

No further drilling has been conducted by Hecla since the change of ownership with the last drilling completed in 2017.

7.3.3 FLAME AND MOTH DEPOSIT

Field mapping in the vicinity of shallow historic prospect workings on the Moth Vein identified the presence of a north-northeast trending vein-fault interpreted to have a displacement of approximately 450 m based on the offset of local stratigraphy (McOnie and Read, 2009). In conjunction with the review

of past exploration results on the property, this led to the generation of drill targets and the completion of 3,986 m of drilling in 14 drill holes in 2010 that included the Flame Vein discovery hole (Drill Hole K-10-0264) intersecting 693 g/t silver over a 4.64 m interval.

In 2010, a soil geochemical and a ground magnetic geophysical survey were also completed over the area. A further 32 drill holes for 7,150 m were drilled in 2011 with the results leading to the publication of the initial resource estimate (SRK, 2012a). Follow-up drilling of 49 drill holes for 10,325 m completed in 2012 supported a revised resource estimate (Farrow and McOnie, 2013).

In 2013, an additional eight drill holes were completed for 1,835 m, extending the strike length of the mineralization for at least 220 m to the southwest to a total of over 900 m. Several ground geophysical surveys were also undertaken at this time; however, these were not successful in delineating the mineralization.

Drilling completed in 2014 comprised 53 holes for 13,360 m that was largely designed to increase the source data to support an updated resource estimate (RPA, 2017) and to explore further along the strike to the southwest.

Initial portal development of approximately 20 m was completed by Alexco in 2016. In total, 17 geotechnical underground drill holes were completed along the proposed decline trace, for a total of 572 m. By the end of September 2018, the decline had progressed to 312 m and a further 11 geotechnical holes combined with metallurgical drilling were completed for 1,167 m; one hole for 113 m was completed in 2020.

In early 2021, Alexco completed an additional 6 surface diamond holes for 781 m while development of the underground decline continued. Drilling was conducted by drilling contractor Boart Longyear using an LF70 rig.

At the end of March 2022, the Flame and Moth underground development had reached the planned ore mining levels.

With the availability of access into the underground, drilling in the first half of 2022 shifted to a series of underground diamond holes with the completion of 8 holes for 879 m in May and June 2022. Drilling was reduced during the change of ownership period until later in 2022 when Hecla completed 11 holes for 1,059 m. During the 2022 period, drilling was completed by Boart Longyear in HQ core size for all drillholes completed by Alexco and Hecla. No drilling was completed at underground or surface locations during 2023.

7.3.4 ONEK DEPOSIT

Drilling on the Onek prospect in 2007 totaled 13 surface core drill holes for 2,803 m that targeted the down-plunge extension of the mineralization outlined in the historical workings. Twenty-nine surface

core drill holes for 5,130 m were drilled in 2008 as infill and extension around the well-mineralized 2007 intercepts and targeted the historical resource blocks. No work was completed in 2009, but renewed focus in 2010 saw an additional 29 surface holes drilled for 3,694 m farther along the strike to the southwest of the historical workings. Infill drilling to the southwest was completed in 14 surface core holes for 1,295 m in 2011 and in 2012 two surface holes for 532 m were drilled along strike to the southwest outside of the resource area.

The drill data and detailed open pit mapping were used to construct a geological model that formed the basis of the initial resource estimate completed in 2011 (SRK, 2011b).

Following the drilling of a 237 m long surface core portal cover hole in 2012, a 220 m decline was driven northwest from the Lightning Creek valley and remains just short of the mineralized vein system. In 2013, eleven underground core holes for 739 m were drilled.

No further exploration drilling has been completed by Alexco or Hecla after the underground diamond drilling in 2013.

7.3.5 BIRMINGHAM DEPOSIT

The first targets generated in the Birmingham area were drilled by Alexco in 2009 with two holes completed for 523 m. The Birmingham Vein was targeted at depth in the hanging wall of the Mastiff Fault below an area where a historic shallow open pit resource had been outlined by UKHM and some anomalous silver drill hole intercepts existed. The results of this drilling were sufficiently encouraging to continue exploration in 2010 and 2011 when an additional 34 holes were completed for 9,933 m.

Seventeen drill holes were completed for 5,576 m in 2012 to identify southwesterly extensions of the vein system and to investigate vein continuity to the northeast into the footwall of the Mastiff Fault. This drilling was incorporated into an initial Mineral Resource estimate for the Etta and Arctic Zones completed (SRK, 2012b).

Eight drill holes were completed for 2,667 m in 2014, to establish continuity of the northeastern extensions of the mineralization, and in 2015, a further eight drill holes were completed for 2,606 m to follow up on a very high-grade intersection on what is now recognized as the Bear Vein in the footwall of the Birmingham Vein. A revised mineral resource estimate was prepared in 2015 (RPA, 2017).

Fifty drill holes were completed for 17,371 m in 2016, to define the extent of this high-grade Bear Vein and to better understand vein geometries and the position of some post-mineral faults known in the area. As reported later, the drilling was completed at sufficient intercept spacing to allow an updated resource estimate (RPA, 2017). In addition, because all holes had been drilled in a northwesterly direction against the dip of the target structures, and some unexplained mineralized vein intercepts could not be readily correlated, the presence of a reverse dipping vein set as seen in some historic mines was suspected. To

test this, a series of five holes for 1,729 m were deliberately drilled in a southeasterly direction which confirmed the presence of the mineralized west-dipping veins.

In 2017, a drill program was dedicated to the infill and improved definition of mineralized vein structures previously outlined at Bermingham. A total of 38 drill holes for 13,277 m were completed. Geological data from the drilling assisted with the confirmation of the geological interpretation and provided the tenor of silver grades. Mining of a 550 m underground exploration decline was completed by June 2018 to provide a platform for close-spaced infill resource definition drilling.

In 2018, the Bermingham exploration program comprised a 24-hole, 4,213 m infill underground drilling component as well as a 12-hole 4,369 m surface program for deeper and more extensive targets. Wide-spaced step-out exploration drilling comprising 25 holes for 12,965 m was completed on the Bermingham Northeast Deep zone in 2019 and 2020.

The 2020 drilling program was designed to assess the Northeast Deep target area in more detail using a nominal drill intercept spacing of 100 m along strike and 50 m in dip separation with all holes drilled from the surface. Completed drilling confirmed the Northeast Deep zone mineralization lies within a structurally complex corridor with a varying horizontal to shallow northeast plunge. The drilling results outlined a strike extent of 550 m and a dip extent of up to 100 m. The company considered an additional 400 m strike zone extended toward the southwest through the Bear, Arctic, and Etta target zones with a more moderate northeast plunge. The location of this drilling is shown in the long section presented in Figure 7-1.

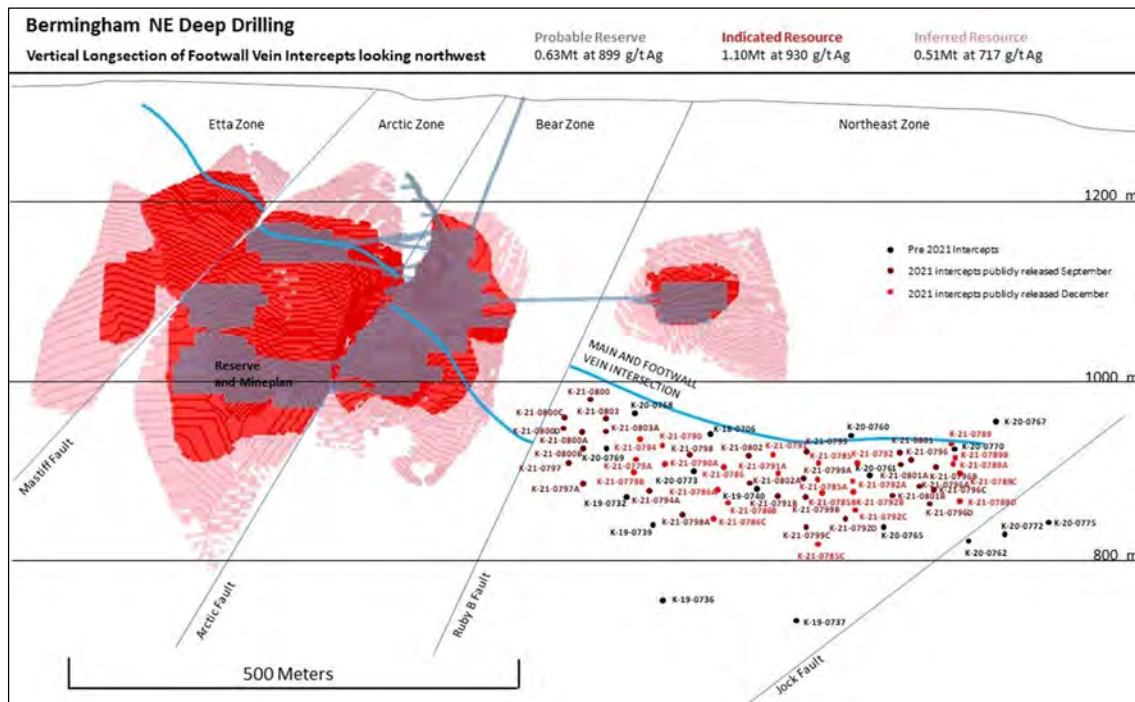

Figure 7-1 – Long Section Showing the Location of 2020 Bermingham Northeast Deep Drilling (Alexco, 2021a).

Further drilling in the Bermingham area continued into 2021 with the location of hole paths depicted in Figure 7-2. The completed program provided a nominal intersection spacing of 35 m in strike and 25 m in dip separation along the subparallel Bermingham Main and Bermingham Footwall veins. The program incorporated directional drilling methods from surface drill sites to maximize the opportunity from the completed meters. The drilled intercepts confirmed the varying northeast plunge with observed mineralogy showing characteristics similar to the nearby Bermingham deposit. The mineralized widths ranged up to 20 m coincident with changes in strike and dip of the hosting fault structure in response to variations in rock competency and proximity to the intersection of the two veins. The accumulated drilling extended over a strike extent of 900 m primarily characterized by thick-bedded quartzites of the Keno Hill Quartzite that also hosts the nearby Hector-Calumet deposit.

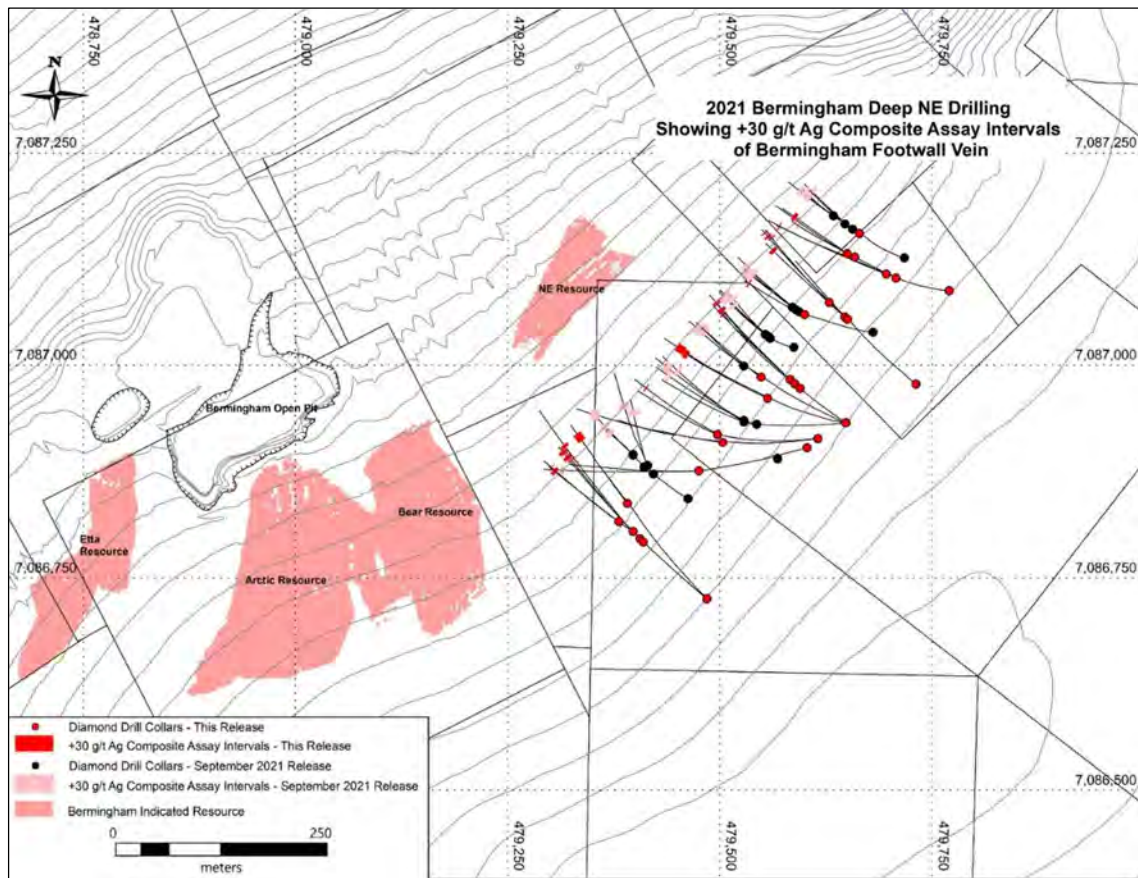

Figure 7-2 – Location Plan Showing Bermingham Deep Northeast Drill Holes (Alexco, 2021d).

The results of the district-wide surface geological mapping and structural study have been used in conjunction with the interpretation of the drill results and detailed remapping of the historic Bermingham open pit to resolve the stratigraphy and structural complications at Bermingham and to further refine vein targeting.

From early September 2022, the ownership of the Keno Hill Project passed to Hecla Mining Company; mining operations and exploration drilling activity continued throughout the change of ownership period.

In 2022, Bermingham exploration reverted to underground drilling from within the mine to test the Arctic Vein followed by further underground drilling in 2023. Of the 62 holes completed during 2023, 39 were drilled from underground at Bermingham testing the Arctic Vein and two holes were drilled into the Townsite Vein. The remaining 21 holes were drilled from surface locations for an aggregate of 8,258 m. All drilling of surface and underground holes in recent years was completed by Boart Longyear except four underground holes completed by Hy-Tech.

Significant intercepts recovered from the Bermingham UG drilling program have been presented in Table 7-3. The selection of intercepts uses a >30g/t Ag threshold where intercepts may include up to 2 m of internal waste.

Table 7-3 – Significant Intercepts from the 2023 Bermingham Underground Drilling (Hecla, 2023c).

Drillhole	Azi/Dip	Sample From (m)	Sample To (m)	True Width (m)	Ag g/t	Zn %	Pb %	Zone
BMUG23-037	140/4	132.86	135.24	1.58	421.72	1.7	0.6	Bermingham
BMUG23-038	140/-8	158.50	158.86	0.21	106.29	0.5	0.5	Bermingham
BMUG23-039	137/-1	136.49	138.01	1.07	168.00	0.5	0.2	Bermingham
BMUG23-040	134 / -4	123.78	126.43	1.28	54.86	0.5	1	Bermingham
BMUG23-041	131 / 7	107.99	108.11	0.06	185.14	0.7	2	Bermingham
BMUG23-042	131 / 1	129.11	129.54	0.21	99.43	0.8	3.5	Bermingham
BMUG23-043	128/4	122.83	123.75	0.52	3.43	0.1	0	Bermingham
BMUG23-044	120/7	70.93	71.84	0.85	4145.18	1.5	3.3	Bermingham
BMUG23-045	116/1	75.01	78.00	2.71	216.00	0.6	0.2	Bermingham
BMUG23-046	105/12	109.09	109.55	0.30	54.86	0.6	0.5	Bermingham
BMUG23-047	97/13	111.92	112.93	0.52	65.14	0.8	1.2	Bermingham
BMUG23-048	134/-18	81.75	84.83	2.29	144.00	0.3	2.1	Bermingham
BMUG23-049	128/-7	69.62	70.99	1.25	1429.73	1.9	2.9	Bermingham
BMUG23-050	119/-6	88.51	89.95	1.07	456.00	3.2	3.6	Bermingham
BMUG23-051	119/-9	146.94	149.35	2.16	34.29	0.2	0.4	Bermingham
BMUG23-052	120/-19	175.84	178.77	1.86	2722.31	3	1.3	Bermingham

7.3.6 OTHER DEPOSITS

During the period from 2006 to 2022, Alexco’s exploration drilling efforts were primarily focused on testing targets immediately adjacent to the historic mining and resource areas with reduced emphasis on evaluating other structure-controlled narrow vein mineralization targets. The majority of the drilling completed was undertaken at the five main deposits comprising Bellekeno, Bermingham, Flame and Moth, Lucky Queen, and Onek. During Alexco’s ownership, drilling was also completed at a wide range of smaller deposits and target areas.

In the western part of the District, initial drill programs were completed at the McQuesten and the Leo prospects. The McQuesten prospect was optioned by Alexco to Banyan Gold under an earn-in expenditure agreement. At Silver King, drilling of 13,193 m in 50 drill holes was mainly focused on extending the historic resource in the No. 5 Vein in the hanging wall of the historically mined mineralization. Some significant intercepts recovered during the drilling indicated that further exploration was required of this structure, as well as along the extensions of the past producing No. 1 and No. 2 veins.

Along the Husky – Husky SW vein system, the northeastern extension of the Silver King structure, Alexco completed 12,224 m of drilling in 46 drill holes. The results of this drilling confirmed that the historically mined veins locally extend at depth beneath the mine workings, and it was considered that potential exists for locating additional mineralization.

The mineralized Birmingham vein structure, first drilled by Alexco in 2009, was spatially related to the southwest extension of the major 96 M oz historic silver-producing Hector-Calumet mine vein system and extended further southwest to the Coral Wigwam and Brefalt offset area. The mineralized structure was complex, and several interpreted veins were identified in the area. Exploration drilling in this area comprised 14,473 m of drilling in 54 surface drill holes targeting the Galena Hill area beyond the Birmingham resource and including several other subparallel mineralized vein structures such as Elsa, Townsite, No Cash, and Ruby. This drilling resulted in the discovery of significant high-grade silver mineralization and has possibly also located the Brefalt fault offset to the Birmingham system to the southwest. Other targets drilled at the northeastern end of Galena Hill at Inca, Eagle, and Galkeno have also identified mineralized intercepts that will be followed up in the future.

At the Keno Hill deposit, and beyond the drilling related to the Lucky Queen and Onek resource areas, Alexco completed exploration drilling on the Keno, Shamrock, Black Cap, and Runer vein systems for an aggregate of 19 holes and 3,717 m. In each of these locations, results and geological data collected by Alexco indicated additional exploration work was justified although no drilling has been completed after 2018.

With the commencement of mining activities in 2020, Alexco’s exploration drilling returned to focusing on the mining projects and nearby resource areas interpreted from evaluating historic exploration data.

In the first half of 2022, Alexco commenced surface exploration drilling focused on testing new targets at the Silver King, Coral Wigwam, and Hector-Calumet deposits. The Coral-Wigwam deposit area is located 800 m west-southwest along the strike from the Birmingham deposit. A plan showing the location of the exploration drilling sites relative to the Birmingham deposit has been presented in Figure 7-3.

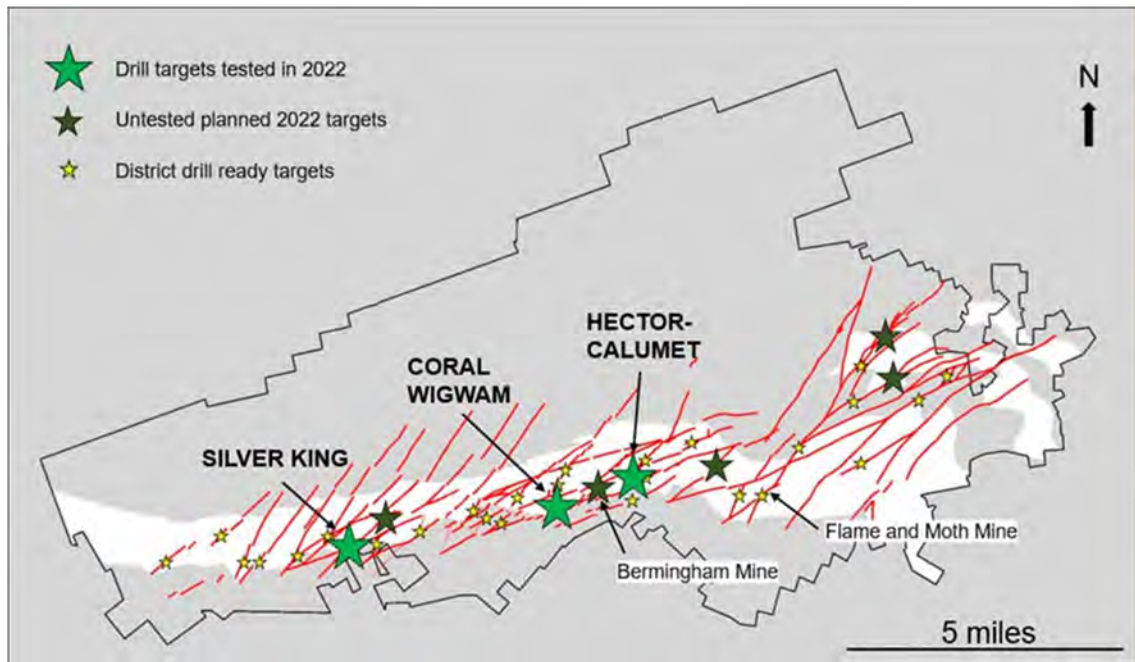

Figure 7-3 – Plan Showing the Location of 2022 Exploration Drilling (Hecla, 2023a).

Mineralization in these target areas was considered to represent structural analogs to the nearby Birmingham deposit identified through the ore control model where northeast-trending transverse structures intersect with east-northeast trending longitudinal structures.

While many areas of mineralization are hosted within the basal quartzite, several mineralized intercepts at both Coral-Wigwam and Silver King are in rocks above this favored host position. The intercepts at Silver King were located on the longitudinally oriented structures. The observation of mineralized intercepts in these sites suggested that further evaluation of the previous drilling in this area was warranted. Drilling continued in the Coral-Wigwam area, testing predominantly the Walleye Vein from May until November 2022.

From early September 2022, the ownership of the Keno Hill Project passed to Hecla although exploration drilling activity continued throughout the change of ownership period.

Significant drill intercepts recovered from the 2022 drilling program were reported by Hecla as regular press releases. Tabulated data was provided in imperial measurements which have been converted to metric using the conversion formula provided in Table 7-4.

Table 7-4 – Conversion Formula for Imperial to Metric Intercepts.

Imperial	Metric
1 foot	0.3048 m
1 troy oz/ton	34.286 g/tonne

Drilling at Silver King included multiple intersections in different splay veins with some mineralized intervals hosted in historically less productive portions of the Keno Hill stratigraphy that overlie and project into the more favorable basal quartzite. Drilling for the 2022 year included a total of 12 holes for 4,674 m. Significant intercepts recovered from the 2022 drilling program are presented in Table 7-5.

Table 7-5 – Significant Intercepts from the 2022 Silver King Drilling (Hecla, 2023a).

Drillhole	Azi/Dip	Sample From (m)	Sample To (m)	True Width (m)	Ag g/t	Zn %	Pb %	Prospect
K-22-0804	153/-51	79.52	81.72	0.58	1,330	4.7	1.4	Silver King
K-22-0804	153/-51	98.94	99.36	0.12	34.29	0	0	Silver King
K-22-0804	153/-51	160.48	161.91	0.37	34.29	0	0	Silver King
K-22-0804	153/-51	169.96	171.27	0.34	58.29	0	0	Silver King
K-22-0804	153/-51	284.99	285.45	0.12	44.57	1.1	0.4	Silver King
K-22-0808	315/-66	101.25	105.86	3.75	75.43	1.2	0	Silver King
K-22-0808	315/-66	109.76	110.22	0.37	65.14	0.3	0.1	Silver King
K-22-0810	305/-66.5	109.27	115.98	4.97	270.86	0.9	0.2	Silver King
K-22-0810	305/-66.5	118.63	123.44	3.57	672.01	0.2	0.9	Silver King
K-22-0810	305/-66.5	257.71	258.65	0.76	48	0	0	Silver King
K-22-0810	305/-66.5	262.04	262.59	0.46	168	0.3	0.7	Silver King
K-22-0810	305/-66.5	267.52	268.74	0.98	85.72	0	0	Silver King
K-22-0810	305/-66.5	271.61	272.46	0.67	68.57	0	0	Silver King
K-22-0812	300/-71	231.28	232.23	0.55	30.86	0.1	0.2	Silver King
K-22-0812	300/-71	252.8	259.99	4.11	37.71	0.4	0.2	Silver King
K-22-0812	300/-71	263.53	267	1.68	377.15	0	0.8	Silver King
K-22-0812	300/-71	294.01	299.13	3.29	78.86	0	0	Silver King
K-22-0814	288/-80	262.83	288.01	11.31	37.71	0	0	Silver King
K-22-0817	352/-64	111.47	112.68	0.91	185.14	0.7	0.2	Silver King
K-22-0819	307/-74	173.55	177.55	2.38	185.14	0	1.3	Silver King
K-22-0819	307/-74	184.53	195.25	6.43	192	0	0.5	Silver King
K-22-0824	306/-57	639.41	640.26	0.76	233.14	0.1	1.2	Silver Spoon
K-22-0824	306/-57	642.46	642.73	0.24	1,131	0	0	Silver Spoon
K-22-0824	306/-57	667.69	667.97	0.21	120	0.9	0.2	Silver Spoon
K-22-0824	306/-57	678.88	679.16	0.21	178.29	0.3	0.1	Silver Spoon

Drillhole	Azi/Dip	Sample From (m)	Sample To (m)	True Width (m)	Ag g/t	Zn %	Pb %	Prospect
K-22-0824	306/-57	684.18	685.71	1.22	109.72	0.5	0.4	Silver Spoon
K-22-0824	306/-57	696.01	696.56	0.46	54.86	0.2	0.1	Silver Spoon
K-22-0826	285/-68	722.8	728.01	2.96	37.71	0.3	0.2	Silver Spoon

Intercepts reported by Hecla are determined using a >30g/t Ag threshold and may include up to 2 m of internal waste.

The 2022 program included drilling at Coral Wigwam comprising 17 holes for 5,700 m with a further 5 holes for 3,203 m at Hector-Calumet. Drilling was completed by contractor Boart Longyear using HQ sized core with operations being largely continuous from May to November 2022, which spanned the change of ownership from Alexco to Hecla. Significant intercepts recovered from the Coral Wigwam and Hector-Calumet drilling during 2022 are shown in Table 7-6.

Table 7-6 – Significant Intercepts from Coral Wigwam and Hector-Calumet 2022 Drilling (Hecla, 2023a).

Drillhole	Azi/Dip	Sample From (m)	Sample To (m)	True Width (m)	Ag g/t	Zn %	Pb %	Prospect
K-22-0806	297/-57	156.45	156.76	0.21	205.7	0	0.2	Coral Wigwam
K-22-0809	310/-90	126.61	126.74	0.06	92.6	2	1.2	Coral Wigwam
K-22-0809	310/-90	144.44	144.96	0.24	257.1	0	0.1	Coral Wigwam
K-22-0820	295/-59	328.79	329.61	0.67	137.1	0.1	0.2	Coral Wigwam
K-22-0820	295/-59	438.88	439.61	0.58	37.7	0	0	Coral Wigwam
K-22-0825	275/-73	463.42	467.44	2.23	3,480	0.1	0.1	Coral Wigwam
K-22-0828	305/-67	380.73	383.01	1.52	168	0.4	0.3	Coral Wigwam
K-22-0828	305/-67	463.78	465.09	0.98	99.4	0.1	0	Coral Wigwam
K-22-0829	342/-67	354.36	363.84	7.5	171.43	0.5	1.1	Hector-Calumet
K-22-0832	331/-70	507.19	507.4	0.15	65.14	0	1.5	Hector-Calumet
K-22-0834	312/-65	281.36	286.15	3.6	363.43	2	1.5	Hector-Calumet
K-22-0834	312/-65	537.09	537.97	0.7	754.29	6.4	2.3	Hector-Calumet
K-22-0834	312/-65	560.01	561.35	1.07	168	2.7	2.2	Hector-Calumet
K-22-0836	300/-66	542.12	542.39	0.21	72	0.6	0.6	Hector-Calumet
K-22-0837	293/-75	369.11	373.65	3.35	360	4	1.1	Hector-Calumet
K-22-0837	293/-75	413.8	414.86	0.76	41.14	0.2	0.3	Hector-Calumet

Further drilling was completed at Coral Wigwam in August 2023 with the completion of three holes for 1,111 m which included one abandoned drillhole.

As part of the 2023 Bermingham exploration drilling program, Boart Longyear completed 6 holes for 1,856 m evaluating a mineralized extension of the historical Ruby Mine.

The plunging intersection between two vein structures was interpreted as the ore control for mineralization at the historic Ruby Mine and became a drilling target for further investigation. Drilling indicated that the structural architecture was complex preventing a clear understanding of the mineralization controls (Figure 7-4).

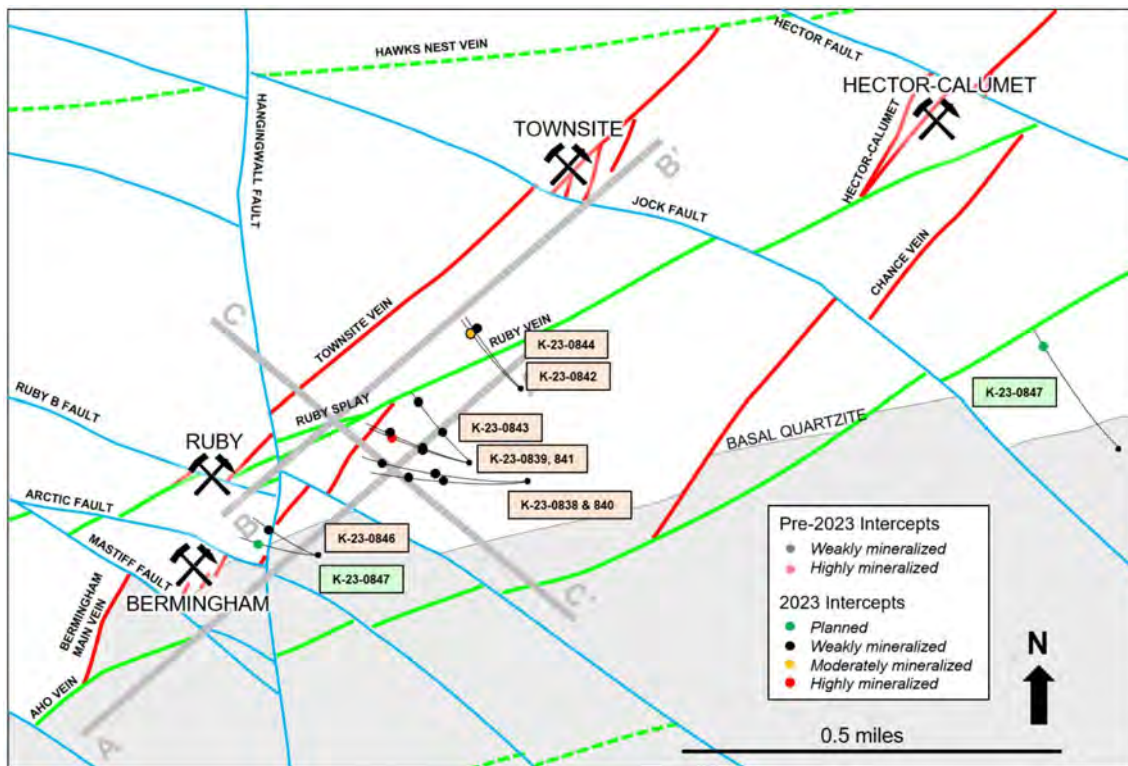

Figure 7-4 – Plan View of the Bermingham Area (Hecla, 2023b).

As part of the same 2023 exploration program, drilling was planned for the Chance Vein at the Hector-Calumet deposit. Previous drilling intersected a narrow-mineralized interval that warranted a follow-up. Four holes for 2,056 m were completed on this program before the rig was relocated to other exploration target areas.

Three vein structures project into this area between Bermingham Main and Townsite veins which comprise the Ruby, Ruby Splay, and Bear Veins. Additional drilling is required to provide details of vein orientations and mineralization controls as the planar veins do not appear to be continuous through the area. This target area warrants further drilling as it is a short distance from the planned underground infrastructure.

7.4 GEOCHEMISTRY

Historic soil geochemical surveys conducted over the area by UKHM demonstrated widespread lead-zinc anomalies near the Birmingham deposit but did not effectively outline the details of the mineralized vein-fault structures. Soil surveys were also not effective for exploration near the Flame and Moth deposit due to the irregular Pleistocene glaciofluvial cover and the shallow depth of permafrost.

7.5 GEOPHYSICS

In 2006, a wide-spaced district-scale aerial magnetic and electromagnetic geophysical survey and air photography was undertaken. Diamond drilling of prospects ranked highly as having the potential to return mineable silver resources also commenced that year with work focusing on the Bellekeno, Silver King, and Lucky Queen areas.

In late 2018, Alexco undertook a detailed aerial RESOLVE EM-Magnetic geophysical survey over Galena Hill, later extended to cover Keno Hill in 2020. The survey provided detailed structural information that in addition to the district geologic mapping defines a general 1 km periodicity of large-displacement northeast oriented transvers vein-faults that hosts mineralization assisting with the definition of drill targets. This structural understanding has substantially increased the success rate of intersecting mineralization with exploration drilling.

7.6 HISTORICAL DRILLING

7.6.1 BELLEKENO DEPOSIT

Historical percussion and core drilling for the Bellekeno area extended from 1975 to 1996, and although recovered data has been compiled, some sections are most likely incomplete.

Between 1975 and 1996, UKHM drilled four surface, and two underground percussion programs. These drill holes were logged, sampled, and assayed at four, and five-foot intervals (1.22 m and 1.52 m), respectively. Originally, percussion drilling and sampling were undertaken to mitigate the loss of vein material observed in coring programs. However, this type of drilling is considered to provide low-quality data, with recirculation of water and rock material and the nature of chip logging and was not used for resource estimation.

Core drilling programs between 1986 and 1996 were from underground and totaled 4,944 m in 60 drill holes completed by UKHM. Holes were drilled with BQ and NQ tools but generally resulted in moderate to poor recovery in areas where foliation and stratigraphy were subparallel to the core angle, or heavily fractured or friable material was encountered. Drill holes were generally designed to test for the

downward extension of the 99 Zone, with smaller programs for the Southwest and East zones, as illustrated in Figure 7-5.

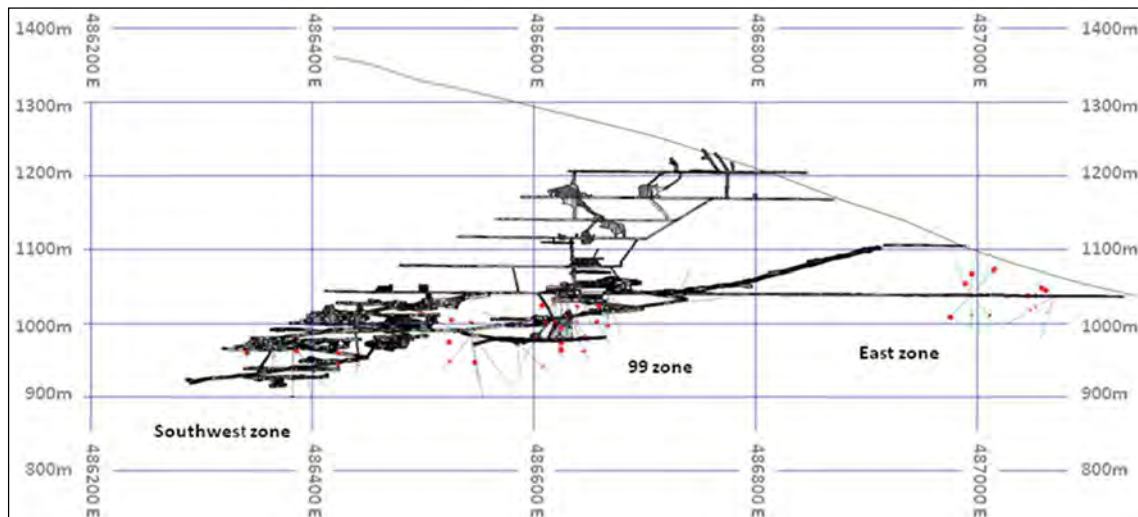

Figure 7-5 – Bellekeno Mine Long Section Looking Northwest, 1986 – 1996 UKHM Core Drill Holes (SRK, 2013).

Archived drilling data and procedures were reviewed by G. David Keller, P.Geo., of SRK as part of the updated PEA technical report issued by Wardrop in 2009. As part of this review, Mr. Keller discussed the drill core sampling procedures with UKHM staff active during the mining operations at Bellekeno. The drilling procedures were deemed reasonable based upon the limited information available (Wardrop, 2009), and thus considered reliable for geologic interpretation and resource calculations.

7.6.2 LUCKY QUEEN DEPOSIT

Historical drilling information is available for the Lucky Queen area from the 1950s through the 1980s. In 1957, UKHM drilled two surface core drill holes (Lucky Queen 2 and Lucky Queen 4) that intercepted the main Lucky Queen structure below the existing 300-level workings; however, core recovery was very poor. For example, across a 50.90 m interval (from a depth of 156.06 m to 206.96 m in drill hole Lucky Queen 4), recorded recovery averaged only 22% in the approximate vicinity of the vein because of the fractured and friable nature of vein material. No assays exist for these drill holes because vein material was either not intercepted or was not recovered and, thus, assaying was likely deemed unnecessary. In addition, survey control for these drill holes is sparse. For the above reasons, the historical surface core drilling data was not used in the Lucky Queen resource estimate.

Between 1985 and 1987, UKHM drilled underground percussion test drill holes from the Lucky Queen 500 level adit that were sampled and assayed at 4 ft (1.2 m) intervals. Percussion drilling was not considered

to reliably present an accurate location for samples and recovery data was not obtained by UKHM. On this basis, historic assays were not used in any resource estimate. The test drill holes did however provide useful geological information and were used to help constrain the geometry of the main Lucky Queen structure and associated splay structures during wireframe construction.

Shallow, rotary percussion surface drill holes were also drilled in the Lucky Queen area in the 1970's through 1980 totaling approximately 20,400 m in 507 drill holes. As with the underground rotary percussion drill holes, these data were not deemed reliable for Mineral Resource estimation although the data was used in select geostatistics (variography) and in the construction of mineralization and geological models, where applicable.

7.6.3 FLAME AND MOTH DEPOSIT

Historical drilling at Flame and Moth was dominantly shallow surface percussion overburden drill holes with 133 drill holes totaling 4,044 m drilled on an average azimuth of 320°. Nine core drill holes totaling 731 m were drilled from the surface and 13 drill holes totaling 193 m were drilled from the shallow underground workings. Core recovery was generally poor, particularly in mineralized zones which were the only intervals assayed.

Due to recovery issues for the historical core drill holes, lack of careful sampling techniques, and the open-hole nature of the percussion drilling, drilling data from these programs were not deemed reliable for use in the Mineral Resource estimation, although the data were used in the construction of geological models where applicable.

7.6.4 ONEK DEPOSIT

Historical core drilling at the Onek deposit was limited to 10 short-length horizontal underground drill holes drilled at varying azimuths with absent downhole survey data. Drill recovery was generally poor, particularly in mineralized zones, and core assays were restricted to well-mineralized zones.

Shallow, open-hole, surface percussion drilling was also undertaken in the Onek area, mainly in the historic open pit area, during the 1970s, with a total of approximately 13,000 m completed in 319 holes.

Due to recovery issues for the core holes, lack of careful sampling techniques, and the open-hole nature of the test/percussion, drilling data from these programs were deemed unreliable for use in the resource calculation. The data was used in select geostatistical analyses (variography) and in the construction of mineralization/geologic models, where applicable.

7.6.5 BIRMINGHAM DEPOSIT

Historical core drilling at Birmingham is limited to 16 core drill holes dating from 1969 located in the resource estimation area. The holes were drilled at an average azimuth of 323° and were not surveyed downhole. The average hole length was approximately 80 m with several holes ranging up to 146 m. Drill recovery was generally poor, particularly in mineralized zones, and core assays were restricted to well-mineralized zones.

A small portion of the 874 shallow, open-hole, surface percussion drill holes completed historically in the Birmingham area were focused on the present resource area, first as vertical holes in a grid pattern on approximately 30 m centers, followed later by a definition drilling program of inclined holes along strike of the vein to define an open pit target.

Due to recovery issues for the core holes, lack of careful sampling techniques, and the open-hole nature of the percussion drilling, drilling data from these programs were deemed unreliable for use in the resource calculation. The data were used in the construction of mineralization/geologic models, where applicable.

7.7 DRILL HOLE LOGGING

Standard logging and sampling conventions are used to capture information from the diamond drill core. Between 2006 and 2010 core was logged in detail using paper forms with the resulting data entered into a commercial computerized logging program either by the logging geologist or a technician. Since that time, all core logging data has been directly digitally entered into a SQL-based database with data including comments captured in separate tables including:

- Lithology: rock type, including significant fault or mineralized vein-faults, and textural modifiers.
- Structure: type of structure and measurements relative to the core axis.
- Mineralization to identify type and intensity of oxidation, metamorphic, hydrothermal, or disseminated phases, and abundance of veining.
- Alteration.
- Stratigraphy: units consistent with the surface mapping.
- Geotechnical: percentage recovery and rock quality determination and fracture intensity.
- Additionally, more detailed geotechnical data has been recorded from the Flame and Moth and Birmingham drilling.

Alexco systematically measured the core bulk density of mineralized material as well as basic rock types. Bulk density was measured using a balance and recording the weight of core pieces in air and water. The core weighed in water was not covered by wax or plastic film.

Pulp bulk density (PBD) measurements were obtained by pycnometry on select assay intervals of mineralized zones for Alexco drilling by ALS Laboratories (ALS) and AGAT Laboratories (AGAT).

7.8 QP OPINION

The Mining Plus geology QP notes that the drilling, logging, and drill core meet industry standards, and are sufficient to support Mineral Resource Estimation and makes the following comments:

- The most recent drilling campaign (between September 2022 and October 2023) incorporated drilling procedures inherited from Alexco, complemented by minor improvements introduced by Hecla. These practices have followed industry standards and are considered suitable for incorporation into resource estimation. However, the older drilling preceding Alexco typically has issues with core or chip quality, limiting their utility primarily to exploration purposes.
- The data spacing and distribution are sufficient to establish the degree of geological and grade continuity appropriate for mineral resource estimation.
- It has been detected that the logs before 2010 present a different approach for the description of the lithological code of the structure, although this difference is not considered significant for interpretation purposes, it is suggested to review the logs before 2010 to have a consistent logging.
- A constant monitoring of the Pulp bulk density with the Paraffin method should be carried out to rule out relevant biases and must be included in the procedures.
- Improve the procedures of face sampling and improve the quality of the onsite assaying to support the use of face samples in the in long-term model grade estimation processes.
- QP does not know of any drilling, sampling, or recovery factors related that would materially impact the accuracy and reliability of results that are included in the database used for Mineral Resource Estimation.

8. SAMPLE PREPARATION, ANALYSES AND SECURITY

The data supporting geological interpretations, mineral resource estimation, conclusions, and recommendations in this technical report primarily rely on core samples dating from 2006 to the present, which have been carried out by Alexco (2006-2021) and Hecla (2022-2023). In addition, Alexco conducted reverse circulation drilling, mainly in early exploration areas; however, none of the reverse circulation drilling data has been included in the resource estimate.

Sample preparation methods, analytical techniques, quality control, and security measures throughout the chain of custody were implemented by Alexco from 2006 to 2021. Hecla has since adopted these procedures with slight improvements.

Historical drilling data for Lucky Queen, Flame and Moth, Onek, and Bermingham deposits are not considered reliable and, consequently, were not utilized in the Mineral Resource estimation.

Underground face sampling has been carried out in Onek, Bellekeno, Lucky Queen, Bermingham, and Flame and Moth; however, in the resource estimation process, face samples have been excluded, except for Bellekeno, where they were considered in the estimation conducted by SRK Consulting Inc. (SRK) in 2013. To mitigate potential bias during resource estimation, factoring has been applied to those face samples. As of the present, no substantial changes have occurred in Bellekeno, and therefore, SRK's resource model has not required any update.

8.1 SAMPLING AND PREPARATION PROCEDURES

8.1.1 HISTORIC DRILL SAMPLING

Available documentation describing the historical (pre-Alexco and Hecla) sampling procedures and methods is limited and has been outlined below.

A 1965 UKHM document outlined the sampling procedures for a newly purchased percussion drill. It was found that in most cases the frozen ground gave sufficient support for the drill hole without additional casing. In a few cases where the ground was not frozen, the casing was advanced with the drill bit.

Drill cuttings were collected using a locally designed cone-shaped deflector with a catch pan shaped to fit around the casing. During drilling operations, cuttings were blown upwards between the drill rod and the casing, where they hit the deflector and were caught by the catch pan. Drilling runs were 5 ft (1.5 m) in length and provided 10 lb to 15 lb of sample material.

At the end of each shift, several hundred grams were split from each sample in the geochemical laboratory; the remainder of the sample material was screened to -14 mesh. Constituents of the fine and coarse fractions were identified separately.

There is no information about quality control measures employed prior to sending samples to an analytical or testing laboratory. As part of the security measures taken for Alexco to ensure the validity and integrity of samples carried out by UKHM, different projects were carried out that are described below.

All accessible core drill hole logs were transcribed onto standardized spreadsheets as close to verbatim as possible. Original logs were scanned, and file names and numbers were recorded into the new spreadsheets. These initial spreadsheets were inspected by geologists for consistency. The next step was to “normalize” the original transcribed data to match the current nomenclature; data verification was ongoing. Collar information, as well as survey, assay, and recovery data, were then verified by a person other than the original data entry person. The final step involved the amalgamation of separate spreadsheets into one global database.

Bellekeno underwent three phases of core drilling: 1986, 1994–1996, and 2006–2013. Alexco’s access to mine workings in 2009 allowed the resurveying of the 1986 and 1994–1996 historical (UKHM) drill hole collars in UTM coordinates, thereby assuring all collar locations were recorded in a common datum.

In instances where 2009 underground drilling and historical drilling were twinned, the positioning of the 2009 composite locations was honored, as historical down-hole surveying was irregularly spaced or not done at all.

In instances where surface drilling and underground drilling had conflicting contact locations, 2009 underground drilling was honored. This was the case in the Southwest zone with surface drill hole K-07-0101. The vein intercept in this drill hole is 376 m downhole. Within 15 to 20 m on each side are two Alexco underground drill holes of 15 m length of similar grade and thickness. In this case, the grade from K-07-0101 was used in the estimation but the vein position was assumed to be defined by the adjacent underground drill holes.

Drilling programs under the supervision of UKHM were given careful scrutiny prior to being incorporated into the Alexco resource estimation. Historic data was evaluated and checked by processing paper drilling logs into electronic formats, resurveying underground drill hole collars, and twinning historical vein pierce points. Early programs were deemed reasonably complete and accurate for the purpose of resource and geologic modeling.

Two phases of underground core drilling occurred at the Bellekeno mine under UKHM management, 1986 and 1994-1996. During this time, most of the drilling operated off the local Treadwell grid system. For verification purposes, Alexco resurveyed the collar positions of the core and percussion drill holes in 2009 in the areas where the mine rehabilitation had been completed. The collar data was then verified against the UTM NAD 83 Zone 8 map projection coordinates. Only minor discrepancies were found in the underground percussion drilling. Although the collar positions were updated, these drill holes were not included in the resource evaluation.

As part of the due diligence for the 2009 updated Preliminary Economic Assessment (PEA) conducted by Wardrop (2009), the twinning of the core drill hole vein pierce points was conducted. Twinned intercepts were commonly within 0.5 m to 1.5 m of the original pierce point. In most cases, the intercepts of both

drill holes were commonly useable for interpretations. However, in instances where the two pierce points were significantly different, the 2009 underground drilling was given precedence. Surface drill holes were assumed to have more deviation because of the greater down-hole depth, and irregularly spaced or incomplete down-hole survey data.

Historical drilling data for Lucky Queen, Flame and Moth, Onek, and Bermingham deposits are not deemed reliable and, therefore, were not considered for Mineral Resource estimation.

8.1.2 HISTORICAL REVERSE CIRCULATION SAMPLING

A document by Watts, Griffiths, and McQuat (WGM, 1994) outlined sampling procedures for the reverse circulation drilling carried out prior to the Hecla acquisition. Two samples were collected for each 5 ft (1.5 m) interval. One sample was sent to the laboratory while the other sample remained at the drill site for reference. The samples were collected in porous plastic bags and were dried prior to analysis. The document stresses cleanliness during the sampling procedure to avoid contamination.

8.1.3 CORE DRILL SAMPLING (2006 – 2023)

The sampling protocol adopted by Hecla during its ownership period from 2022 remained relatively unchanged from the surface and underground drill programs conducted by Alexco between 2006 and 2021.

Core logging and sampling were completed by Hecla staff, where a logging geologist marked the sample intervals and cutting orientation normal to veins on the core. After logging, the core was digitally photographed. Where possible, the surface core was sawn in half lengthwise using a diamond saw, whereas the broken core was manually split in half. One half of the core was returned to the core box for storage at the site while the other was placed in a thick-walled plastic bag for shipment.

At the Bellekeno project during operational periods some core was whole core sampled, and recently at Bermingham some underground resource definition drilling was whole core sampled to obtain an increased sample mass in the high-grade silver mineralization. No further on-site processing was undertaken.

Samples are a maximum of 2 m long within unmineralized major rock types but are broken at lithological contacts and significant mineralization changes. Intervals with no recovery due to core loss are recorded separately. Sample intervals within mineralized zones range from 0.10 m to 1.0 m, based on consistency of mineralization. In initial work at the prospects, drill holes were sampled top to bottom; however, once a considerable body of geochemical data was available and the nature and distribution of the mineralization better understood, some intervals of barren material were not sampled particularly in close proximity to adjacent drill holes that had been sampled continuously.

Some minor modification in the sample shipment procedure has occurred over time, primarily in response to changing laboratory locations and the logistics surrounding available commercial transport. In all cases, approximately four to five individual samples are placed in polyfiber bags for shipment.

In 2006, samples were sent to Whitehorse, Yukon by Kluane Transport then by Manitoulin Transport to the ALS Chemex facility in North Vancouver, British Columbia for preparation and analysis. Beginning in 2007, each shipping bag was sealed with a numbered security tag, before being placed on pallets and shrink-wrapped for shipping.

In 2007/2008, samples were transported to the Canadian Freightways facility in Whitehorse, Yukon by Alexco personnel. Canadian Freightways then trucked the samples to the ALS Chemex facility in Terrace, British Columbia for preparation. Pulverized subsample splits were then sent to the ALS Chemex facility in North Vancouver, British Columbia for analysis.

In 2009, samples were transported to the Eco Tech Labs preparation facility in Whitehorse, Yukon by Alexco personnel. Pulverized subsample splits were then sent to the Eco Tech facility in Kamloops, British Columbia for analysis.

In 2010, samples were shipped via Manitoulin Transport to Whitehorse, Yukon where they were couriered to the preparation facilities of either AGAT or ALS Minerals in Whitehorse. The pulverized subsample splits were then sent to the AGAT facility in Mississauga, Ontario, or the ALS facility in North Vancouver, British Columbia, for analysis.

Between 2011 and 2013, samples were shipped via Manitoulin Transport to Whitehorse, Yukon where they were delivered directly to the preparation facilities of ALS Minerals in Whitehorse. The pulverized subsample splits were then sent under seal by the laboratory to the ALS facility in North Vancouver, British Columbia, for analysis.

From 2014 to 2021, samples have been shipped in sealed wooden boxes containing approximately 100 samples, directly by company representatives to the ALS Minerals sample preparation facility in Whitehorse and the assay pulp is transported under seal by the laboratory to the North Vancouver analytical facility.

Since 2021 shipping of samples is conducted in batches of 20, inclusive of QA/QC samples. These samples are placed in pre-numbered rice bags, sealed using a cable tie, and their contents are recorded on a batch sample sheet. These samples are then transported to the ALS Minerals sample preparation facility in Whitehorse and the assay pulp is transported under seal by the laboratory to the North Vancouver analytical facility.

8.1.4 UNDERGROUND SAMPLING

Neither the historical underground face samples nor those conducted by Alexco and Hecla have been incorporated into the estimation process. This decision stems from the observed potential positive bias in the underground samples compared with core samples. Possible contributing factors include the utilization of a non-certified on-site laboratory or the physical properties of higher-grade zones, which may introduce oversampling. Only at Bellekeno were the underground samples included in the estimate, as this was subjected to a more thorough review by Alexco as part of the 2009 updated PEA. The estimated Mineral Resources conducted by SRK in 2013 applied factoring to the face samples to mitigate potential bias during resource estimation. To date, no substantial changes have occurred at Bellekeno, and therefore, SRK’s resource model has not required updating.

For Onek and Lucky Queen, these samples were utilized in constructing the geological model and variographic modeling. No historical chip data were available for the Flame and Moth and Bermingham deposits.

There is limited information about the historical sampling procedures, and their respective quality control, as part of the validations carried out by Alexco and independent consultants in previous studies. Historic data verification procedures are outlined below.

The verification procedure consisted of cross-checking the assay values in the database to the values on the original scanned historic assay plan maps. The sample interval points, and respective silver assays were imported from the database and overlain on the original maps. All points were visually inspected to ensure that chip sample lines fell within the boundaries of the drift outlines. Then all assay intervals in the database were checked to ensure they matched with what was originally written on the maps.

Historical chip samples were commonly analyzed for silver, lead, and zinc only. Chip samples were generally taken as cuts across the vein and into the hanging wall and footwall rocks. An undated UKHM document outlines underground chip sample procedures as well. In addition to the above information, emphasis is put on clean faces to prevent sample contamination from previous blasting activities. Samples were to be taken within a 1.5 ft (0.5 m) wide area across the rock face. In addition to separate samples per rock type, this undated document requires separate samples for a change in structure. The sample location was to be measured from the nearest survey station; the resulting distance measurement was used to plot the samples and assay results on level plans. More detailed information was listed regarding the direction in which samples were to be taken for various kinds of underground openings.

The underground face samples by Alexco and Hecla were collected regularly, occurring at each heading advance with a frequency ranging from 1.5 m to 3 m, depending on the length of the mining advance. This involved using a hammer and chisel with the channel chip sampling method. The samples were collected between the hanging wall and footwall contacts of mineralized zones, with common lengths being 1.0 and 1.5 meters. Prior to mapping and sampling, all faces are washed and cleaned of loose material. Sample intervals are painted on the face and numbered consecutively from the left rib to the

right rib. Standard reference materials are added to the sample stream and duplicate assays are performed in regular intervals by the mine laboratory.

8.2 LABORATORIES PROCEDURES

Details regarding the laboratory procedures for historical samples are unavailable. All descriptions in the section below pertain to samples conducted by Alexco and Hecla up to the current date.

Laboratory procedures have been consistent for the 2006–2021 Alexco programs and have been implemented by Hecla. Sample preparation consists of initial fine crushing of the sample to more than 70% passing 2 mm with the crusher cleaned with “barren material” after every sample. A nominal 250 g split of this material is then pulverized to greater than 85% passing 75 microns for analyses with the pulverizer cleaned with “barren material” after every sample. Duplicate samples are prepared at the preparation facility when noted by collecting a second 250 g split from the crushed material.

Samples are analyzed for gold by fire assay and atomic absorption spectrometry on 30 g subsamples and for a suite of 27 to 48 elements by four acid digestion and either inductively coupled plasma atomic emission spectroscopy (ICP-AES) or induced coupled plasma mass spectroscopy (ICP-MS) (on 0.5 g subsamples). Elements exceeding the concentration limits of ICP-AES or ICP-MS are re-assayed by single element four acid digestion and atomic emission spectroscopy. Silver results exceeding ICP-AES limits are re-assayed by fire assay and gravimetric finish on 30 g subsamples. Lead and zinc results exceeding concentration limits are analyzed by volumetric titration.

Crushed reject material and residue assay pulps are annually returned to the Elsa exploration facilities for storage.

The samples have been analyzed mainly by ALS Minerals (approximately 82% of total samples), ALS Minerals, Eco Tech, and AGAT are all accredited to ISO 17025 by the Standards Council of Canada for several specific test procedures, including fire assay for gold and silver with atomic absorption and gravimetric finish; multi-element inductively coupled plasma optical emission spectroscopy; and atomic absorption assays for silver, copper, lead, and zinc. ALS Minerals laboratories also participate in international proficiency tests, such as those managed by CANMET and Geostats.

ALS Minerals, Eco Tech, and AGAT operate as independent certified laboratories around the world or locally, there is no relationship between the laboratories and Hecla, or previous owners, and all procedures and analytical assays have been carried out independently and objectively.

8.3 QUALITY ASSURANCE AND QUALITY CONTROL PROCEDURE (QA/QC)

Alexco implemented quality control procedures for all Keno Hill Silver District drilling campaigns since 2006, and these protocols have been consistently upheld during the recent drilling campaigns conducted by Hecla between 2022 and 2023. Each 20-sample batch sent for assaying includes three control samples: a commercial standard reference material (SRM), a coarse blank, and a field duplicate. The location of control samples in the sample stream is defined by the logging geologist (standard reference material or SRM, blank, and duplicate). Control samples are inserted when the core is sawn or when the whole core is sampled. The quality control program developed by Alexco and Hecla is considered mature and overseen by appropriately qualified geologists. The data collected by Hecla on the Project was acquired using adequate quality control procedures that generally meet or exceed industry best practices for an exploration property at the resource delineation stage.

Throughout various drilling campaigns, the outcomes of quality controls have been monitored, and any associated issues have been thoroughly investigated to facilitate continuous improvement. These findings have been documented in a quality control database, along with graphical representations of quality control results for different periods.

Table 8-1 summarizes the insertion rate of control samples per deposit for all samples in Keno Hill, and Table 8-2 summarizes the insertion rate of control samples per year only for Bellekeno, Bermingham, Flame and Moth, Lucky Queen, and Onek.

Table 8-1 – Control Sample Insertion Percentage by Deposit for Keno Hill (2006 – 2023).

Deposit	Blank	Coarse Duplicate	Pulp Duplicate	SRM	Primary Samples	Total Samples	% QAQC
Bellekeno	914	885	1,207	1,114	12,761	16,881	24%
Bermingham	762	757	152	764	14,830	17,265	14%
Flame and Moth	425	426	178	440	7,109	8,578	17%
Lucky Queen	196	191	272	207	3,170	4,036	21%
Onek	306	290	437	338	4,875	6,246	22%
Subtotal	2,603	2,549	2,246	2,863	42,745	53,006	19%
Subtotal QAQC%	5%	4%	4%	5%	81%	100%	
Other	1,216	1,215	1,015	1,375	25,179	30,000	16%

Table 8-2 - Control Sample Insertion Percentage by Year for Bellekeno, Lucky Queen, Flame and Moth, Onek, and Bermingham.

Year	Blank	Coarse Duplicate	Pulp Duplicate	SRM	Primary Samples	Total Samples	% QAQC
2006	172	161	217	216	2,749	3,515	22%
2007	409	392	496	426	6,603	8,326	21%
2008	202	190	264	209	3,447	4,312	20%
2009	250	236	498	250	3,903	5,137	24%

Year	Blank	Coarse Duplicate	Pulp Duplicate	SRM	Primary Samples	Total Samples	% QAQC
2010	242	243	428	270	4,047	5,230	23%
2011	235	231	343	264	3,821	4,894	22%
2012	329	334	-	458	5,477	6,598	17%
2013	66	67	-	87	1,018	1,238	18%
2014	120	119	-	114	1,928	2,281	15%
2015	39	39	-	40	661	779	15%
2016	117	119	-	116	1,994	2,346	15%
2017	63	65	-	63	1,096	1,287	15%
2018	75	72	-	71	1,272	1,490	15%
2019	25	25	-	25	407	482	16%
2020	28	28	-	28	479	563	15%
2021	121	121	-	120	2,039	2,401	15%
2022	27	28	-	28	463	546	15%
2023	83	79	-	78	1,341	1,581	15%
Total	2,603	2,549	2,246	2,863	42,745	53,006	19%

8.3.1 STANDARD REFERENCE MATERIALS

All Standard Reference Material has been pulverized and inserted as a 50 g to 100 g sample. Throughout the drilling sampling carried out by Alexco, the process originally used one of 16 different standard reference materials purchased from WCM Sales Limited of Burnaby, British Columbia: nine polymetallic copper, lead, zinc, and silver reference materials (PB 111, PB 112, PB 113, PB 116, PB 129, PB 131, PB 137, PB141 and PB 145) and twelve silver reference materials (PM 1107, PM 1108, PM 1116, PM 1117, PM 1123, PM 1127, PM 1128, PM 1129, PM 1130, PM 1132, PM1133 and PM 1141) for inclusion in each 20-sample batch (Table 8-3). Hecla has since added one additional polymetallic copper, lead, zinc, and silver reference material (MP-1b) (Table 8-3).

Table 8-3 - Commercial Standard Reference Material Used for Drilling Programs for the Keno Hill.

SRM	Control inserted	Cu (%)	SD	Pb (%)	SD	Zn (Z)	SD	Ag (g/t)	SD	Ag (oz/t)	SD	Au (g/t)	SD
MP-1b	3	3.07	0.09	2.09	0.07	16.67	0.22	47.00	3.50				
PB 111	76	0.69	0.01	2.12	0.04	0.45	0.02	195.00	5.72				
PB 112	79	0.85	0.01	0.92	0.02	1.27	0.03	222.00	2.00				
PB 113	183	0.47	0.01	1.11	0.02	1.40	0.05	22.00	1.00				
PB116	100	0.43	0.01	1.40	0.06	0.85	0.02	22.00	1.00				
PB 129	261	0.28	0.01	1.24	0.02	2.00	0.06	23.00	1.70				
PB 131	442	0.47	0.01	1.04	0.04	1.89	0.06	262.00	11.00				
PB137	385	0.21	0.01	2.62	0.09	2.69	0.12	111.00	2.00	-	-	-	-
PB141	-	1.02	0.01	6.68	0.15	3.78	0.14	173.00	3.00	-	-	-	-

SRM	Control inserted	Cu (%)	SD	Pb (%)	SD	Zn (Z)	SD	Ag (g/t)	SD	Ag (oz/t)	SD	Au (g/t)	SD
PB145	75	0.19	0.01	1.34	0.05	1.58	0.04	62.00	2.80				
PM1107	416	-	-	-	-	-	-	1194.00	34.00	34.80	1.00	-	-
PM1108	117	-	-	-	-	-	-	658.00	10.00	19.20	0.30	-	-
PM1116	158	-	-	-	-	-	-	769.00	23.00	22.40	0.70	-	-
PM1117	314	-	-	-	-	-	-	386.00	16.00	11.30	0.50	-	-
PM1123	384	0.31	0.01	-	-	-	-	31.00	1.29	-	-	1.42	0.05
PM1127	12							1580.00	36.00				
PM1128	225	-	-	-	-	-	-	592.00	12.00	17.30	0.40	-	-
PM1129	53							34.00	1.70				
PM1130	56							101.00	3.00				
PM1132	-	-	-	-	-	-	-	2287.00	54.33	66.69	1.58	-	-
PM1133	282	-	-	-	-	-	-	757.00	19.00	22.10	0.50	-	-
PM1141	81	1.09	0.05					19	1.29			0.55	0.02

In 2012, Alexco started using a series of certified standard reference materials sourced from the Bellekeno deposit: polymetallic standards (Table 8-4), that were certified by Smee & Associates Consulting Ltd. (Bellekeno-C, Bellekeno-M, Bellekeno-S, Bellekeno-R and Bellekeno-W) that were initially tested as internal laboratory standards at the onsite Bellekeno assay laboratory along with CDN Resource Laboratories Ltd. Standards (ME-4, ME-5). The Bellekeno-derived standards are now commercially available identified as the KHP series below (Table 8-4) and continue to be used routinely with the range of WCM standards.

Table 8-4 - Standard Reference Material Used by Hecla Developed from the Bellekeno Deposit.

SRM	Control inserted	Pb (%)	SD	Zn (%)	SD	Ag (g/t)	SD	Ag (oz/t)	SD
KHP-C	34	14.62	0.58	12.32	0.23	1,162.00	23.50	-	-
KHP-M	84	14.02	0.63	7.85	0.20	971.00	19.00	-	-
KHP-R	11	36.19	2.33	5.08	0.13	2,224.00	47.00	-	-
KHP-S	73	12.47	0.38	13.17	0.41	1,094.00	20.00	-	-
KHP-W	199	3.06	0.06	1.79	0.05	270.00	10.00	-	-
ME-4	23	4.25	0.12	1.10	0.03	402.00	12.50	-	-
ME-5	5	2.13	0.06	0.58	0.01	206.10	6.55	-	-

Figure 8-1, Figure 8-2, and Figure 8-3 show the results for silver across three certified standard reference materials since 2006 encompassing the latest period for all deposits, to see the trend along different periods. These stand as illustrative examples of the SRM data stored in the database. No significant biases are noted in the standards with minor errors associated with the standard coding issues.

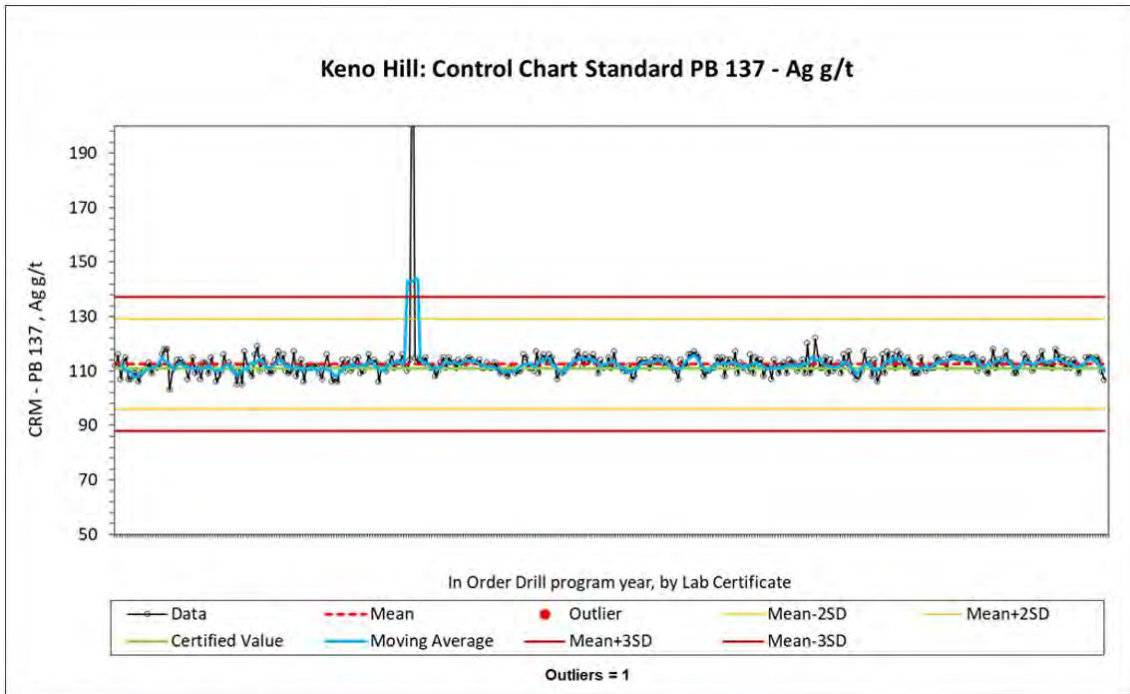

Figure 8-1 – Combined Control Chart for Standard PB 137 Showing Results for Silver at Keno Hill Deposits.

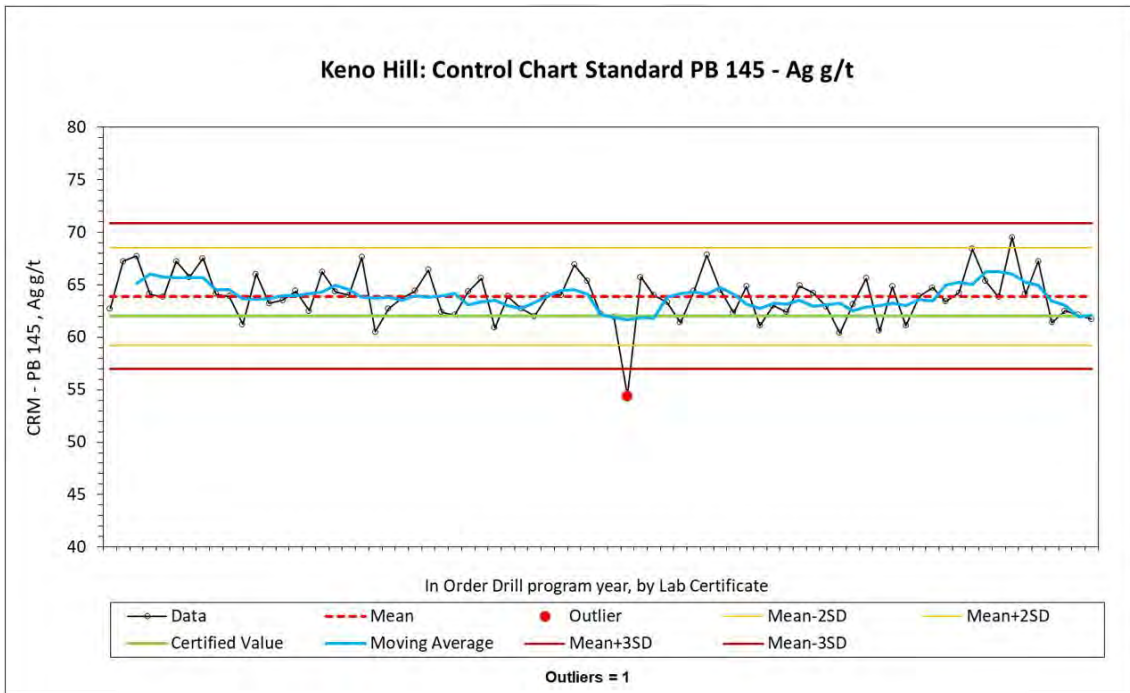

Figure 8-2 - Combined Control Chart for Standard PB 145 Showing Results for Silver at Keno Hill Deposits.

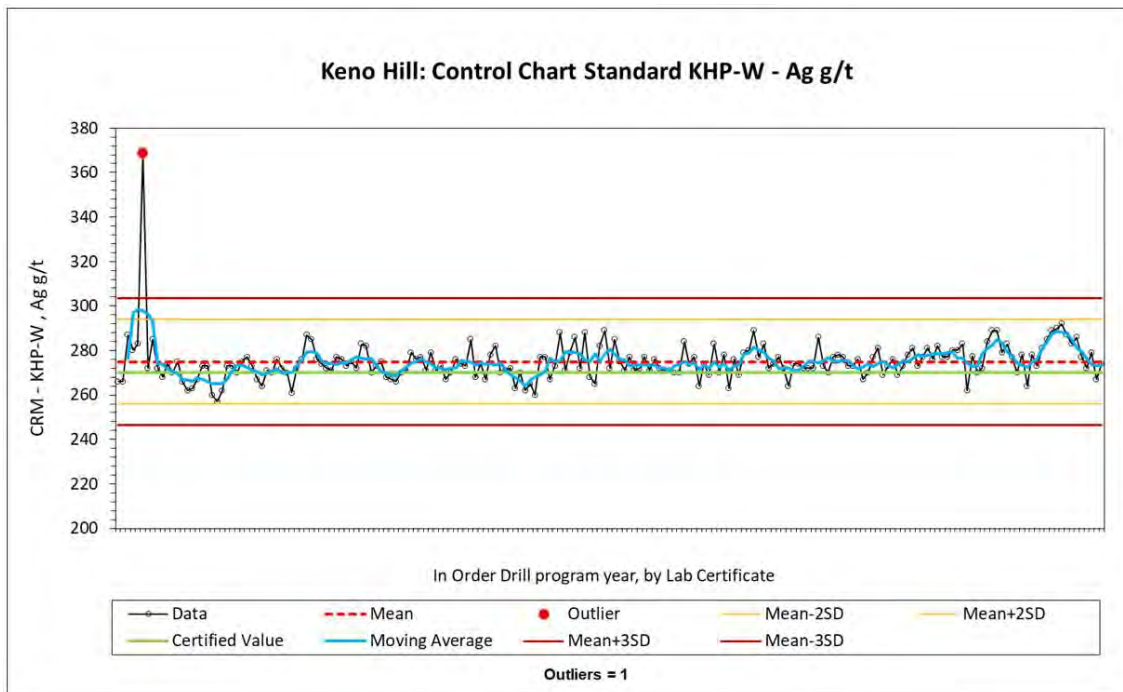

Figure 8-3 - Combined Control Chart for Standard PB 145 Showing Results for silver at Keno Hill Deposits.

8.3.2 COARSE BLANK SAMPLES

Since 2006, the assessment of coarse blanks has been implemented to gauge the potential contamination risk within the laboratory during the sample comminution process. The coarse blank is commercially purchased “landscape rock,” either dolomite or basalt with approximately 0.35 kg to 1.5 kg of this material inserted. Table 8-5 provides a summary of the compiled coarse blank results for Bellekeno, Bermingham, Flame and Moth, Lucky Queen, and Onek. Additionally, Figure 8-4 illustrates the compiled silver results organized by drill campaign and certificate.

To assess sample contamination, a criterion of 5 times the detection limit has been employed. Notably, there are various detection limits, particularly for lead and zinc, and a threshold of 10 ppm has been adopted for both, based on observations from the database. No significant contamination issues were detected for gold, silver, and lead; however, inconsistencies above 10% (failures) have been noted for zinc, with the majority falling below 0.05 %; consequently, zinc is not deemed a pertinent contamination concern.

Table 8-5 – Compiled Results from Blank Sample Analysis for Bellekeno, Bermingham, Flame and Moth, Lucky Queen, and Onek.

Element	Total	Min	Max	D. Limit	Failures	% Failures
Au (g/t)	3,717	0.002	5,555	0.01	39	1%
Ag (g/t)	3,734	0	1,000	0.5	94	3%
Pb (ppm)	3,735	0.0005	2,770	10	160	4%
Zn (ppm)	3,737	0.0005	2,770	10	591	16%

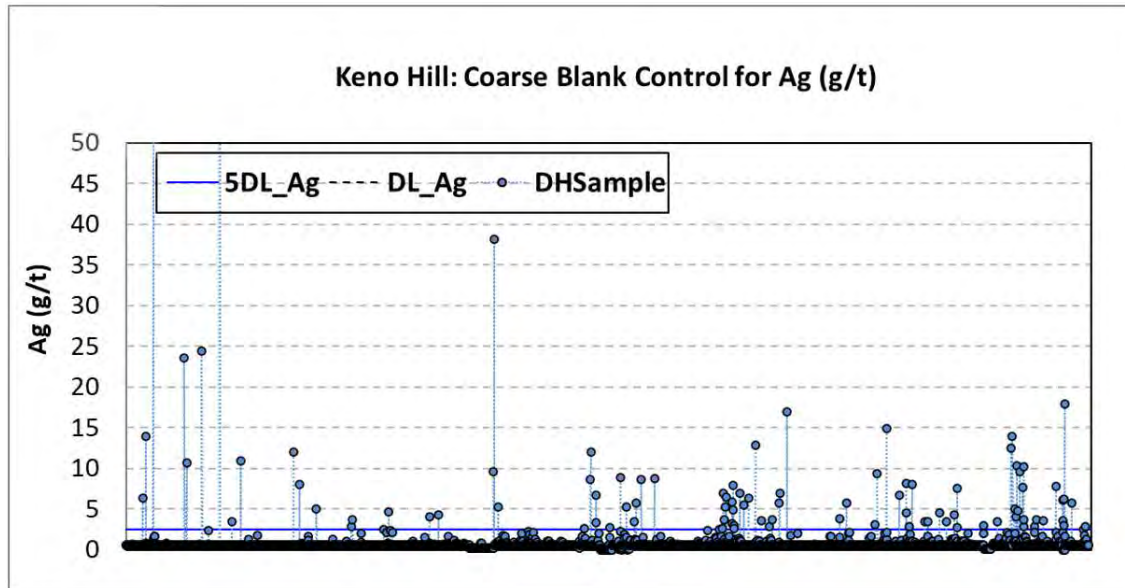

Figure 8-4 – Compiled Blank Control Samples of Silver for Bellekeno, Bermingham, Flame and Moth, Lucky Queen, and Onek.

8.3.3 COARSE DUPLICATES

The objective of the coarse duplicates is to estimate the precision during the comminution process. For precision control, an empty sample bag is inserted at the location of the duplicate, which is subsequently collected during sample preparation at the laboratory prep facility. The duplicate consists of a coarse reject split from the preceding sample.

Precision has been evaluated with the hyperbolic method, with a relative acceptance error of 20% for coarse duplicates. Table 8-6 provides a summary of the compiled coarse duplicate results for Bellekeno, Bermingham, Flame and Moth, Lucky Queen, and Onek. Additionally, Figure 8-5 illustrates the compiled

silver results. There have been no observed issues with precision during the laboratory sample comminution stage.

Table 8-6 – Compiled Results from Coarse Duplicate Analysis for Bellekeno, Bermingham, Flame and Moth, Lucky Queen, and Onek.

Element	Detection Limit	Total Samples	Number Failures	Failure Rate
Au (g/t)	0.002	2487	83	3.3%
Ag (g/t)	0.05	2522	33	1.3%
Pb (%)	0.0001	2522	41	1.6%
Zn (%)	0.0003	2522	22	0.9%

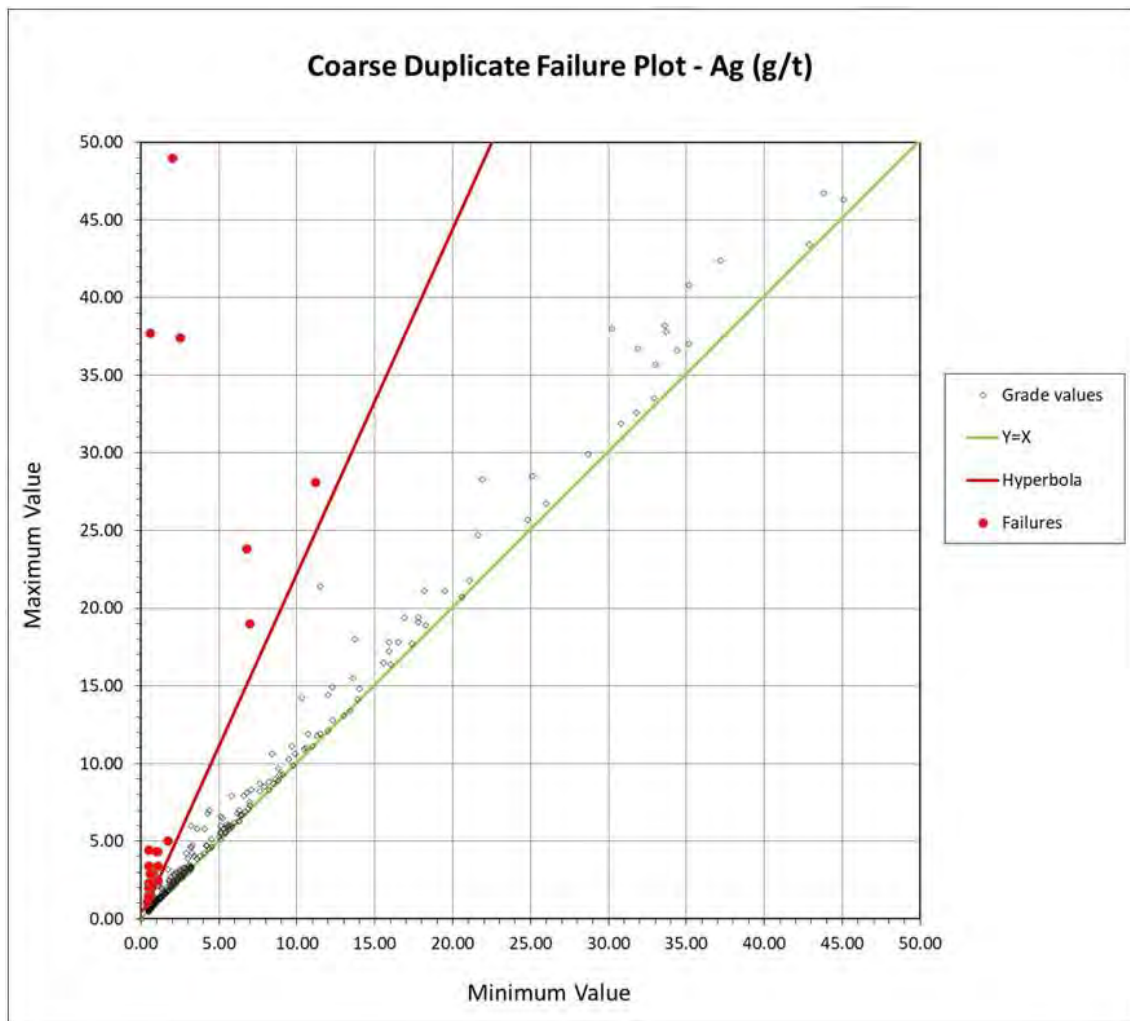

Figure 8-5 – Compiled Coarse Duplicate Control Samples of Silver for Bellekeno, Bermingham, Flame and Moth, Lucky Queen, and Onek.

8.3.1 PULP DUPLICATES

Between 2006 and 2011 duplicate pulps were included in the QA/QC controls. The objective of the pulp duplicates is to estimate the precision during the pulverization process. Similar to the coarse duplicates, an empty sample bag was inserted at the location of the duplicate, the duplicate was formed through a split of the pulp from the preceding sample.

Precision has been evaluated with the hyperbolic method, with a relative acceptance error of 10% for pulp duplicates. Table 8-7 provides a summary of the compiled pulp duplicate results for Bellekeno, Bermingham, Flame and Moth, Lucky Queen, and Onek. Additionally, Figure 8-6 illustrates the compiled silver results. Inconsistencies beyond the accepted range (10%) exist; however, these have been primarily attributed to over-limit values that have not undergone reanalysis; hence, no significant precision issues have been acknowledged.

Table 8-7 - Compiled Results from Pulp Duplicate Analysis for Bellekeno, Bermingham, Flame and Moth, Lucky Queen and Onek.

Element	Detection Limit	Total samples	Number Failures	Failure Rate
Au (g/t)	0.002	1044	133	12.7%
Ag (g/t)	0.1	947	150	15.8%
Pb (%)	0.0001	941	157	16.7%
Zn (%)	0.0005	956	116	12.1%

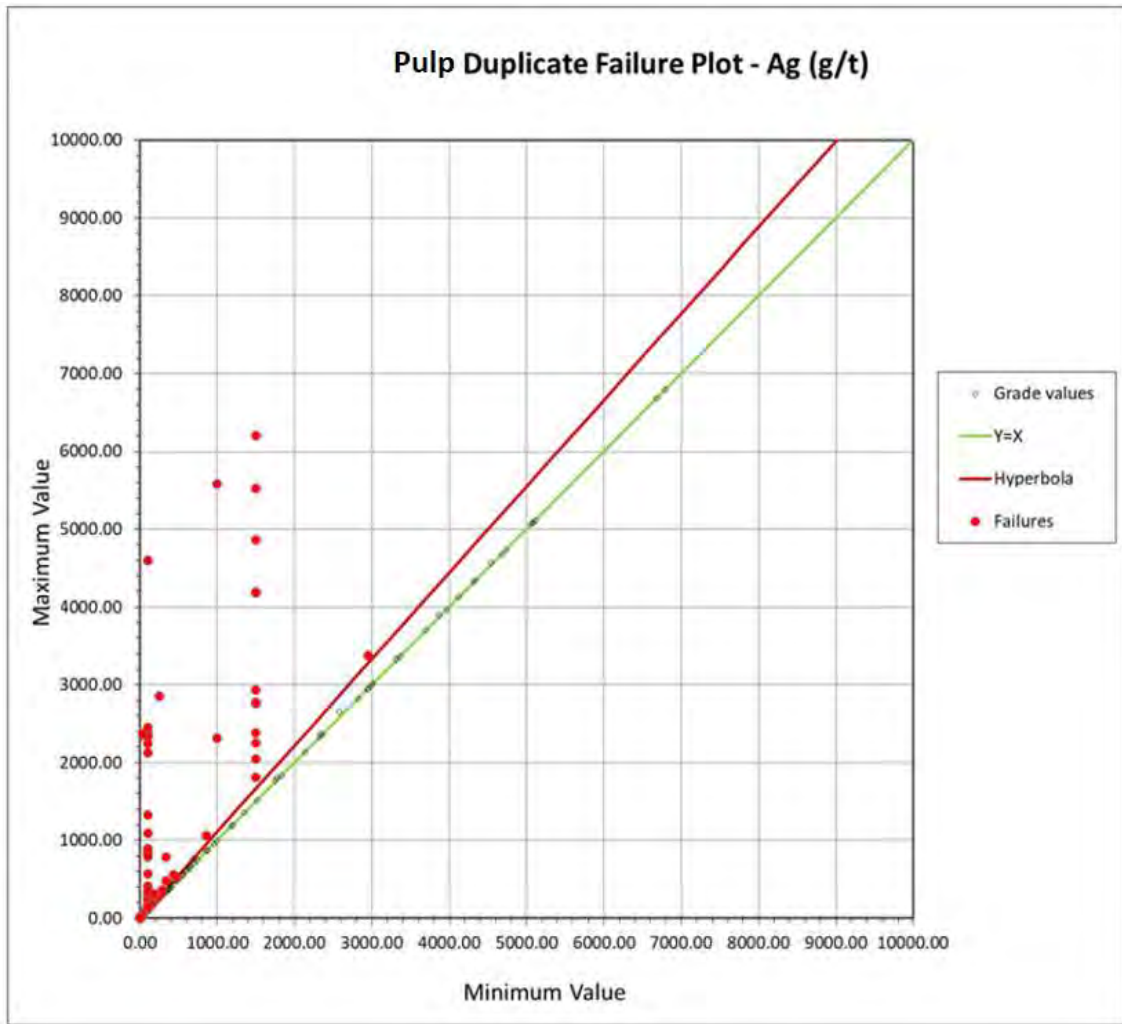

Figure 8-6 - Compiled Pulp Duplicate Control Samples of Silver for Bellekeno, Bermingham, Flame and Moth, Lucky Queen and Onek.

8.3.2 UMPIRE LABORATORY DUPLICATES

As part of the Keno Hill Mine due diligence in 2022, Hecla conducted a sample analysis using the external laboratory services of Bureau Veritas (BV) in Canada as a secondary laboratory. This involved an interlaboratory test, also referred to as an umpire laboratory, to independently validate the precision and accuracy of the chemical analyses conducted by the primary laboratory (ALS).

The analysis covered various drilling campaigns spanning the years 2008 to 2021, with a primary focus on the Bermingham area. Additionally, there were minor analyses conducted in the Flame and Moth, as well as Lucky Queen areas.

Table 8-8 provides a summary of the umpire laboratory duplicate results. The comparison reveals no noteworthy distinctions between the primary and secondary laboratories, thereby affirming the results

obtained by Alexco. It should be noted that the difference observed in the lead results is a consequence of a limited number of analyses.

Table 8-8 – Umpire Lab Duplicates Analysis for Bermingham, Flame and Moth, and Lucky Queen (Hecla, 2022c).

Grade Variable	Laboratory	Total samples	Mean	Mean % diff.
Ag (g/t)	ALS	268	2,388.2	-1.0%
	BV	268	2,357.4	
Pb (%)	ALS	271	6.11	7.0%
	BV	271	6.55	
Zn (%)	ALS	271	3.61	2.0%
	BV	271	3.67	

8.4 SAMPLE SHIPMENT AND SECURITY

Some minor modification in the sample shipment procedure has occurred over time, primarily in response to changing laboratory locations and the logistics surrounding available commercial transport. In all cases, approximately four to five individual samples are placed in polyfiber bags for shipment.

In 2006, samples were sent to Whitehorse, Yukon by Kluane Transport then by Manitoulin Transport to the ALS Chemex facility in North Vancouver, British Columbia for preparation and analysis. Beginning in 2007, each shipping bag was sealed with a numbered security tag, before being placed on pallets and shrink-wrapped for shipping.

In 2007/2008, samples were transported to the Canadian Freightways facility in Whitehorse, Yukon by Alexco personnel. Canadian Freightways then trucked the samples to the ALS Chemex facility in Terrace, British Columbia for preparation. Pulverized subsample splits were then sent to the ALS Chemex facility in North Vancouver, British Columbia for analysis.

In 2009, samples were transported to the Eco Tech Labs preparation facility in Whitehorse, Yukon by Alexco personnel. Pulverized subsample splits were then sent to the Eco Tech facility in Kamloops, British Columbia for analysis.

In 2010, samples were shipped via Manitoulin Transport to Whitehorse, Yukon where they were couriered to the preparation facilities of either AGAT or ALS Minerals in Whitehorse. The pulverized subsample splits were then sent to the AGAT facility in Mississauga, Ontario, or the ALS facility in North Vancouver, British Columbia, for analysis.

Between 2011 and 2013, samples were shipped via Manitoulin Transport to Whitehorse, Yukon where they were delivered directly to the preparation facilities of ALS Minerals in Whitehorse. The pulverized subsample splits were then sent under seal by the laboratory to the ALS facility in North Vancouver, British Columbia, for analysis.

Between 2014 and 2021, Alexco samples have been shipped in sealed wooden boxes containing approximately 100 samples. Since 2021, approximately 20 samples have been placed into a labeled rice bag and shipped directly to the ALS Minerals sample preparation facility in Whitehorse with the assay pulp transported under seal by the laboratory to the North Vancouver analytical facility.

8.5 SPECIFIC GRAVITY MEASUREMENTS

At Keno Hill, specific gravity measurements are systematically acquired for both mineralized and non-mineralized material through on-site procedures using a water immersion method. The process initially involves determining a correction factor. This is achieved by submerging an empty tray into the water, setting the balance to zero, and subsequently removing the tray from the water. The resulting scale reading, following complete drainage of water from the tray, serves as the designated correction factor. Following this, both dry and wet weights for each sample are recorded, accomplished by positioning a scale above a water-filled bucket. Prior to measurements, a correction factor is meticulously determined.

After every 20 samples, a reference standard of known specific gravity is inserted as a quality control standard. A selection of four standards is used in rotation.

8.6 QP OPINION

It is the opinion of the Mining Plus geology QP, that the Alexco and Hecla drilling and sampling procedures used at Keno Hill are reasonable and adequate for the purposes of estimation of Mineral Resources. The Mining Plus geology QP does not know of any drilling, sampling, or recovery factors related to the Alexco and Hecla drilling that would materially impact the accuracy and reliability of results that are included in the database used for Mineral Resource estimation.

9. DATA VERIFICATION

9.1 SITE VISITS

The Mining Plus geology QP conducted a site visit to the Keno Hill Mine. In total, the Mining Plus geology QP spent two and a half days at the site between October 23 and 28, 2023. Time on site was spent verifying the nature and extent of all exploratory work completed by Hecla. This included field-checking of key drill collar coordinates and visiting geology exposures at mineralized outcrops and underground development and production headings. The verification process also involved confirming mineralized and non-mineralized core intercepts, reviewing standard operating procedures, and undertaking a review of mineral resource estimation processes. Additionally, inspections of both surface and underground drill rigs were undertaken during this site visit. Hecla provided a representative with information related to these activities during the site visit.

9.2 DRILLING DATABASE

The Mining Plus geology QP reviewed Keno Hill's drill hole database (source in Excel files) executed between 2006 and 2023 by Alexco and Hecla. The drilling database review focused on detecting potential errors in holes used in the Mineral Resource Estimate as follows:

- Search for duplicate collar ID.
- Search for duplicate sample numbers.
- Search for maximum grades.
- Search for maximum sample length.
- Review collar location against the surface (underground and superficial).
- Results of the QA/QC program.
- Cross-check the assay result with the lab certificate (approximately 10% of the samples).

Minor inconsistencies were detected in the database, these inconsistencies are not regarded as relevant for the estimation process, with the majority being minor. Inconsistencies were noted in the Onek database, and to a lesser extent Bellekeno and Lucky Queen when compared to their certificates. It has been concluded that the discrepancies between the database and the certificate may be due to other certificates in some cases or incorrect assignments that must be investigated as the reason for the difference is not conclusive. However, correlation comparisons show random variation and most of them have minimal differences. The inconsistencies for Birmingham, and Flame and Moth are less than 1%.

9.3 VERIFICATION OF ANALYTICAL QUALITY CONTROL

Mining Plus completed an independent review of the Quality Control and Quality Assurance (QA/QC) measures and procedures that Hecla has in place to assess the performance of external assay analysis. A compilation of quality control records for drilling relevant to the Bellekeno, Flame and Moth, Birmingham, Lucky Queen, and Onek deposits was prepared based on drilling records provided by Hecla from its corporate database. The data file was sorted into the various types of quality control samples including Blanks, Reference Standards, and Duplicate Samples from both coarse residue and duplicate assays as provided by the laboratory.

Hecla uses a GeoSpark® Software (SQL-based) relational database to store all drilling-related records with drilling records selected as required from the database using appropriate queries and filters.

The company has access to a range of certified reference standards from commercial organizations with some of these prepared from in-situ Bellekeno mineralization which further improves their application in the testing of assay quality control.

Mining Plus considers that the number and percentage of quality control samples included with each sample batch is an appropriate number for analytical quality assessment.

The balance of additional quality control samples added to each batch of drilling samples is considered appropriate for testing different parts of the laboratory analysis process and confirms the veracity of element results.

The Mining Plus geology QP notes the following regarding the QA/QC results of the drilling campaign 2006- 2023:

- Overall, the results of the QA/QC program carried out between 2006-2023 are acceptable, where no significant contamination is observed, with acceptable precision and accuracy without evidence of bias, and are suitable for use in estimating resources.
- QA/QC failures are not adequately investigated and documented; instead, they undergo reanalysis, and if the failure persists, the sampling batch is reanalyzed. However, it is essential to investigate the origin of the error to implement timely corrective measures. Similarly, pulp duplication has been discontinued in the QA/QC process since 2011.
- Incorporating field duplicates, pulp duplicates, and umpire check samples is essential within the QA/QC protocol to assess the precision of samples at various stages of sampling and comminution.
- Fine blank controls must be included to evaluate contamination during the analysis stage.

9.3.1 PREVIOUS REVIEWERS OF QA/QC

From 2010 to 2021, Gilles Arseneau, Ph.D., P. Geo. of SRK Canada, acted as the QP in various previous studies, including the preparation of the 2021 Alexco Technical Report (NI 43-101 Technical Report on Updated Mineral Resource and Reserve Estimate of the Keno Hill Silver District). Throughout this period, Dr. Arseneau conducted diverse reviews of databases and quality control. The results of these reviews are summarized in Sections 9.3.1.1-9.3.1.3.

9.3.1.1 Lucky Queen

In the 2021 Alexco Technical Report, Gilles Arseneau, Ph.D., P. Geo. of SRK Canada, reviewed and verified Lucky Queen drill hole data and quality control assay data from 2006 to 2010. Dr. Arseneau considered the data reliable for resource estimation purposes. The analysis included aggregation of assay results for external quality control samples and duplicate assay pairs. Blank samples exhibited reasonably good performance, with no systematic failures noted for silver, lead, or zinc. However, 6% of gold assay blanks returned a grade higher than 0.01 g/t Au. Commercial standard reference samples and duplicate analyses also showed satisfactory results, supporting the reliability of the analytical data for mineral resource estimation.

9.3.1.2 Onek

In November 2010, June 2011, and August 2014, Dr. Arseneau conducted audits of analytical and quality control data for the Onek deposit. Dr. Arseneau conducted routine verifications to ensure the reliability of the electronic drillhole database, matching assay values against laboratory certificates. While minor issues were resolved, the overall review suggested that silver, gold, lead, and zinc grades could be reasonably reproduced, making the final assay results reliable for resource estimation. After the review, Dr. Arseneau was of the opinion that the Onek drilling database is sufficiently reliable for resource estimation.

9.3.1.3 Bermingham

In 2018, the QP for the 2021 Alexco Technical Report, Gilles Arseneau, Ph.D., P. Geo. of SRK Canada, completed an audit of the Alexco analytical and quality control data acquired during the sampling of the Bermingham deposit; this audit consisted of routine verifications to ascertain the reliability of the electronic drill hole database provided by Alexco. All assays in the current database were verified against independently sourced sample certificates from ALS Chemex, Echo-Tech, and AGAT laboratories. The silver, lead, zinc, and gold values in the assay table were found to match the laboratory certificates with a

few exceptions where samples had been re-assayed, and the database had not been updated with the re-assay certificate number. Alexco corrected this and the sample values were found to match the re-assay certificates. After the review, Dr. Arseneau was of the opinion that the drilling database was sufficiently reliable for resource estimation.

There are no details about the revision done for Flame and Moth and Bellekeno.

9.4 QP OPINION

After evaluating the QA/QC performance for the reporting period of 2022-2023 and examining the QA/QC database along with Dr. Arseneau's previous conclusions in 2021, The Mining Plus geology QP is content with the findings. She is confident that the chemical assays of gold, silver, lead, or zinc do not present any notable issues of accuracy, precision, or contamination. Consequently, their incorporation in resource estimation is considered acceptable.

10. MINERAL PROCESSING AND METALLURGICAL TESTING

10.1 INITIAL CHARACTERIZATION AND SCOPING STUDIES

The metallurgical response of Keno Hill mineralization is well understood through test work and operational experience. Previous test work on the varied mineralization at the property can be traced back prior to 1996 until 2017 as indicated from the multiple studies by Rescan (1996), Wardrop (2009), SRK (2013/2014), and RPA (2017). The Bellekeno deposit was widely investigated between 1996 and 2009 with the test results compiled to form the basis for the design and construction of Keno Hill District Mill in 2010. From 2011 to 2013, samples from deposits of Lucky Queen and Flame and Moth were tested to assess their flotation performance. Since 2018, additional metallurgical test work has been conducted on samples from these deposits and from the Birmingham mineralization area to support the mine plan. Table 10-1 lists the test work assessed herein.

Table 10-1 – Metallurgical Test Work Programs – 1996 to 2019.

Year	Laboratory/ Simulation Report	Samples Domain	Hardness	Mineralogy	Rougher/ Cleaner Flotation	Locked Cycle Flotation	Other Tests
1996	PRA	Blended BK/SK (85%/15%)	✓				✓
2008	SGS – Lead, Zinc and Silver Flotation Testing on Bellekeno Samples	BK	✓	✓			
2009	Inspectorate (PRA)	BK, East/Southwest Zones of BK, OK	✓	✓			✓
2011	Inspectorate (PRA)*	LQ and OK			✓		
2013	Inspectorate (PRA)*	F&M			✓		
2013	Starkey & Associates (S&A) – Bellekeno Grinding Circuit Comminution Throughput Analysis Report	Grinding circuit survey of Keno Hill District Mill	✓				
2018	SGS – The Flotation of Samples from the Birmingham Deposit	BM		✓	✓	✓	
2018	SGS – The Comminution and Flotation of Samples from the Lucky Queen and Flame and Moth Deposits	LQ, F&M (combined Christal and Lightning Zones), F&M (Christal Zone), F&M (Lightning Zone), BM-F&M (Christal Zone), and BM-F&M (Lightning Zone)	✓		✓	✓	
2019	SGS - The Flotation of Samples from the Birmingham and Christal Zone Deposits	Blended F&M (Christal Zone)/BM (70%/30%)			✓	✓	
2019	SGS – The Flotation of Samples from the Birmingham and Christal Zone Deposits (Appendix B)	F&M and LQ		✓			

*Results provided to Tetra Tech in Excel sheet as a compilation of results.

Abbreviations as follows: BK – Bellekeno, LQ – Lucky Queen, F&M – Flame and Moth, OK – Onek, BM – Birmingham, SK – Silver King.

The Flame and Moth metallurgical sampling programs from Lightning Zone and Christal Zone are representative of their respective geological rock type domain. The samples used for composites were collected from exploration drilling programs. The samples for each of the composites were spatially distributed throughout each of the deposits and contained head grades consistent with typical ranges observed in the exploration programs.

The initial metallurgical composites for Birmingham and Lucky Queen were each prepared from samples from exploration drill holes throughout the deposit representing high-grade domains. These were used for testing completed prior to 2018, including both batch and locked cycle testing as reported in the PEA (RPA, 2017).

In 2018, two drill holes were completed in each of the two zones of Flame and Moth (four holes totaling 60 m of drilling) specifically to provide fresh unoxidized material for metallurgical testing on composites representative of each of the Lightning and Christal zones. These composites were then combined with Birmingham composites to test the locked cycle metallurgical response to the flowsheet. Two Birmingham composites were used: the master composite in 2017 from previous test work and a second new composite in 2018 with a lower head grade which would be more typical LOM metals content in order to evaluate expected conditions and evaluate fluctuations in plant feed. The Birmingham, Flame and Moth, and Lucky Queen metallurgical testing results to date have contained similar head grades and have behaved metallurgically similar within each respective deposit.

The Flame and Moth composites were prepared from samples collected from the drilled intervals shown in Figure 10-1.

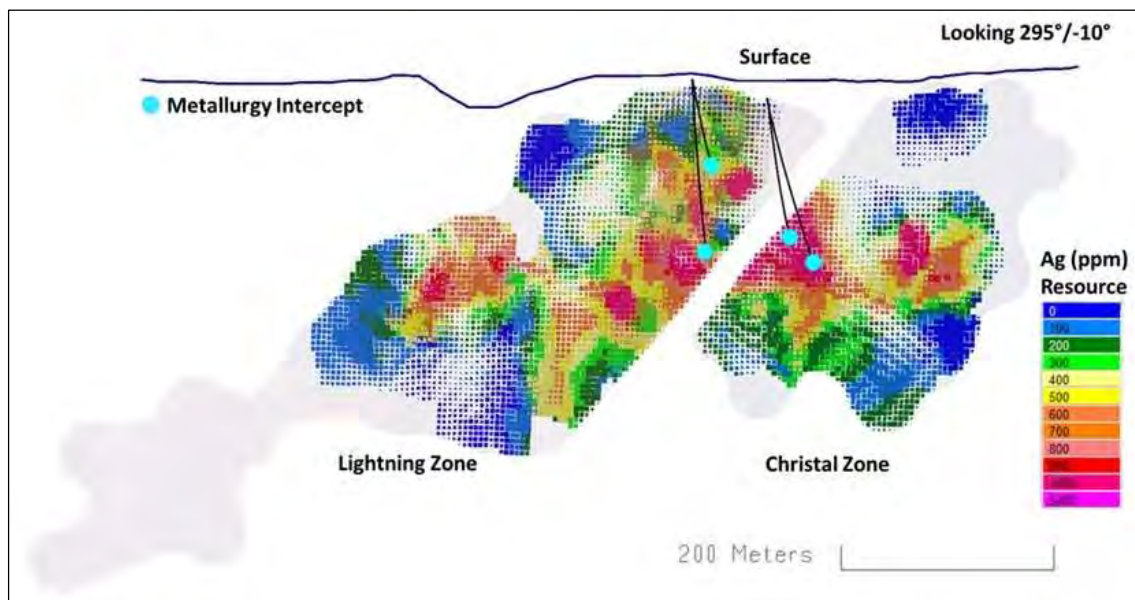

Figure 10-1 – Source Metallurgical Samples from Flame and Moth (Alexco, 2021b).

The assays of each of the composites are shown in Table 10-2.

Table 10-2 – Flame and Moth Composites for Metallurgical Testing (Alexco, 2021b).

Sample	Pb (%)	Zn (%)	Ag (g/t)	Au (g/t)
Lightning Zone Composite	3.16	5.24	749	0.53
Christal Zone Composite	3.56	5.21	857	0.98

The Birmingham Master Composite and New Birmingham Composite were prepared from samples collected from the drilled intervals shown in Figure 10-2.

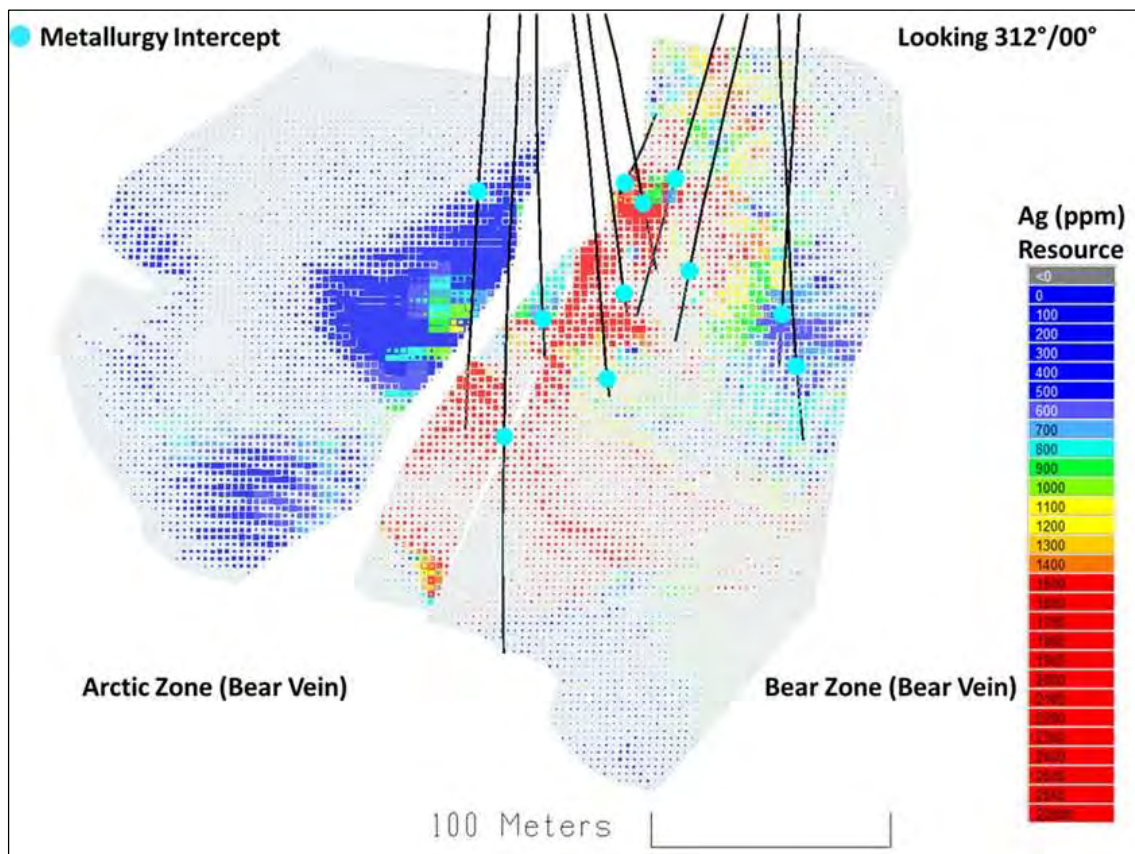

Figure 10-2 – Source of Metallurgical Samples from Birmingham (Alexco, 2021b).

The assayed characteristics of each of the two composites are shown in Table 10-3.

Table 10-3 – Bermingham Composites for Metallurgical Testing (Alexco, 2021b).

Sample	Pb (%)	Zn (%)	Ag (g/t)	Au (g/t)
Master Composite	6.09	1.77	3,308	0.37
New Composite	3.57	2.95	1,712	-

No new composites were prepared for either the Bellekeno or Lucky Queen test work since the 2017 Preliminary Economic Assessment (RPA, 2017).

10.1.1 COMMINUTION DATA LUCKY QUEEN AND FLAME AND MOTH DEPOSITS

In 2018 Bond Ball Mill Work Index (BWi) testing was performed on the Lightning Zone and Christal Zone composites within the Flame and Moth deposit, and the results are summarized in Table 10-4 and Figure 10-3.

Table 10-4 – Summary Results of BWi Testing (SGS, 2018b).

Sample Name	Mesh of Grind	F80 (µm)	P80 (µm)	Gram per Revolution	Work Index (kWh/t)	Hardness Percentile	Category	Feed Passing (%)	Bulk Density
Lightning Zone Comp	100	2,058	121	2.57	10.4	13	Soft	18.1	2,357
Christal Zone Comp	100	2,048	125	2.59	10.5	13	Soft	12.9	2,674

The BWi values obtained were consistent at 10.4 and 10.5 kWh/t, respectively, characterizing the composites as soft.

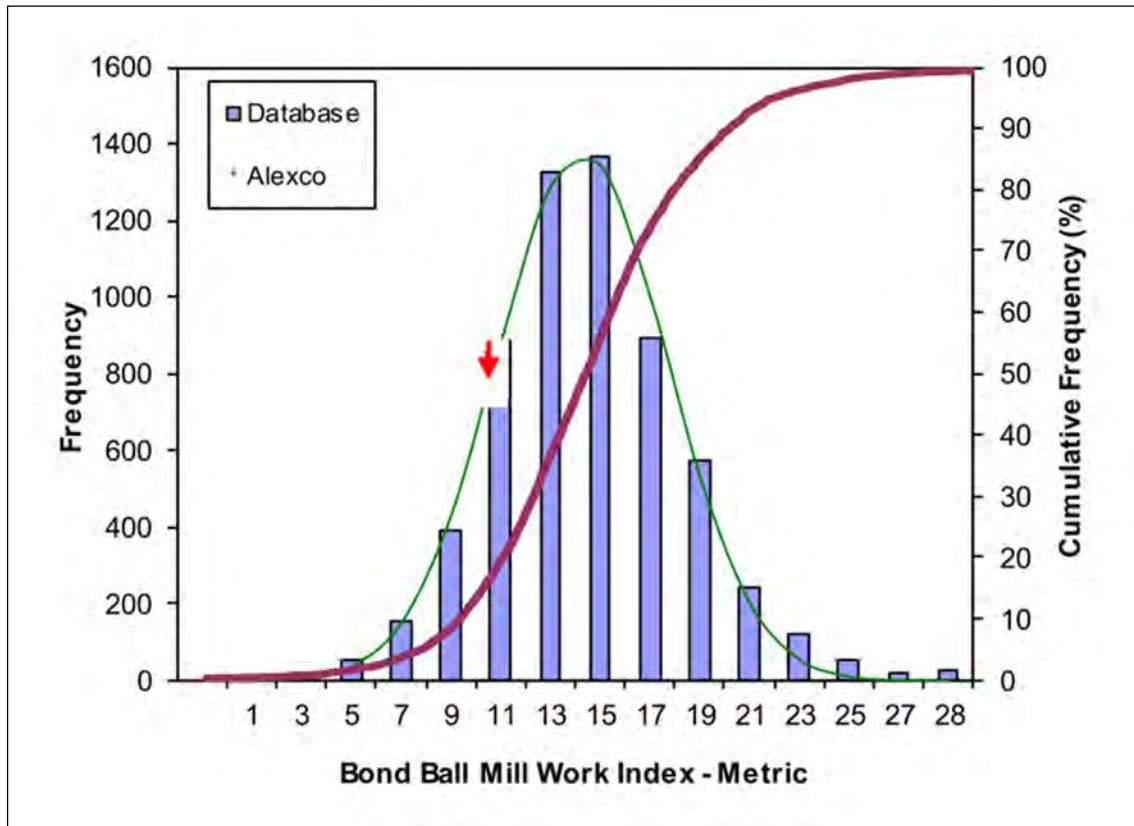

Figure 10-3 – Alexco BWi Results against SGS Database (SGS, 2018b).

10.2 METALLURGICAL LABORATORY TEST-WORK PROGRAM

Values for the initial Bond Rod Mill Work Index (RWi), Bond Ball Mill Work Index (BWi), and Bond Abrasion Index (Ai) were determined for Bellekeno samples during the 1996 and 2009 test programs. The measured RWi on the single Bellekeno composite sample was 8.7 kWh/t, while BWi values on four samples ranged from 7.9 kWh/t to 9.5 kWh/t. This indicated that the Bellekeno samples can be categorized as soft materials with low variability. The abrasion index (Ai) was measured on a single Bellekeno sample with a value of 0.438 g, which was considered moderately abrasive.

In 2013 a benchmark survey on the grinding circuit of Keno Hill District Mill was conducted by Starkey & Associates (S&A) to assess the circuit operation to debottleneck the grinding circuit throughput limitation. Stream samples from the ball mill discharge, pump sump, and ball mill screen oversize and undersize were taken and tested to determine their RWi and BWi values. The RWi was found to be 12.4 kWh/t and the BWi was found to be 10.2 kWh/t. Both results are significantly higher than previous test results from 1996 to 2009. S&A then modeled the grinding circuit operation based on these results, which are summarized in Section 14 of this report.

The specific gravity values for the head samples were determined in 1996 by Inspectorate America Corporation (PRA), which was 3.57 for the Bellekeno sample and 2.81 for the SK sample. PRA completed an additional specific gravity test with the flotation concentrates samples, which was reported to be 6.49 for silver-lead concentrate and 3.95 for zinc concentrate. The 2018 measurement by SGS showed a range between 2.78 and 4.36 for Lightning Zone drill samples and 2.75 and 4.71 for Christal Zone drill samples.

Table 10-5 – Grindability Test Results (Alexco, 2021b).

Test Program	Sample	Bond Ball Mill Work Index (kWh/t)	Bond Rod Mill Work Index (kWh/t)	Abrasion Index (g)	Specific Gravity
1996 PRA	Bellekeno Comp	9.3 **			3.57
	Silver King Comp	10.3**			2.81
2007 SGS	Bellekeno Comp	9.5*			
2008/2009 PRA	Bellekeno Master Comp	-	8.7	0.438	
	Bellekeno East Zone Comp	7.9*			
	Bellekeno SW Zone Comp	8.2*			
2013	Grinding circuit survey of Keno Hill District Mill	10.2	12.4		
2018 SGS	Christal Zone Composite	10.5**			2.75-4.71
	Lightning Zone Composite	10.4**			2.78-4.36

* At a closing mesh size of 106 µm.

** at a closing mesh size of 149 µm.

10.3 MINERALOGICAL ANALYSIS

Mineralogical investigations were conducted in several test programs on different samples. A recent comparison of the results from the Bellekeno, Lucky Queen, Flame and Moth, and Bermingham deposits was made by the previous operator, Alexco, in 2018.

10.3.1 MINERALOGY ANALYSIS ON BELLEKENO SAMPLES

Both SGS and PRA studied the mineralogy characteristics of the Bellekeno mineralization samples in the 2007 and 2009 test programs. In 2007, SGS completed a Quantitative Evaluation of Materials by Scanning Electron Microscopy (QEMSCAN™) analysis that indicated that galena and sphalerite were the principal lead and zinc minerals, respectively. Pyrite accounted for less than 4% of the mass, while trace sulfide minerals included chalcopyrite, bornite, chalcocite, tetrahedrite, and arsenopyrite.

Both the SGS and PRA studies reported on the general coarse texture for the galena and sphalerite minerals, specifically, with the SGS data indicating liberation at a relatively coarse size. At an 80% passing (P80) grind size of 170 µm, 96% of the sphalerite and 95% of the galena particles analyzed were present as liberated phases.

PRA's 2009 tests included a microscopic examination of the composite samples from the Bellekeno Southwest zone and the Bellekeno East zone. The results confirmed galena and sphalerite as the main economic minerals. The Southwest zone composite contained more galena, while the East zone contained predominantly sphalerite. Proustite-pyrargyrite was identified as the only specific silver mineral and was present as small inclusions in galena. Tennantite-tetrahedrite and sphalerite were identified as being additional silver carriers. Native gold was also found as fine inclusions of less than 5 µm in chalcopyrite from the Southwest zone composite sample. In addition, a part of the Bellekeno East zone sample showed the presence of secondary minerals including limonite, covellite, and a minor portion of colloform pyrite that can decompose to sulfide. The PRA study also confirmed the texture of the galena and sphalerite minerals was coarse in general.

10.3.2 MINERALOGY ANALYSIS ON FLAME AND MOTH AND LUCKY QUEEN SAMPLES

In 2017 SGS conducted QEMSCAN examinations on the Flame and Moth and Lucky Queen samples. The mineral distributions are shown in Figure 10-4 for both samples. The minerals of interest contained in the samples included galena at about 3.4% for the Flame and Moth sample and 5.3% for the Lucky Queen sample, sphalerite at 13.0% for the Flame and Moth sample and 1.9% for the Lucky Queen sample, while silver minerals were present at 0.19% for the Flame and Moth sample and 0.22% for the Lucky Queen sample. The major gangue minerals included quartz, Fe-Mn oxides, and pyrite/arsenopyrite for both samples. The Flame and Moth sample contained a much higher pyrite content of 14.5% as compared with the Lucky Queen sample, which had a pyrite content of 1.6%. Similarly, arsenopyrite in the Flame and Moth sample was about 4.4%, which is higher than that of the Lucky Queen sample at a level of 0.2%. About 2.2% and 4.5% sericite/muscovite were identified in the Flame and Moth sample and Lucky Queen sample, respectively. Other gangue minerals such as K-feldspars, dolomite, and rutile were low in content, with each type less than 1%.

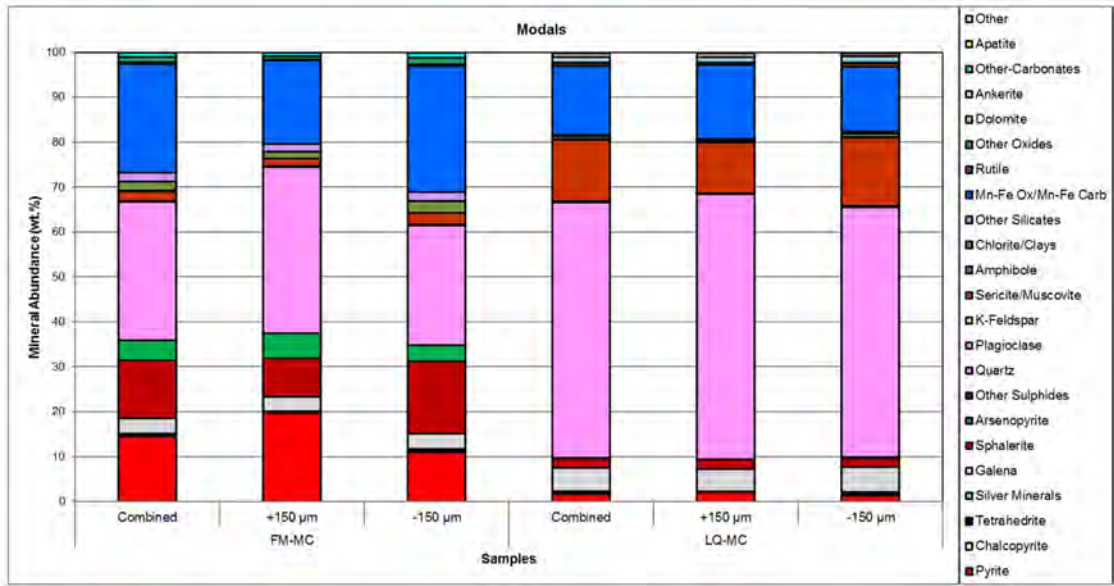

Figure 10-4 – Mineral Abundance of Flame and Moth and Lucky Queen Samples (SGS, 2019).

The liberation and exposure information of galena, sphalerite, pyrite, and silver minerals are summarized in Table 10-6. As compared with the Lucky Queen sample, the Flame and Moth sample showed a lower content of the free and liberated galena, as well as a smaller portion of the exposed rate. In addition, galena in the Flame and Moth sample had a greater association with sphalerite and complex mineralogy, which means more than two mineral types in the grain.

Table 10-6 – Mineral Liberation and Exposure of Flame and Moth and Lucky Queen Samples (Alexco, 2021b).

Minerals*	Lucky Queen Sample						Flame and Moth Sample					
	Association			Exposure			Association			Exposure		
	Free (%)	Liberated (%)	Sphalerite (%)	Complex (%)	100%	20%	Free (%)	Liberated (%)	Sphalerite (%)	Complex (%)	100%	20%
Galena	82.3	10.6	0.5	2.1	87.0	98.7	47.0	19.7	6.2	15.1	53.5	86.3
Sphalerite	84.1	5.0	n/a	3.0	86.0	97.7	61.3	17.5	n/a	10.6	68.9	95.1
Pyrite	58.5	17.3	0.0	14.9	59.3	85.7	71.9	18.4	0.9	5.8	79.7	98.0
Silver Minerals	45.9	10.7	6.7	2.29	53.1	90.7	34.1	13.8	4.2	30.7	45.6	75.3

*Combination of +150µm and -150µm fractions

10.3.3 MINERALOGY ANALYSIS ON BERMINGHAM SAMPLES

In 2018 SGS conducted a QEMSCAN analysis on the Birmingham Master Composite ground to 80% passing 250 µm and screened at 150 µm. Similar observations were made from both the fractions of +150 µm and -150 µm showing that lead was present predominantly as galena and zinc as sphalerite. Silver minerals were also identified from the analyses and examined as a group without specifying the individual silver mineral. The minerals of interest contained in the sample included 6.9% galena, 3.0% sphalerite, and 0.67% silver minerals. The major gangue minerals included 51.2% quartz, 22.3% Fe-Mn oxides, and 8.5% sericite/muscovite, with minor gangue minerals composed of 3.4% pyrite and 1.1% chlorite. Other gangue minerals such as K-feldspars, dolomite, and rutile were low in content with each type less than 1%. Figure 10-5 shows the mineral abundance of the Birmingham sample tested.

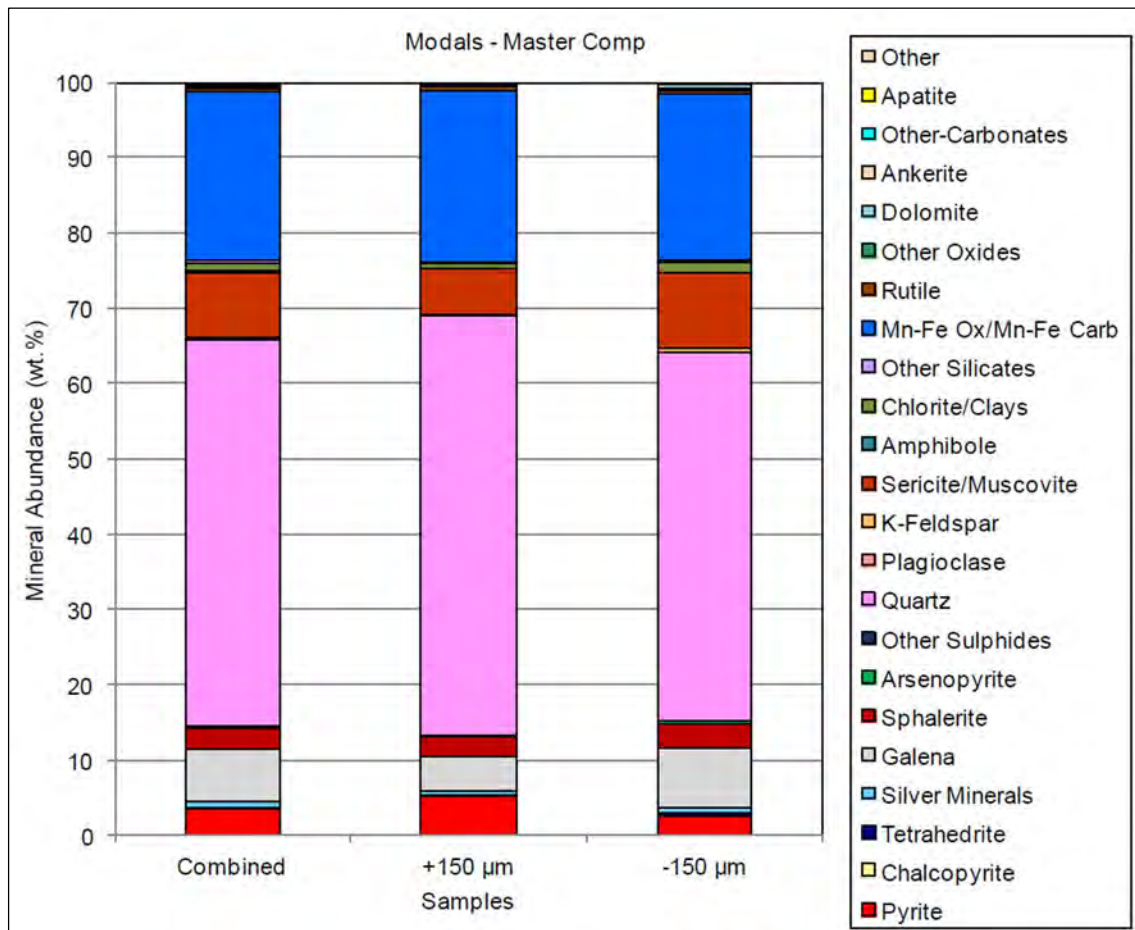

Figure 10-5 – Modal Mineral Abundance of Birmingham Master Composite (SGS, 2018a).

The liberation and exposure information of galena, sphalerite, pyrite, and silver minerals are summarized in Table 10-7. At a grind size of approximately 80% passing 250 µm, high values of free/liberated galena

and sphalerite were observed with high exposure percentages, namely 86% and 95%, respectively, were fully liberated. About 82% of pyrite was found free or liberated and with a low association with galena and sphalerite. Fully exposed pyrite accounts for 75% of the total, with 95% of the pyrite is greater than 20% exposed. Free and liberated silver mineral grains accounted for 65% of the total, while 13% of the silver minerals were found associated with galena, and another 13% of silver minerals were present in complex mineral assemblages. Fully exposed silver mineral grains accounted for 64% of the total and 91% of the silver grains were greater than 20% exposed.

Table 10-7 – Mineral Liberation and Exposure of Bermingham Master Composite (Alexco, 2021b).

Minerals*	Free	Liberated	Complex	Exposure	
	(%)	(%)	(%)	100%	20%
Galena	80.5	11.4	4.2	86.0	97.7
Sphalerite	87.5	9.44	1.49	94.8	98.9
Pyrite	64.1	17.9	9.33	74.5	95.2
Silver Minerals	48.3	16.4	12.8	63.9	91.1

*Combination of + 150 µm and – 150 µm fractions

10.3.4 MINERALOGY ANALYSIS COMPARISON AMONG BELLEKENO, LUCKY QUEEN, FLAME AND MOTH, AND BERMINGHAM SAMPLES

Alexco compared the mineralogical analyses of the samples collected from the Bellekeno, Lucky Queen, Flame and Moth, and Bermingham deposits for the purpose of explaining the inferior metallurgical performance observed on the Flame and Moth samples using QEMSCAN. The conclusions from the QEMSCAN comparison indicated that the Flame and Moth sample had a smaller portion of exposed galena and a greater association of sphalerite and pyrite complex mineralogy. This observation was in line with a much higher ratio of zinc to lead in the Flame and Moth sample as compared with the other deposit samples. The petrographic comparison further indicated that Flame and Moth samples presented a less coarse size of galena, which was more closely intergrown with sphalerite.

10.4 METALLURGICAL RESULTS

10.4.1 FLOTATION TEST WORK OVERVIEW

Rougher, cleaner, and Locked Cycle Flotation Tests (LCT) were initially performed on samples representing the Bellekeno deposit to develop the original process flowsheet used in historical operations. To recommission the mill, similar flotation tests following the same processing philosophy were carried out on individual and blended samples from Lucky Queen, Flame and Moth, and Bermingham deposits. More extensive locked cycle testing was completed on these samples to provide additional data as the basis for

the 2021 Prefeasibility Study (Alexco, 2021b). The locked cycle testing on the composites is outlined in Table 10-8.

Table 10-8 – Locked Cycle Testing Summary (2016-2019) (Alexco, 2021b).

Locked Cycle Test	Sample	Year
LCT1 – 2017	Birmingham Master Composite	2017
LCT2 – 2017	Birmingham Master Composite	2017
LCT1 – 2018	Christal Zone Composite	2018
LCT2 – 2018	Lightning Zone Composite	2018
LCT3 – 2018	30% Birmingham Master Composite – 70% Christal Zone Composite Blend	2018
LCT4 – 2018	30% Birmingham Master Composite - 70% Lightning Zone Composite Blend	2018

10.4.2 BELLEKENO SAMPLES

The batch flotation test work program for Bellekeno samples was completed between 2007 and 2009 and included rougher flotation tests to assess the impacts of primary grind size, reagent schedule, and other test conditions, open cycle cleaner flotation tests to investigate the quality of the cleaner concentrates produced at various conditions, as well as bench-scale locked cycle flotation tests. The major conclusions are summarized as follows:

- Lead and zinc recoveries in the rougher flotation tests were not sensitive to the primary grind size in a P80 size range between 79 µm to 174 µm.
- Regarding the lead rougher concentrate prior to the cleaner flotation stages could improve the zinc rejection in the lead cleaner flotation stage. While for the zinc rougher concentrate regrind tests, only a slight or no improvement on the upgrading of the zinc rougher concentrate was observed.

The locked cycle flotation tests on Bellekeno samples are described in detail in the 2009 Preliminary Economic Assessment report by Wardrop (Wardrop, 2009). Of the five tests, the optimum results were obtained from the LCT1 test reported by PRA in 2008/2009, which was based on the common sequential lead and zinc flotation circuits with a regrinding stage for each circuit. The results are provided in Table 10-9. The anticipated mill recoveries for Bellekeno are based on this test work and the actual results during the previous operation. All five locked cycle tests produced qualified lead and zinc concentrates. High recoveries of silver, lead, and zinc were obtained in the 1996 PRA test and 2008/2009 PRA -LCT1 and LCT 2 tests. SGS test work produced lower recoveries of silver and zinc that may be related to the regrind size and the lack of zinc rougher concentrate regrind. The LCT 3 test program by PRA also produced a low silver recovery that can be attributed to the low silver head grade of the tested sample.

10.4.3 LUCKY QUEEN SAMPLES

The batch flotation tests on Lucky Queen samples were completed in 2013 and 2018. The 2013 tests were performed by the Inspectorate using an open circuit cleaner sequential flotation method with no regrinding stages. The test work results were the best of the four deposits. On average, the lead concentrate contained 68% Pb and 33,960 Ag at a silver recovery of 89% and lead recovery of 91%. The zinc recovery was 73% at a concentrate grade of 59% zinc. Table 10-10 shows the cleaner flotation test results.

The 2018 flotation tests by SGS included five cleaner flotation tests with no regrinding stages. Good silver-lead cleaner concentrates were produced, which contained 15,893 g/t to 18,963 g/t Ag, 50.8% to 58.2% Pb. The zinc cleaner concentrate showed a lower grade, ranging from 30.6% to 41.5% Zn, which may be improved by regrinding the zinc rougher concentrates since the primary grind size was around 90 µm, which was much coarser as compared with other samples reground to 20 µm in cleaner tests. No locked cycle flotation tests have been performed on Lucky Queens samples.

10.4.4 FLAME AND MOTH SAMPLES AND BLENDED COMPOSITES (BERMINGHAM WITH FLAME AND MOTH)

The initial batch flotation test on Flame and Moth samples was completed in 2013 by inspectorate Labs and then subsequently was optimized in 2018 in the SGS test work. The 2018 batch cleaner flotation test results are listed in Table 10-11, together with the optimum batch cleaner flotation test results. These results suggest that Flame and Moth material could be sensitive to regrinding. This agrees with the mineralogy observations on Flame and Moth samples, which showed a smaller portion of exposed galena with a greater association of sphalerite and pyrite complex mineralogy.

The locked cycle flotation tests on Flame and Moth samples from each of the zones were performed by SGS between 2018 and 2019. SGS conducted five locked cycle flotation tests: one Christal Zone composite sample, one Lightning Zone composite sample, one Bermingham – Flame and Moth (Lightning Zone) blended sample, and two Bermingham – Flame and Moth blended samples (30% Bermingham to 70% Lightning or Christal Zone).

The basic flowsheet used in the locked cycle flotation tests is shown in Figure 10-6. The ground feed samples had a particle size of P80 between 107 µm to 132 µm, which were first treated in a two-stage silver-lead rougher flotation. Then, the silver-lead rougher concentrate was reground to approximately 80% passing 23 µm to 31 µm, prior to the three-stage cleaner flotation circuit to produce a final silver-lead cleaner concentrate. ZnSO₄ was used in the lead circuit to depress sphalerite and 3418A was used as the lead collector. The silver-lead rougher tailings, first cleaner tailings, and second cleaner tailings from the lead circuit were combined and sent to the zinc circuit, which included a two-stage zinc rougher flotation, followed by a regrinding to approximately 80% passing 25 µm to 35 µm and a two-stage zinc

cleaner flotation. CuSO_4 was used to activate the previously depressed sphalerite and SIPX was used as the zinc circuit collector.

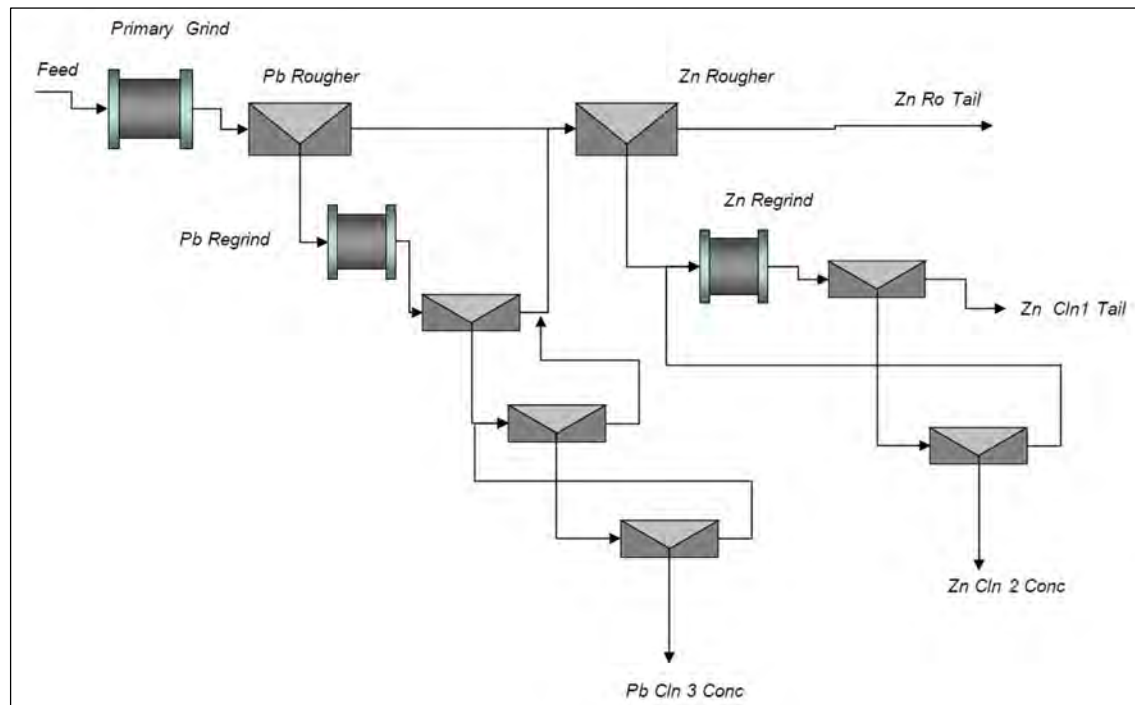

Figure 10-6 – Locked Cycle Flotation Tests Flowsheet on Flame and Moth and Blended Samples (SGS, 2018b).

The test results are listed in Table 10-12. All the five locked cycle tests generated high-grade silver-lead concentrates containing 10,853 g/t to 23,191 g/t Ag and 47.6% to 53.3% Pb. The corresponding recoveries ranged from 85.2% to 96.1% for silver and 77.8% to 92.7% for lead.

The blended samples (Flame and Moth plus Bermingham) produced better silver-lead concentrates with higher recoveries than composite samples for Flame and Moth alone. These tests on the blended mill feed are considered more representative for future mill operation as the expected mill production is based on blended material of Flame and Moth with Bermingham or Lucky Queen deposit.

The zinc concentrates produced from all the locked cycle tests ranged from 49.8% to 54.2% Zn with recoveries ranging from 73.6% to 88.5%. All samples produced similar zinc concentrate grades and recoveries. The blended feed samples (i.e., Bermingham plus Flame and Moth) samples produced similar-grade zinc concentrates and recoveries as compared with individual mine composite samples. Zinc contents recovered to the silver-lead concentrates were between 5.9% to 12.8% grading at 4.8% to 9.1% Zn, while lead contents reported to zinc concentrates ranged from 1.4% to 4.6% grading at 0.9% to 1.9% Pb. Gold recovery to the lead concentrate was 36.2% to 41.6% with a grade from 2.2 g/t to 3.9 g/t Au.

10.4.5 BIRMINGHAM SAMPLES

The batch flotation test work on Birmingham samples was completed between 2017 and 2019 by SGS on one master composite sample. The 2017 open cycle cleaner flotation tests are plotted in Figure 10-7, which shows that although high-grade lead concentrate can be produced, the grade of zinc concentrates was found to be low.

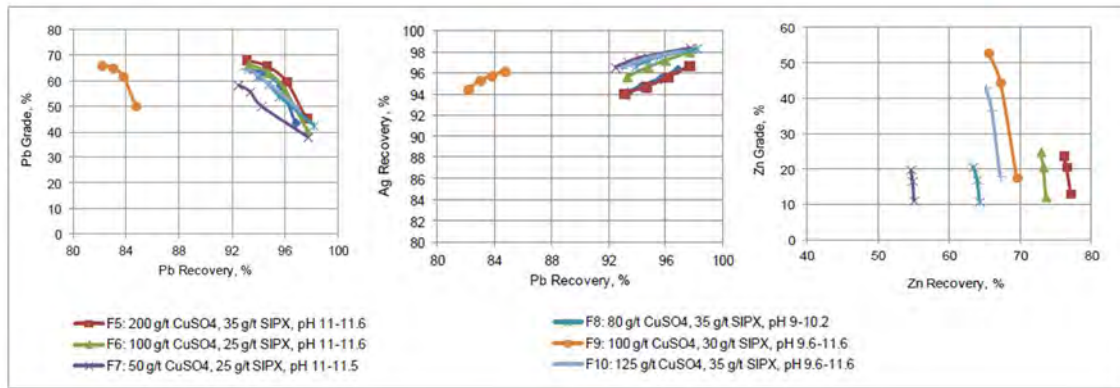

Figure 10-7 – Open Cycle Cleaner Flotation Test Results on Birmingham Master Composite Samples (SGS, 2018a).

In the 2019 optimization batch flotation tests, SGS included two regrinding stages on both lead and zinc rougher concentrates. As shown in Table 10-13, satisfactory results were obtained - the lead concentrate was grading at over 32,000 g/t silver and 60% lead; the zinc concentrate was grading at 58.4% zinc.

Two locked cycle flotation tests were completed on the Birmingham Master Composite sample by SGS in 2017. The flowsheet used in the test is shown in Figure 10-8. The feed samples were ground to particle size P80, approximately 150 μm, which was followed by a silver-lead rougher flotation. The silver-lead rougher concentrate reported to the three-stage cleaner flotation circuit to produce a final silver-lead cleaner concentrate. The lead second cleaner tailings and third cleaner tailings were returned to the previous circuit to further recover silver and lead. ZnSO₄ was used in the silver-lead circuit to depress sphalerite and 3418A was used as the lead collector. The silver-lead rougher tailings and first cleaner tailings fed the lead circuit composed of a zinc rougher flotation and a two-stage zinc cleaner flotation. CuSO₄ was used in the zinc circuit to activate the previously depressed sphalerite and SIPX was used as the zinc circuit collector.

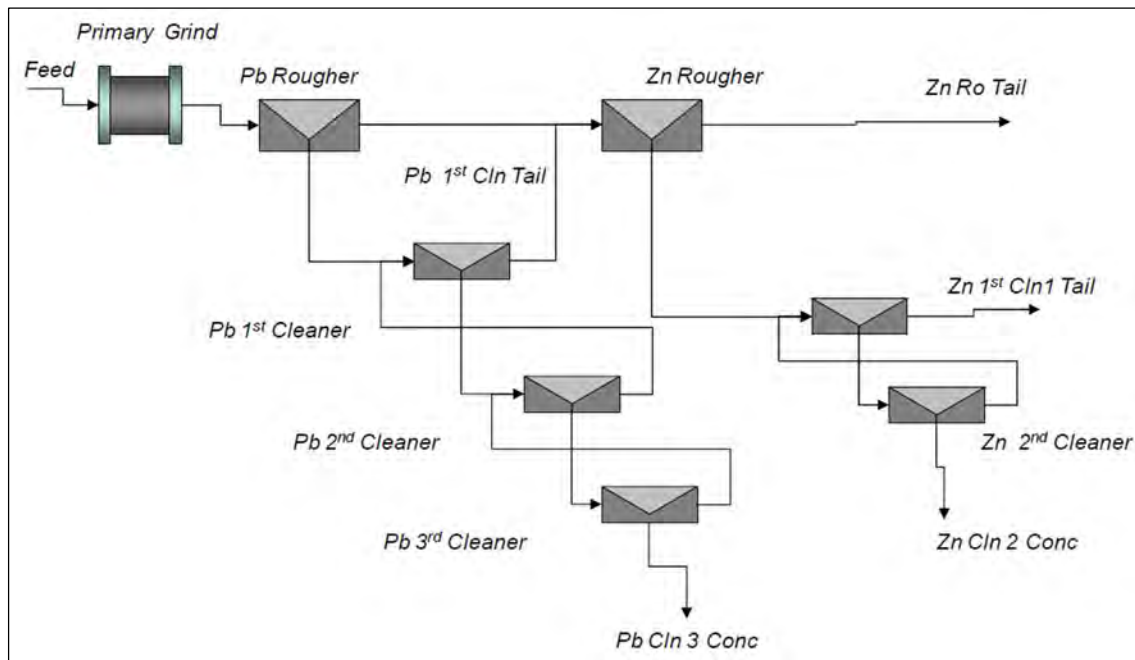

Figure 10-8 – Locked Cycle Flotation Tests Flowsheet on Bermingham Master Composite Samples (SGS, 2018a).

The test results are listed in Table 10-14 with LCT 1 test, high-grade silver-lead concentrates were generated containing 35,972 g/t Ag and 58.4% Pb at the corresponding recoveries of 95.9% for silver and 86.7% for lead. The zinc concentrate was graded at 48.3% Zn at a recovery of 60.0%. The LCT2 test was performed with a modified reagent scheme, including a higher dosage of 3418 A to increase lead recovery, more CuSO₄, and a higher pH level to improve lead recovery. The resulted silver-lead concentrates contained 31,597 g/t Ag and 56.7% Pb with the corresponding recoveries of 97.5% for silver and 95.3% for lead. The zinc concentrates were graded as 52.8% Zn at a recovery of 63.6%. The flotation performance of lead and zinc were improved with the LCT2 test.

Table 10-9 – Locked Cycle Flotation Test Results on Bellekeno Samples (Alexco, 2021b).

Test No.	Head Grade			Lead Cleaner Concentrate									Zinc Cleaner Concentrate					
				Mass	Grade			Recovery			Mass	Grade			Recovery			
	Ag (g/t)	Pb (%)	Zn (%)	%	Ag (g/t)	Pb (%)	Zn (%)	Ag (g/t)	Pb (%)	Zn (%)	%	Ag (g/t)	Pb (%)	Zn (%)	Ag (g/t)	Pb (%)	Zn (%)	
PRA 1996	1,022	12.73	4.51	15.6	6,253	77.6	0.88	95.7	95.3	3.1	8.2	233	2.56	52.1	1.9	1.6	94.3	
SGS 2007	1,227	12.2	11.6	16.4	5,864	72.5	5.37	78.4	97.6	7.6	14.9	750	0.45	56.0	9.1	0.6	71.7	
PRA 2008/2009 – LCT1	933.1	13.1	11.2	18.0	4,874	72.0	2.2	94.0	98.8	3.6	17.1	200.7	0.4	61.5	3.7	0.5	94.4	
PRA 2008/2009 – LCT2	963.5	13.8	10.5	18.8	4,878	72.0	3.1	95.2	98.2	5.6	18.2	157.9	0.3	53.1	3.0	0.4	92.2	
PRA 2008/2009 – LCT3	270.2	1.9	17.0	3.2	5,705	53.1	5.0	68.3	89.6	1.0	28.1	254.8	0.5	59.1	26.5	7.0	97.6	

Table 10-10 – Open Cycle Cleaner Flotation Tests on Lucky Queen Test Samples (Alexco, 2021b).

Test No.	Calc Head Grades			Lead Rougher Concentrate									Lead Cleaner Concentrate					
				Mass	Grade			Recovery			Mass	Grade			Recovery			
	Ag (g/t)	Pb (%)	Zn (%)	%	Ag (g/t)	Pb (%)	Zn (%)	Ag (g/t)	Pb (%)	Zn (%)	%	Ag (g/t)	Pb (%)	Zn (%)	Ag (g/t)	Pb (%)	Zn (%)	
F9	2,322	4.5	3.4	11.4	20,144	39.1	5.2	99.1	98.5	17.3	6.6	33,084	65.9	3.0	93.3	95.1	5.7	
F10	4,965	9.7	4.8	20.0	24,637	48.0	5.0	99.1	98.5	21.0	12.1	34,837	70.5	1.9	84.6	87.3	4.8	

Test No.	Head Distribution			Zinc Rougher Concentrate									Zinc Cleaner Concentrate					
				Mass	Grade			Recovery			Mass	Grade			Recovery			
	Ag (g/t)	Pb (%)	Zn (%)	%	Ag (g/t)	Pb (%)	Zn (%)	Ag (g/t)	Pb (%)	Zn (%)	%	Ag (g/t)	Pb (%)	Zn (%)	Ag (g/t)	Pb (%)	Zn (%)	
F9	100	100	100	8.3	160	0.3	33.2	0.6	0.5	80.3	4.3	215	0.2	58.8	0.4	0.2	73.6	
F10	100	100	100	12.3	233	0.7	30.3	0.6	0.9	78.2	5.9	301	0.7	58.9	0.4	0.4	72.5	

Table 10-11 – Open Cycle Cleaner Flotation Test Results on Flame and Moth Samples (Alexco, 2021b).

Test No.	Head Grade			Lead Rougher Concentrate									Lead Cleaner Concentrate					
				Mass	Grade			Recovery			Mass	Grade			Recovery			
	Ag (g/t)	Pb (%)	Zn (%)	%	Ag (g/t)	Pb (%)	Zn (%)	Ag (g/t)	Pb (%)	Zn (%)	%	Ag (g/t)	Pb (%)	Zn (%)	Ag (g/t)	Pb (%)	Zn (%)	
Flame and Moth-F8	751	2.3	7.2	16.0	4,159	12.8	9.26	88.8	88.7	20.7	3.3	16,963	53.1	5.0	73.9	75.1	2.3	
Lightning Zone-F1	646	3.3	5.3	12.4	4,725	21.0	10.5	90.7	80.2	24.3	4.3	12,645	53.6	7.4	83.7	70.5	5.9	
Lightning Zone-F2	671	3.3	5.6	16.0	3,855	17.4	10.4	92.0	85.3	29.8	5.1	11,228	49.4	8.4	85.2	76.9	7.6	
Lightning Zone-F3	679	3.1	5.5	16.9	3,643	16.1	11.2	90.7	89.1	34.3	3.5	15,110	58.3	4.5	77.1	66.0	2.8	
Christal Zone-F1	786	3.4	5.2	16.7	4,468	19.6	7.0	95.0	96.2	22.7	2.4	11,685	50.1	5.0	91.3	90.6	5.9	

Test No.	Head Distribution			Zinc Rougher Concentrate									Zinc Cleaner Concentrate					
				Mass	Grade			Recovery			Mass	Grade			Recovery			
	Ag (g/t)	Pb (%)	Zn (%)	%	Ag (g/t)	Pb (%)	Zn (%)	Ag (g/t)	Pb (%)	Zn (%)	%	Ag (g/t)	Pb (%)	Zn (%)	Ag (g/t)	Pb (%)	Zn (%)	
Flame and Moth-F8	100	100	100	18.8	273	0.6	29.5	6.8	4.6	77.3	8.7	384	0.5	54.0	4.4	1.8	65.2	
Lightning Zone-F1	100	100	100	17.2	310	1.3	22.3	8.2	6.8	71.9	6.3	417	1.0	50.8	4.1	2.0	60.1	
Lightning Zone-F2	100	100	100	19.8	239	0.9	19.1	7.1	5.7	67.8	6.9	380	0.9	51.2	3.9	1.9	63.2	
Lightning Zone-F3	100	100	100	20.4	201	0.7	17.2	6.0	4.9	63.5	6.4	358	0.8	51.0	3.4	1.7	59.4	
Christal Zone-F1	100	100	100	20.6	130	0.3	19.2	3.4	1.8	76.5	7.2	242	0.3	52.1	2.2	0.6	72.2	

Table 10-12 – Locked Cycle Flotation Test Results on Flame and Moth and Blended Flame and Moth with Bermingham (Alexco, 2021b).

Test No.	Head Grade				Lead Cleaner Concentrate									Zinc Cleaner Concentrate								
					Mass	Grade				Recovery				Mass	Grade				Recovery			
	Ag (g/t)	Pb (%)	Zn (%)	Au (g/t)	%	Ag (g/t)	Pb (%)	Zn (%)	Au (g/t)	Ag (g/t)	Pb (%)	Zn (%)	Au (g/t)	%	Ag (g/t)	Pb (%)	Zn (%)	Au (g/t)	Ag (g/t)	Pb (%)	Zn (%)	Au (g/t)
LCT1 ¹	811	3.7	5.4	-	6.3	12,049	52.1	5.0	5.5	91.9	89.4	5.9	36.2	8.4	344	0.9	54.2	0.33	3.4	2.1	83.8	2.9
LCT2 ²	645	3.3	5.7	-	5.4	10,853	47.6	9.1	-	85.2	77.8	8.7	-	8.6	515	1.8	49.8	-	6.4	4.6	75.5	-
LCT3 ³	1,596	4.5	4.3	0.71	8.1	19,270	51.6	4.8	3.4	96.1	92.7	9.1	36.8	6.8	443	1.0	53.5	0.44	1.9	1.4	84.7	4.0
LCT4 ⁴	1,769	4.3	4.4	0.37	7.2	23,191	51.7	7.8	2.2	94.2	86.5	12.8	41.6	6.5	564	1.9	49.8	0.26	2.07	2.8	73.6	4.4
LCT5 ⁵	1,115	3.7	4.6	0.66	6.3	16,266	53.3	5.2	3.9	92.3	90.7	7.1	37.5	7.7	524	1.0	53	0.65	3.6	2.0	88.5	7.6

Notes:

- 1) LCT1 - Christal Zone Composite.
- 2) LCT2 - Lightning Zone Composite.
- 3) LCT3 - Bermingham Master Composite-Christal Zone Blend.
- 4) LCT4 - Bermingham Master Composite-Lightning Zone Blend.
- 5) LCT5 - New Bermingham Composite-Christal Zone Blend.

Table 10-13 – Open Cycle Cleaner Flotation Test Results on Bermingham Sample (SGS, 2019).

Test No.	Calc Head Grades			Lead Rougher Concentrate							Lead Cleaner Concentrate						
				Mass	Grade			Recovery			Mass	Grade			Recovery		
	Ag (g/t)	Pb (%)	Zn (%)	%	Ag (g/t)	Pb (%)	Zn (%)	Ag (g/t)	Pb (%)	Zn (%)	%	Ag (g/t)	Pb (%)	Zn (%)	Ag (g/t)	Pb (%)	Zn (%)
Bermingham - F1	1,712	3.57	2.95	19.5	8,393	17.6	5.34	95.5	96.1	35.3	4.7	32,484	60.5	4.1	88.5	79.1	6.6
Test No.	Head Distribution			Zinc Rougher Concentrate							Zinc Cleaner Concentrate						
				Mass	Grade			Recovery			Mass	Grade			Recovery		
	Ag (g/t)	Pb (%)	Zn (%)	%	Ag (g/t)	Pb (%)	Zn (%)	Ag (g/t)	Pb (%)	Zn (%)	%	Ag (g/t)	Pb (%)	Zn (%)	Ag (g/t)	Pb (%)	Zn (%)
BM-F1	100	100	100	12.9	508	0.66	14.4	3.8	2.4	63.3	2.7	1,405	0.63	58.4	2.2	0.5	52.9

Table 10-14 – Locked Cycle Flotation Test Results on Bermingham Samples (Alexco, 2021b).

Test No.	Sample	Head Grade			Lead Cleaner Concentrate							Zinc Cleaner Concentrate						
					Mass	Grade			Recovery			Mass	Grade			Recovery		
		Ag (g/t)	Pb (%)	Zn (%)	%	Ag (g/t)	Pb (%)	Zn (%)	Ag (g/t)	Pb (%)	Zn (%)	%	Ag (g/t)	Pb (%)	Zn (%)	Ag (g/t)	Pb (%)	Zn (%)
LCT1	Bermingham Master Composite	3,446	6.2	1.8	9.2	35,972	58.4	3.8	95.9	86.7	19.4	2.3	1,324	3.0	48.3	0.9	1.1	60.0
LCT2	Bermingham Master Composite	3,574	6.6	1.9	11.0	31,597	56.7	4.1	97.5	95.3	24.0	2.3	1,283	2.4	52.8	0.8	0.8	63.6

10.4.6 MISCELLANEOUS TEST WORK

The 1996 and 2008/2009 test programs by PRA included a series of miscellaneous tests, namely settling tests, filtration tests, and an analysis of flotation tailings. A summary of the previous test work by PRA is presented in this report. Details can be found in the 2009 PEA report by Wardrop (Wardrop, 2009).

The latest test work was done in 2023 on the Bear zone in Bermingham deposit by Blue Coast flotation.

Settling tests were performed on samples of both Bellekeno lead and zinc concentrates and the tailings. Two flocculants, Percol 156 and Percol 351, were tested in the two test programs. An average unit thickener area of 0.02 m²/tpd was identified for the mill design criteria. Vacuum filtration tests were performed in the 2008/2009 testing on samples of lead and zinc concentrates without any issues reported.

Whole rock assay and inductively coupled plasma (ICP) analysis were performed by PRA in 2008 on bulk tailings samples to determine the chemical characteristics. The main components identified were silicon and iron. The tailings water was also assayed by the ICP scan. Acid-based accounting tests were performed on low and high-sulfide tailings samples to determine their acid-generating potential. The results indicated that the bulk tailings (low sulfide) were not likely acid-generating; however, the zinc cleaner scavenger tailings may pose some acid-generation potential.

10.5 METALLURGICAL PERFORMANCE PREDICTION

From the mineralogy comparison, the deposits of Bellekeno, Bermingham, and Lucky Queen can be considered high-grade and coarse-grained in nature, while the deposit of Flame and Moth was found less coarse-grained with a greater association of sphalerite and pyrite complex. The blending of Flame and Moth deposit with other deposits could produce a good flotation response which has been illustrated in the locked cycle flotation tests on the blended samples. In addition, the optimized lead rougher recovery of the four individual deposits tends to range from 89% to 98%. This indicates that a well cleaner flotation performance can be expected. As a result, the overall flotation recovery for this Project can be estimated by using both the open circuit flotation test results and the locked cycle test data which can also provide confirmation or validity for the former data.

Specifically, metal recoveries of silver, lead, and zinc were projected based on the optimized test results obtained from the locked cycle and open cycle flotation test programs on the representative samples under the LOM mine plan reported herein, while test data from the potentially oxidized samples, the samples with higher head grades than the LOM's estimates, or the samples collected from locations beyond the planned mine areas were not included in this projection. Metal recoveries from the batch open cleaner flotation tests were adjusted according to locked cycle results to reflect the middling recirculation and regrinding effects on overall metallurgical performances.

The metal recoveries with varied head grades on the selected samples are plotted in Figure 10-9. The red dots represent the data from the locked cycle tests, while the green dots represent the data from the

batch open cleaner flotation tests. The trendline was developed from both the locked cycle test data and the batch open cleaner test data.

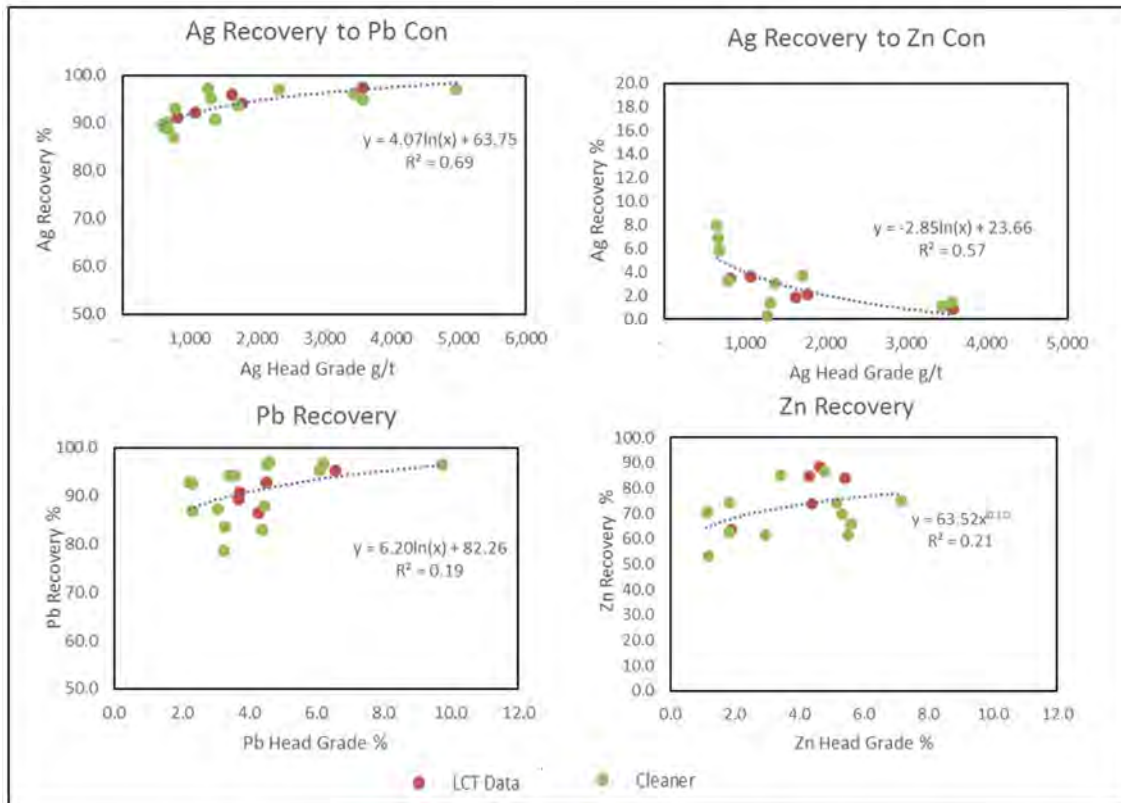

Figure 10-9 – Metal Recoveries at Head Grades for Recovery Projection (Alexco, 2019a).

In general, a reasonable relationship can be observed between silver head grades and silver recoveries. For lead recovery to lead concentrates, a weak dependence on the feed grade was observed. This may be caused by various test conditions used by different laboratories. However, when considering the locked cycle test data only, which were drawn from SGS tests, the lead grade-recovery relationship appears to be better. With zinc recovery to zinc concentrates, the dependence on feed grade is also weak as part of zinc reporting to lead concentrates. Variability locked cycle tests are therefore recommended to verify the observed trends using blended samples according to the LOM production plan.

A regression analysis was used to model the metal recoveries with varied head grades Table 10-15 summarizes the projected metal recoveries for all the deposits included in this Project. When the feed grades are beyond the ranges specified in the table, constant metal recovery is recommended in the projection. A Zn to Pb concentrate recovery formula was not generated; instead, a constant recovery value of silver, lead, and zinc were applied to the mine schedule and calculated the recovered amount of silver, lead, and zinc concentrate.

Table 10-15 – Silver and Zinc Concentrate Recoveries and Grades (Hecla, 2024).

Silver Concentrate		Zinc Concentrate	
Concentrate Recoveries			
Ag	92.0%	Ag	4.0%
Pb	88.0%	Pb	5.2%
Zn	4.0%	Zn	68.0%
Concentrate Grades			
Ag	15,550 gpt	Ag	741 gpt
Pb	45.0%	Pb	3.3%
Zn	2.5%	Zn	47.0%

Note: Assumed values were provided by Keno Hill monthly operation data 2023 and Cost Model 2023 for the 11-year mine plan.

11. MINERAL RESOURCE ESTIMATES

11.1 SUMMARY

The Keno Hill Silver District 2023 Mineral Resource Estimate consists of five discrete estimates from the following areas: Bellekeno, Lucky Queen, Flame and Moth, Onek, and Bermingham.

The Mineral Resource Models for Bellekeno, Lucky Queen, and Onek were developed in earlier studies under the supervision or review of different Qualified Persons (QP's). These deposits have maintained their original state, with no modifications made, as no new information or geological interpretation is prompting an update. The creation of these models and their contributions are outlined below.

- The Mineral Resource model for Bellekeno is the fourth Mineral Resource evaluation prepared for the Bellekeno deposit in accordance with SEC definitions. The Mineral Resource model and estimation work was prepared by Alexco personnel under the supervision of a third-party consulting geologist. It considers 424 drillholes drilled by Alexco during the 2006–2013 period along with chip sampling during the mining period of 2009–2013. It also includes historic drilling and chip samples. In 2021, resource model for the Bellekeno deposit was reviewed by Mr. Cliff Revering, P.Eng., of SRK and found to be completed to a standard acceptable to SRK and in accordance with NI 43-101.
- The Mineral Resource model for the Lucky Queen deposit was prepared by SRK and published in an independent technical report on September 8, 2011. The author of the report was Dr. Gilles Arseneau, Ph.D., P.Geo. The report is titled “Technical Report on the Lucky Queen Deposit, Lucky Queen Property, Keno Hill District, Yukon”.
- The Mineral Resource estimate for the Onek deposit was prepared by SRK and published in an independent technical report on September 8, 2011. The author of the report was Dr. Arseneau. The report is titled “Technical Report on the Onek Deposit, Onek Property, Keno Hill District, Yukon.” The Onek Mineral Resource has been updated in this report to include the results of additional drilling carried out in 2012 and 2013.

The Mining Plus geology QP conducted a review of the Mineral Resource models for the Lucky Queen and Onek deposits. The assessment confirmed that the models were completed to a standard deemed acceptable by Mining Plus and in accordance with SEC definitions. Additionally, the assessment brought to light opportunities for improvement in future updates.

Furthermore, the Mining Plus geology QP assessed the Bellekeno model, where several inconsistencies between the block model and raw data were detected and have not been sufficiently resolved. Primary inconsistencies arise from incomplete or unclear data within the original files, impeding proper traceability and exact replication. Additionally, certain domains exhibit an apparent overestimation of zinc, and the smallest domain displays an overestimation of silver. Density calculations are derived from the grades of silver, lead and zinc, posing a potential for overestimation in some domains. The reasons behind this overestimation are unclear and necessitate further investigation.

Bellekeno’s resource contribution represents only 4% of global silver ounces. Any potential issues with this deposit are considered insignificant, leading to the downgrade from indicated to inferred resources. Unclassified blocks remain unclassified. Nevertheless, it is advised to undertake a new resource estimate for Bellekeno, taking into consideration the noted discrepancies.

All information in this section pertaining to Bellekeno, Lucky Queen, and Onek is extracted from previous studies.

In October 2023, Hecla developed the Mineral Resource model for the Flame and Moth deposit, followed by the completion of the Mineral Resource model for the Bermingham deposit in November 2023. The Mining Plus geology QP conducted a thorough examination of both models, confirming their suitability for reporting Mineral Resources in compliance with Mining Plus standards and SEC definitions.

The Mineral Resource statement for the Keno Hill Project presented in Table 11-1 considered potentially mineable through optimized underground mining methods. All Mineral Resources declared in this report are reported inside an underground shapes optimization with an economic cut -off of CAD 185/tonne.

Table 11-1 – Summary of Mineral Resources – December 31, 2023 – Hecla Yukon – Keno Hill Mine.

Category	Deposit	Mass (,000 t)	Ag (g/t)	Pb (%)	Zn (%)	Au (g/t)	Contained Silver (,000 oz)
Indicated	Bellekeno	-	-	-	-	-	-
	Lucky Queen	135	340	0.72	0.70	0.07	1,472
	Flame and Moth	1,629	256	0.87	3.37	0.21	13,389
	Onek	901	150	1.00	8.38	0.41	4,349
	Bermingham	1,421	322	0.92	0.81	0.06	14,716
	Total Indicated	4,086	258	0.91	3.49	0.20	33,926
Inferred	Bellekeno	372	229	0.75	3.98	-	2,735
	Lucky Queen	212	312	0.74	0.58	0.05	2,123
	Flame and Moth	184	207	0.32	3.04	0.15	1,220
	Onek	234	96	0.74	5.68	0.28	721
	Bermingham	1,571	495	1.42	0.77	0.10	24,991
	Total Inferred	2,573	384	1.13	1.83	0.10	31,791

Notes:

1. Classification of the Mineral Resource is in accordance with the S-K 1300 classification system.
2. Mineral Resources were estimated by Hecla and reviewed and accepted by Mining Plus.
3. Mineral Resources are reported in-situ and are exclusive of Mineral Reserves.
4. Mineral Resources are 100% attributable to Hecla.
5. Totals may not represent the sum of the parts due to rounding.
6. Mineral Resources were estimated using an NSR cut-off value of CAD 185/tonne and a minimum mining width of 1.5 m.
7. The Mineral Resource estimates for the Bermingham and Flame and Moth mines have an effective date of December 31, 2023
8. The Mineral Resource estimates for the Lucky Queen and Onek deposits have an effective date of January 3, 2017.
9. The Mineral Resource estimate for the Bellekeno deposit is based on an internal Mineral Resource estimate completed by Alexco Resource Corp. and externally audited by Mining Plus. This Mineral Resource estimate has been depleted to reflect all mine production from Bellekeno to the end of December 2021. Bellekeno deposit has an effective date of December 31, 2023.

11.2 KEY ASSUMPTIONS, PARAMETERS, AND METHODS

11.2.1 DRILLHOLE DATABASE

11.2.1.1 Database for the Bellekeno Deposit

The Bellekeno database includes all samples taken during both historic and more recent sampling campaigns, up to and including samples collected in November 2013. This data includes surface and underground drilling, underground face, and wall (chip) samples, both recent and historical. A summary of the data in the database is listed in Table 11-2 and samples from within the defined geological solids used for Mineral Resource Estimation are listed in Table 11-3.

Table 11-2 – Bellekeno Deposit Sample Database (Alexco, 2021b).

Sample Type	Count	Number of Samples	Length (m)
Chip	2,739	10,217	9,277
Core (Surface)	65	8,541	15,274
Core (Underground)	379	8,128	10,607
Total	3,183	26,886	35,603

Table 11-3 – Bellekeno Deposit Samples used for Mineral Resource Estimation (Alexco, 2021b).

Sample Type	Count	Number of Samples	Length (m)
Chip	1,856	4,926	4,006
Core (Surface)	38	217	185
Core (Underground)	310	1,914	1,352
Total	2,204	7,057	5,543

The Mineral Resource database was inspected for inconsistencies in naming conventions, duplicate entries, lengths, and distance values. A few assays marked as below detection limit, zeros, and missing or non-sampled intervals were investigated and adjusted prior to further analysis. Drillhole assays below detection limits were allocated a value one-half the lower detection limit at 0.05 ppm. Non-sampled chip intervals were given a value of 0.01 ppm and flagged. All drillhole missing sample intervals were due to non-recovered core in poor ground conditions and were incorporated as “missing samples” in the compositing stage.

11.2.1.2 Database for the Lucky Queen Deposit

The Lucky Queen dataset used in Mineral Resource Estimation was exported from the SQL database by scripted routine to CSV files, which were imported into MineSight. The following drill hole files were generated: collar, survey, drill hole assay, chip sample assay, geology, and geotechnical.

The Lucky Queen database comprises descriptive information and assay values both from historical underground sampling and from exploration drilling carried out by Alexco from 2006 through 2010. The database was provided to SRK as an Excel format spreadsheet with a total of 558 records encompassing 47 core drill holes and 511 historical underground channel samples (Table 11-4). From the drilling results, Alexco identified a total of 106 core drill hole intervals as primary vein intercepts and 26 intervals as secondary splay intercepts, based on a combination of geological logging and assay grades.

Table 11-4 – Lucky Queen Deposit Sample Database (Alexco, 2021b).

Sample Type	Count	Ag (ppm)	Au (ppm)	Pb (ppm)	Zn (ppm)	Vein Width (m)
Historical Chip	511	2,175	NA	50,661	39,216	1
Alexco Core Vein	106	1,426	0	36,523	21,222	1
Alexco Core Splays	26	1,128	0	18,340	6,905	1
Alexco Core other	3,012	4	0	322	378	2

The Mineral Resource database was imported into a GEMS format Access database and validated by checking for:

- Inconsistencies in naming conventions or analytical units.
- Duplicate entries.
- Overlapping intervals.
- Length or distance values less than or equal to zero.
- Blank or zero-value assay results.
- Out-of-sequence intervals.
- Intervals or distances greater than the reported drill hole length.
- Inappropriate collar locations.
- Missing interval and coordinate fields.

Two trivial terminal interval survey distances were noted and corrected; no other significant validation errors were noted in the supplied database. Assay intervals marked as below detection limit were assigned a nominal grade of 0.001 ppm prior to importing into GEMS.

11.2.1.3 Database for the Flame and Moth Deposit

The drilling source data used for the Flame and Moth Resource estimate comprised an ODBC database directly linked to the database (GeoSpark® Software) within the Flame and Moth Leapfrog project. The database was trimmed down with the use of queries within Leapfrog to use only diamond drillhole information for interval selection and estimation purposes. The final database contained 156 drillholes (Alexco and Hecla holes) totaling 38,565.48 m, of which 138 holes contained mineralized domain intervals. For the Mineral Resource update, 54 new holes recently drilled by Hecla (19 for 1,957.50 m) and Alexco (35 for 2,633.30 m) have been included.

The assay table contained 7,109 sample intervals comprising an aggregate length of 7,948.2 m. Of these, 1,777 samples with a combined length of 1,301.78 m are located within the interpreted mineralized domains.

In addition, there are 194 intervals within mineralized domains of core loss totaling 162.49 m that are labeled as “NR” for No Recovery, with no associated assay data. These intervals are mostly found in the Lightning Zone, with the majority occurring in the stringer mineralization (SM) domain. The oblique view presented below (Figure 11-1) shows the distribution of NR samples in the Lightning Zone in relation to the mineralized domains and current mine as-builts. An oblique image showing the high density of NR intervals found around the as-builts is seen in Figure 11-2.

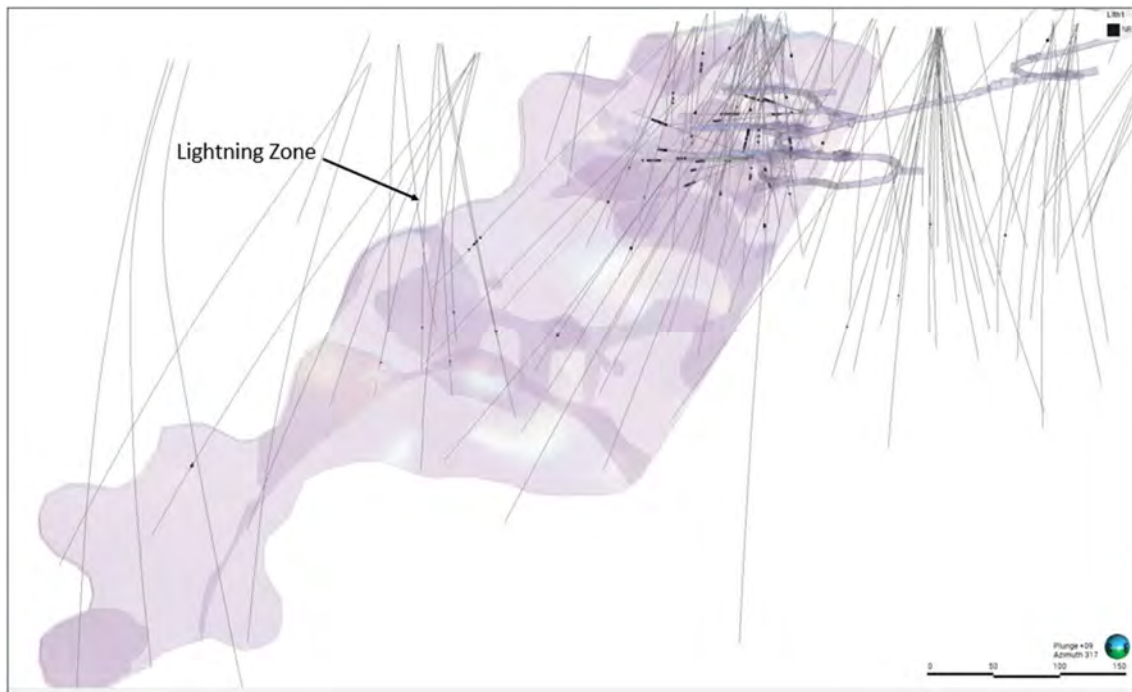

Figure 11-1 – Oblique View of Flame and Moth Lightning Zone Wireframe (Pink), Mine As-built (Blue), Drillhole Traces (Grey), and NR Samples (Black) (Hecla, 2023e).

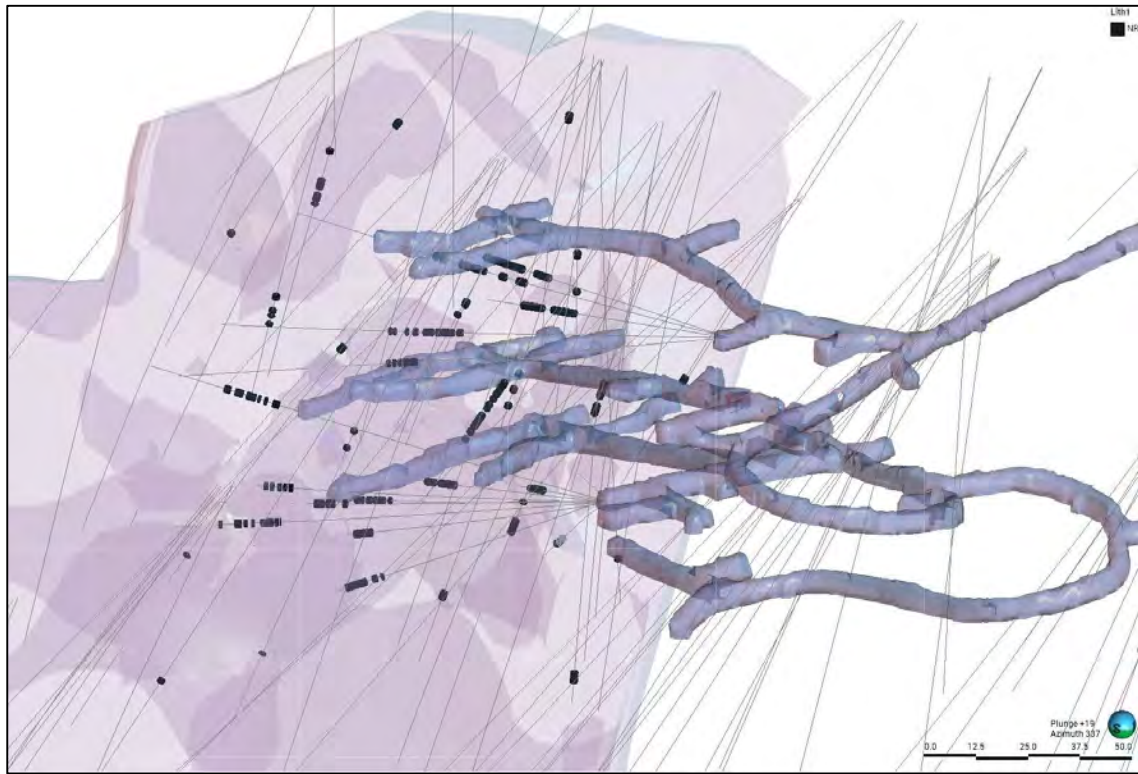

Figure 11-2 – Oblique View of Flame and Moth Lightning Zone Wireframe (Pink), Mine As-built (Blue), Drillhole Traces (Grey), and NR Samples (Black) (Hecla, 2023e).

Mining Plus reviewed the source data for the Flame and Moth mineral resource estimate and noted the distribution of “NR” intervals. While these were considered unlikely to present a material problem, it was recommended that these zones continue to be monitored in future, particularly where they occur within mineralized zones.

11.2.1.4 Database for the Onek Deposit

The Onek data was exported from the SQL database by scripted routine to CSV files, which were imported into MineSight. The following drill hole files were generated: collar, survey, drill hole assay, chip sample assay, geology, and geotechnical.

The Onek database comprises descriptive information and assay values both from historical underground sampling and from exploration drilling carried out by Alexco from 2007 through 2013. The database was provided to SRK as a Microsoft Excel format spreadsheet and contains a total of 1,567 records encompassing 92 core drill holes and 1,302 historical underground channel samples, 10 historical drill holes, 29 percussion holes and 134 test holes (Table 11-5). From the drilling results, Alexco has identified

a total of 106 core drill hole intervals as primary vein intercepts and 26 intervals as secondary splay intercepts, based on a combination of geological logging and assay grades.

Table 11-5 – Onek Deposit Sample Database Average Assay Values Inside Veins (Alexco, 2021b).

Long section	Count	Sample Inside Veins	Ag (g/t)	Au (g/t)	Pb (ppm)	Zn (ppm)
Historical Chip	1,302	1,156	275	NA	23,283	111,645
Alexco Drilling	92	633	215	1	17,134	112,434
Historical Drilling	10	8	NA	NA	6	3,250
Percussion Test Holes	29	72	NA	NA	NA	29,014
Test Holes	134	97	NA	NA	3,277	32,439
Total	1,567	1,966				

The Mineral Resource database was imported into a GEMS format Access database and validated by checking for:

- Inconsistencies in naming conventions or analytical units.
- Duplicate entries.
- Overlapping intervals.
- Length or distance values less than or equal to zero.
- Blank or zero-value assay results.
- Out-of-sequence intervals.
- Intervals or distances greater than the reported drill hole length.
- Inappropriate collar locations.
- Missing interval and coordinate fields.

A few minor inconsistencies were noted and corrected, and no other significant validation errors were noted in the supplied database. Assay intervals marked as below the detection limit were assigned a nominal grade of 0.001 ppm prior to importing into GEMS.

11.2.1.5 Database for the Bermingham Deposit

The database used for resource estimation in Leapfrog Edge software was an ODBC link directly to the GeoSpark® Software database. The database was trimmed down with the use of queries within Leapfrog to use only DDH information for interval selection and estimation purposes. A total of 351 drill holes totalling 104,729.3 m were used in the estimation process, with 263 holes containing mineralized domain intervals. The assay table contained 12,680 samples comprising 12,178.26 m of length. Of these, 2,208 samples with a combined length of 1,432.49 m fell within the mineralized domains. For the Mineral

Resource update, 148 new holes recently drilled by Hecla (73 holes for 12,702.93 metres) and Alexco (75 holes for 26,162.18 m) have been included.

The database contained a set of No Recovery (NR) samples, encompassing 125 intervals with a total length of 85.41 m within the mineralization interpretation. These specific intervals have been designated as ‘OMIT’ in Leapfrog, implying a lack of available data in the software. Consequently, the software operates under the assumption that no data was present, leading to an extrapolation of composited values without any adjustment for potential variations (based on the presumption that missing data is equivalent to available data). An illustrative example for drillhole K-21-0787 is depicted in Figure 11-3.

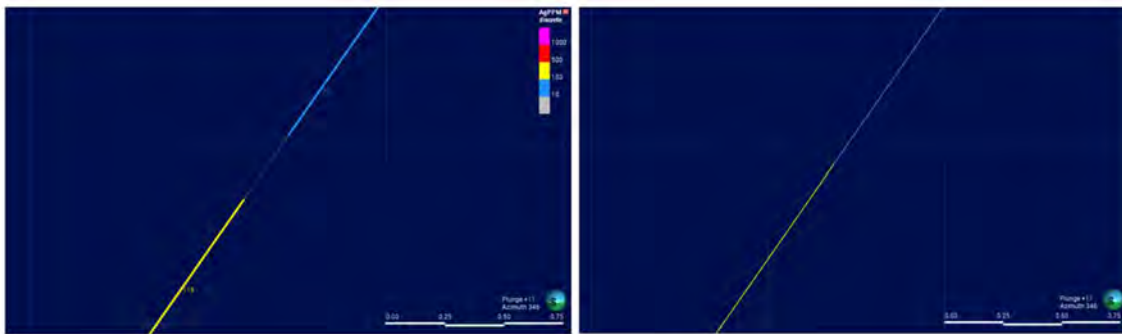

Figure 11-3 – Assay and Composite for Drillhole K-21-0787 in the Arctic Zone.

11.2.2 INTERPRETATION AND MODELLING

11.2.2.1 Mineralization Domaining for the Bellekeno Deposit

Three-dimensional wireframe solids were constructed by Alexco to accurately represent the geometry of the Bellekeno deposit vein structures. The modeled structures exhibit mineralization primarily in the form of sulfides; a weathering surface has not been incorporated during the modeling or estimation process. These wireframes were further reviewed and validated by the QP before Mineral Resource estimation.

Wireframes were constructed for three portions of the Bellekeno deposit: the Southwest (SW) Vein, 99 Vein, and the East Vein and Splay (Figure 11-4, Figure 11-5). The wireframes were constructed using Mintec’s MineSight 3D software by Alexco in 2013. All points of construction on the veins are from Alexco’s core drilling and mapping of underground exposure during mining. Individual points were constructed on the hanging wall and footwall of each drill hole vein/structure intercept. These points were chosen based on the fault/vein structure where, in most cases, the hanging wall and footwall contacts were clear, and the mineralization was contained within a well-defined structure.

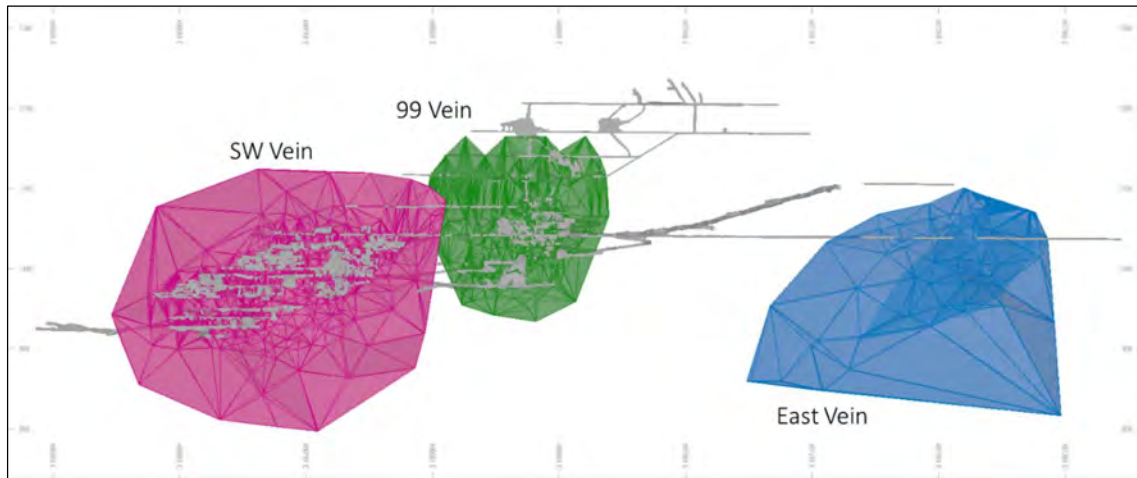

Figure 11-4 – Bellekeno Deposit Long Section, Wireframes, Looking North-Northwest (Alexco, 2021b).

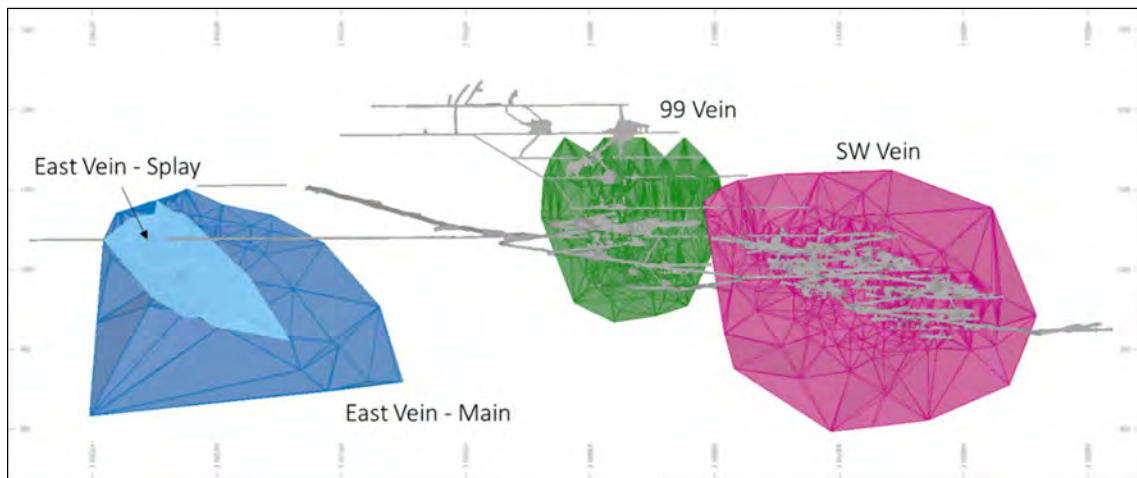

Figure 11-5 – Bellekeno Deposit Long Section, Wireframes, looking South-Southeast (Alexco, 2021b).

11.2.2.2 Mineralization Domaining for the Lucky Queen Deposit

Three-dimensional wireframe solids were constructed by Alexco to accurately represent the geometry of the Lucky Queen deposit vein structures. The modeled structures exhibit mineralization primarily in the form of sulfides; a weathering surface has not been incorporated during the modeling or estimation process. These wireframes were further reviewed and validated by the QP 2011 before Mineral Resource Estimation.

At Lucky Queen, the majority of high-grade, silver-bearing vein material is confined between relatively intact rock of the hanging wall and footwall and is manifested as vein mineral and highly deformed fault rock in varying proportions. High silver values are only rarely found outside the main structure as stringer

zones or splays. The coincidence of high-grade mineralization within identifiable structural limits made it sensible to base the wireframe interpretation on structural and geological controls, and contacts were chosen accordingly. In addition to Alexco drill hole data, historical drill hole data and geological mapping conducted by UKHM were used to constrain the geometry of the main Lucky Queen structure and associated splay structures, where applicable.

Historical drift and stope mapping were considered to be accurate and representative. Field verification of the mapping could not be performed by geologists because the underground workings were inaccessible. However, historical maps of other mines in Keno Hill have been verified and found to be generally accurate in their representation of geology. Historical maps were scanned, geo-referenced, and imported into MineSight. The images were then draped onto drift solids at the appropriate elevation. This mapping was used to tag hanging wall and footwall contacts on the wireframe.

The main Lucky Queen mineralized body occupies a central part of the primary wireframe and the most important constraints delineating it are the lower-grade drill intercepts that occupy locations above, below, and to the northeast. Beyond these drill holes, the wireframe is cut off (approximately) along the deepest extents of the 200 and 300-level historic workings. Fault 3 and Fault 5 terminate the wireframe to the northeast and at shallow elevations, respectively. The earlier Lucky Queen workings included extensive stoping. As a result, it was decided to exclude the entire area containing the 50, 100, 200, and 300 level workings from the wireframe solid. Those areas of the 500 level workings that intersect the wireframes were also removed from the wireframe solid (Figure 11-6).

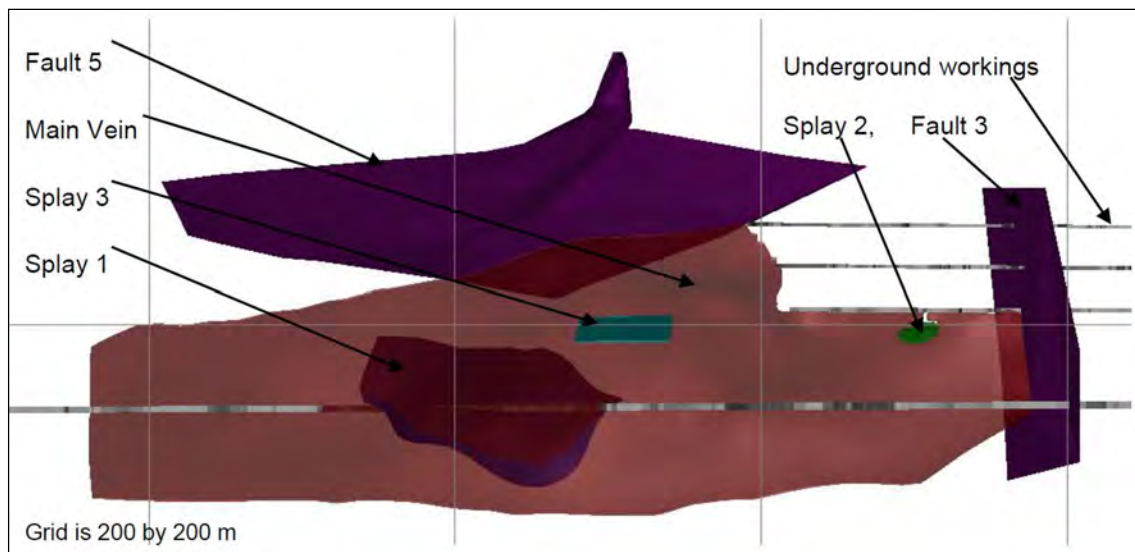

Figure 11-6 – Section of Lucky Queen Wireframes Looking Northwest (SRK, 2011a).

11.2.2.3 Mineralization Domaining for the Flame and Moth Deposit

The mineralization wireframes for Flame and Moth were updated by Ben Chambers using Leapfrog Geo 2023.2 software. A combination of drill hole lithology intervals and underground geologic maps were utilized to accurately adjust wireframes with control points in mined areas based on this information. The Interval Selection tool was then used to select intervals from which the vein shapes were established. Updated mineralization wireframes reflect the more detailed geological information collected underground as geological mapping became more prevalent. Deeper insight into the geology and mineralization behavior has resulted in domains of continuous veining and wider zones of stringer mineralization. The modeled structures exhibit mineralization primarily in the form of sulfides. Therefore, a weathering surface has not been incorporated during the modeling or estimation process.

The QP reviewed the validated wireframes before resource estimation and concluded that the wireframes for the Flame and Moth deposit were fair representations of the mineralized veins and acceptable for resource estimation.

The Flame Vein strikes between 025° and 027° and dips between 62° and 66° to the southeast. The Flame and Moth Vein is offset along the Mill Fault and two wireframes have been constructed to reflect this geological feature. The Flame Vein in the hanging wall of the Mill Fault was termed the Lightning Zone while the portion in the footwall of the Mill Fault was termed the Christal Zone (Figure 11-7).

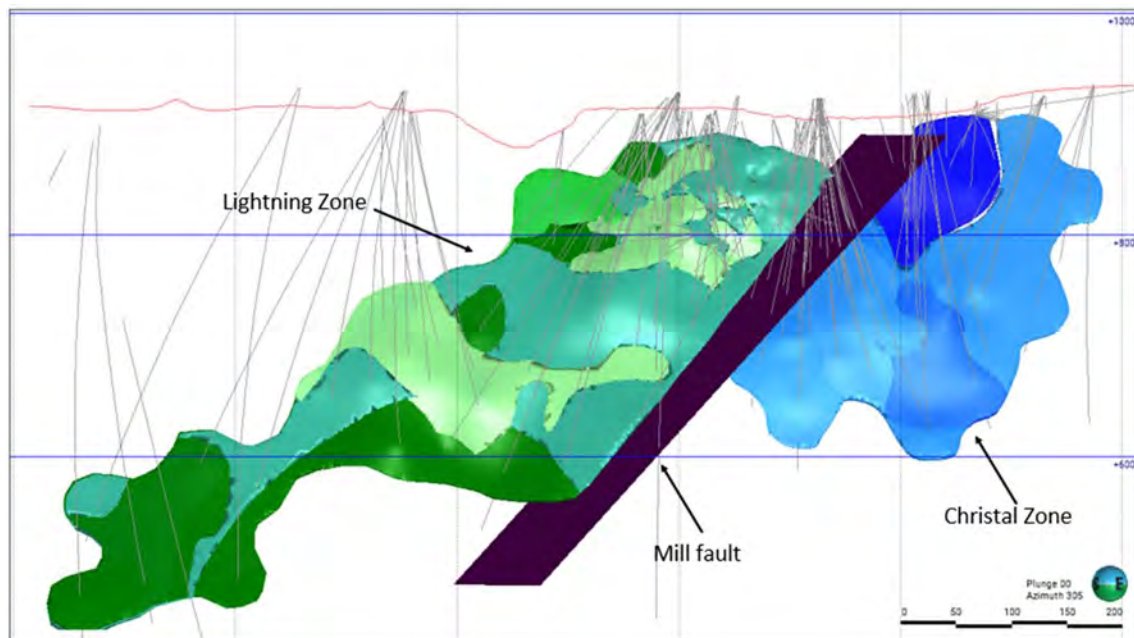

Figure 11-7 – Vein Wireframes and Location of Surface Drilling at Flame and Moth used in Resource Estimation, Section Looking North-Northwest.

During a technical review of the Flame and Moth wireframes, Mining Plus noted that some high-grade mineralization interpretations did not capture the higher-grade drilling assays. This was not seen to be a significant problem where these assays were subsequently captured with the stringer mineralization domain.

11.2.2.4 Mineralization Domaining for the Onek Deposit

Three-dimensional wireframe solids for the Onek deposit were constructed by Alexco to accurately represent the geometry of Onek vein structures. The previous QP reviewed and validated the wireframes before resource estimation. The QP concluded that the wireframes of the Onek deposit were fair representations of the mineralized veins and acceptable for resource estimation.

Wireframes for three separate veins were constructed for Onek: Vein 1, Vein 2, and Vein 1FW. Vein 1 is the dominant vein-fault structure at Onek, extending over 600 m in length and up to 260 m in depth (Figure 11-8). The vein is interpreted to extend through all drilling done to date and to encompass the drifts, stopes, and raises of the historical workings. The vein-fault thickness varies from approximately 7.5 m to less than 1 m but, on the whole, is fairly thick and persistent. Drilling to the southwest intersected reduced grade and will act as a constraint to the strike extent of the mineralization. On the northeastern end of the deposit, underground mapping on the 400 level showed the vein narrowing and splitting into two, with the likely more dominant structure curving to the southeast and ending with sporadic mineralization in a possible cross fault.

Vein 2 forms an anastomosing structure in the hanging wall of Vein 1, with repeated convergence and divergence from the Vein 1 structure, as seen in the drill holes and underground level plan mapping. Vein 2 thickness was reduced and less consistent than Vein 1 and the mineralization had much less continuity. This was regarded as a secondary structure in the Onek deposit. Vein 2 also bends sharply to the east at the northeastern end of the deposit where intercepts in the drill holes are much more sporadic. Several small weakly mineralized vein intercepts were noted in the hanging wall of Vein 2, but the continuity of mineralization could not be established, and they are not modeled at this time (Figure 11-9).

Two drill holes, K-08-0149 and K-10-0244, were drilled from separate collar locations but passed within 0.5 m of each other within the Vein 2 shape. As the location of Vein 2 in the hole K-08-0149 could not be reconciled with the Vein 2 location in hole K-10-0244 without significant deviation in the wireframe, and since the K-10-0244 intercept had better survey control and was less oblique to the vein surface, the K-08-0149 Vein 2 intercept was excluded from the wireframe.

A third vein, Vein 1FW, was identified in several drill holes at the southwestern end of the deposit, likely splaying sharply off Vein 1, and was modeled for resource estimation.

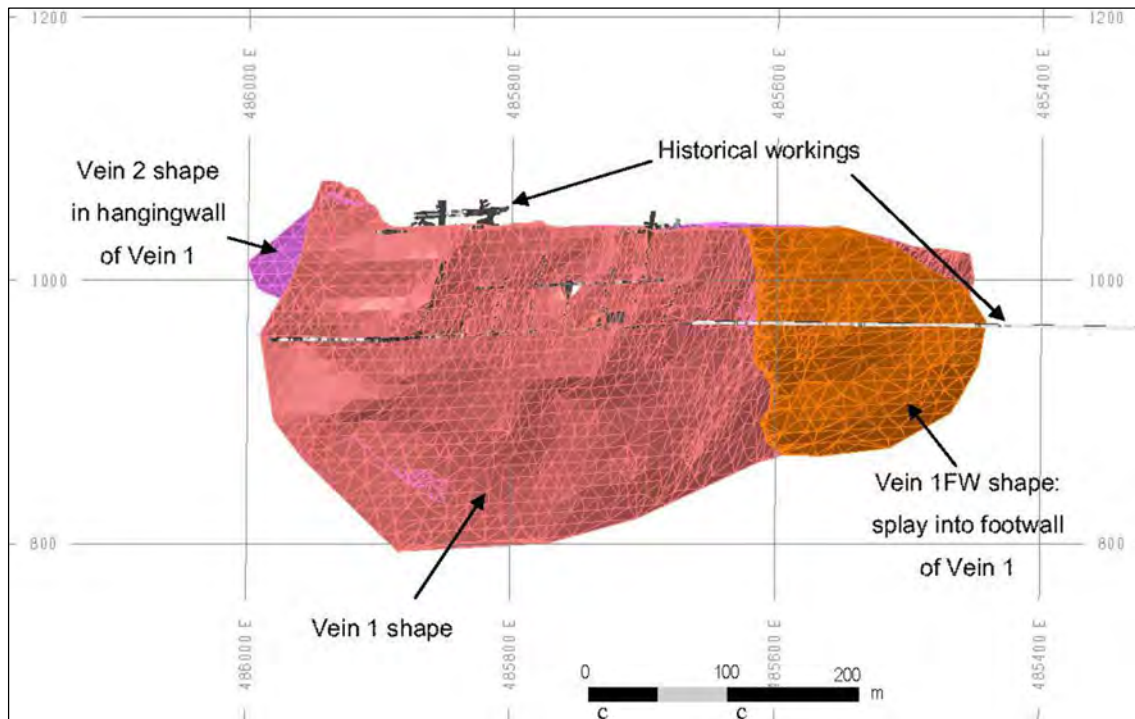

Figure 11-8 – Long Section of Onek Wireframes Looking South (SRK, 2014).

Several weakly mineralized vein fault intercepts were identified in drill holes in the footwall to Vein 1 in the central portion of the deposit, in the vicinity of the historical workings. The continuity of these intercepts could not be established with the information available, and these veins are regarded as small splays off the main Vein 1 structure. These intercepts were not modeled for resource purposes at this time.

Each of the vein shapes were wireframed independently, with a hanging wall surface and a footwall surface constructed using the drill hole intercepts, the shapes of the veins mapped in the levels and raises, and surface pit mapping. Where there was less information available, a contour tool was used to interpolate the vein shape and width every 10 m in elevation and to smooth the vein surface. The vein shapes were extended to approximately 50 m beyond known drilling and given a nominal vein thickness. Veins 2 and 1FW were clipped against the Vein 1 shape. Veins 1 and 1FW were also clipped against the topographic surface that was based on casing depth in nearby diamond drill holes and interpreted overburden depths in proximal historic overburden (rotary) holes.

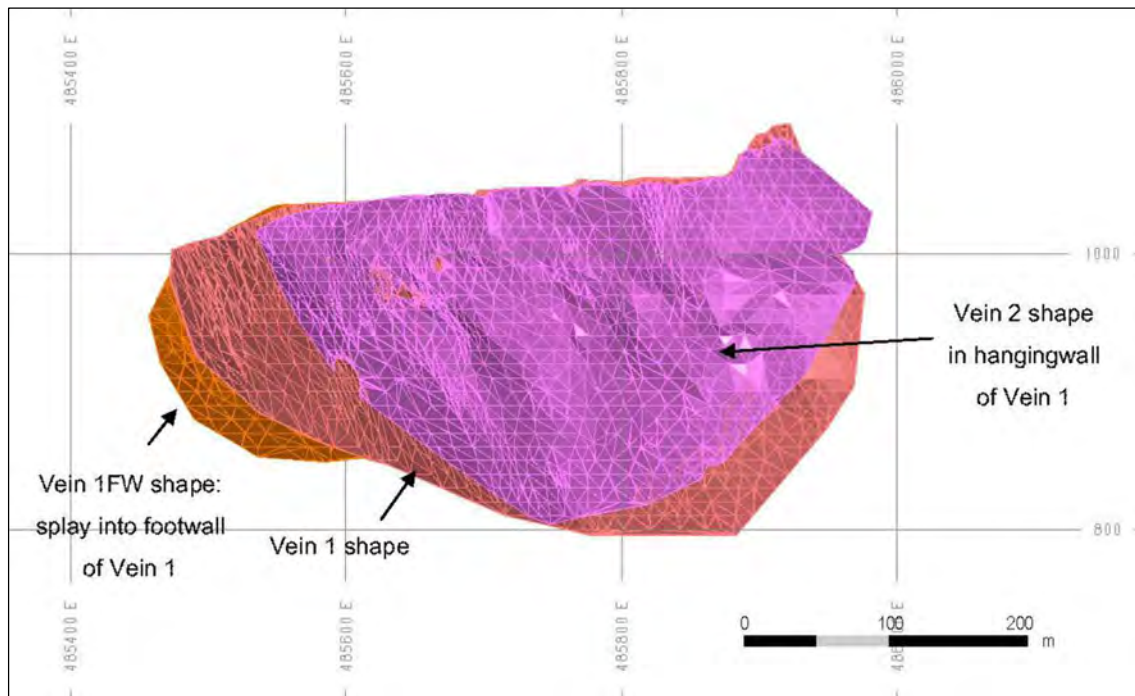

Figure 11-9 – Long Section of Onek Wireframes Looking North (SRK, 2014).

Historical drift and stope mapping were considered to be accurate and representative. Field verification of the mapping could not be performed by geologists because of the current inaccessibility of the underground workings, however; historical maps of other mines in the Keno Hill district have been verified and found to be generally accurate in their representation of the geology. Historical maps were scanned, geo-referenced and imported into MineSight. The images were then draped onto drift solids at the appropriate elevation. This mapping was used to tag hanging wall and footwall contacts on the wireframe. Historical (UKHM) chip sample data were not used to define wireframe contacts or wireframe width.

11.2.2.5 Mineralization Domaining for the Bermingham Deposit

The 4 main vein systems within the Bermingham deposit are known as the Bermingham Main Vein, Bear Vein, Footwall Vein and West Dipper Veins. Three of these vein systems (i.e., Bermingham Main, Bear and Footwall Veins) have a strike orientation of approximately 40° to the northeast and dip to the southeast at approximately 55° to 75°. The West Dipper Veins have a strike orientation between 20° to 40° to the northeast and dip approximately 57° to the northwest. The veins are segregated (and offset) by cross-cutting fault structures into five distinct mineralized zones known as the Etta, Arctic, Bear and Northeast (NE) and Deep Northeast (DNE) zones (Figure 11-10 to Figure 11-12).

The potentially economic mineralization occurs within structural corridors characterized by a damaged zone surrounding the mineralization. The overall structural corridors were initially interpreted by Alexco

using geology and an approximate silver grade threshold of 100 g/t; the interpretation of mineralized vein domains within the structural corridors was based on the presence of discrete and continuous sulfide veins.

The mineralization wireframes for the Birmingham deposit were created using a combination of underground geologic maps and intervals selected from drillholes. Detailed hanging wall and footwall points were placed using geological maps draped within Leapfrog Geo for the Bear Zone. This interpretation was extrapolated to the surrounding drillholes. Arctic, Etta, and NE/DNE zones wireframes were created using the drillhole interval selection tool within Leapfrog Geo. Improvements to the modelling included splitting veins into multiple domains, comprised of vein mineralization and stringer mineralization. The Arctic Zone consists of six distinct domains, with Bear incorporating 13 wireframes, DNE featuring six, Etta comprising four, and NE containing two vein wireframes. This was done to reflect the high variability of mineralogy within the vein fault structures.

The QP reviewed the wireframes relative to the drill hole data supplied by Hecla and concluded the interpretation of the mineralized veins was a reasonable representation of the mineralization system and were of sufficient quality to use for Mineral Resource Estimation.

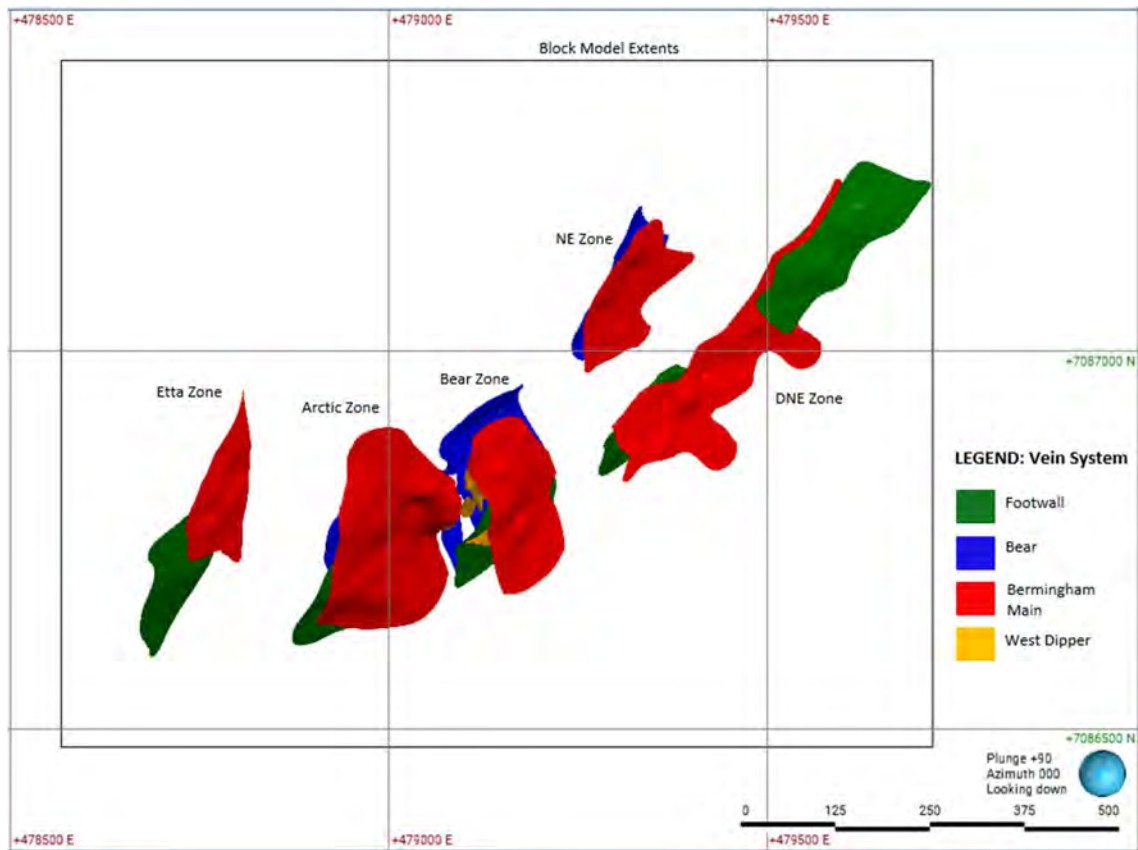

Figure 11-10 – Bermingham Geological Model (Plan View).

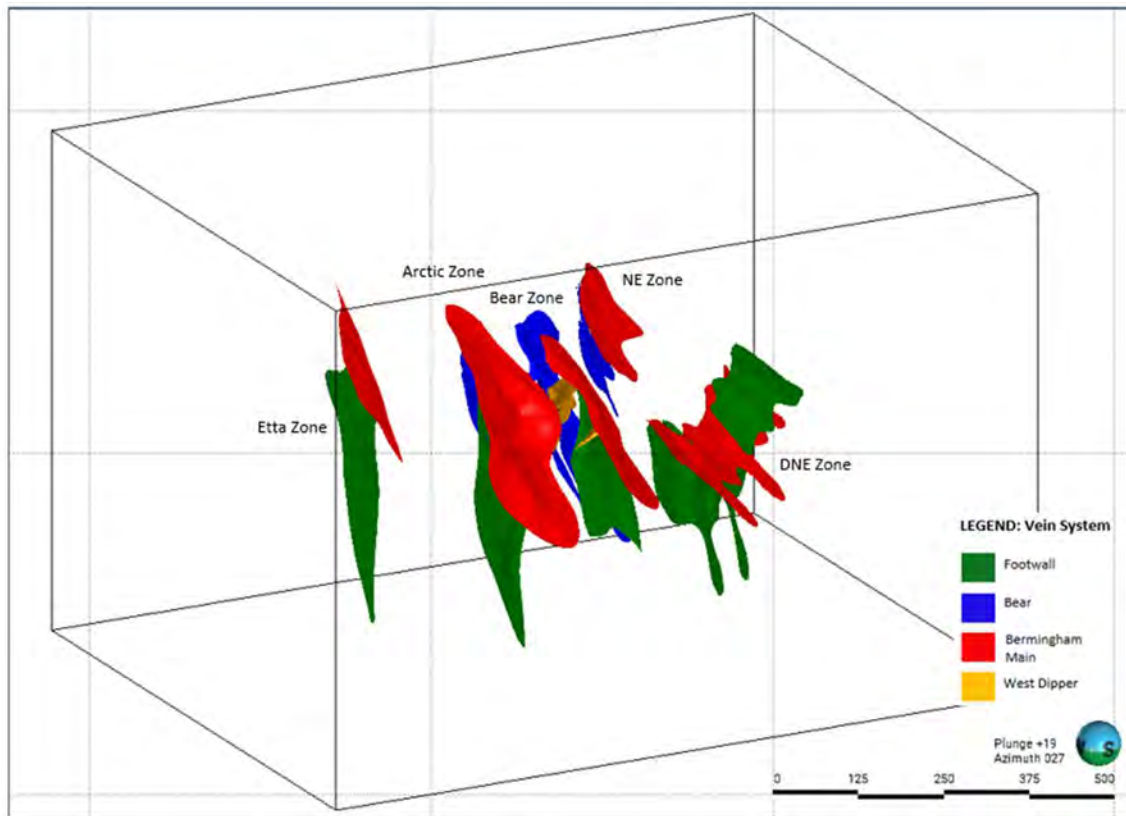

Figure 11-11 – Bermingham Geological Model (3D Oblique View Looking North-East).

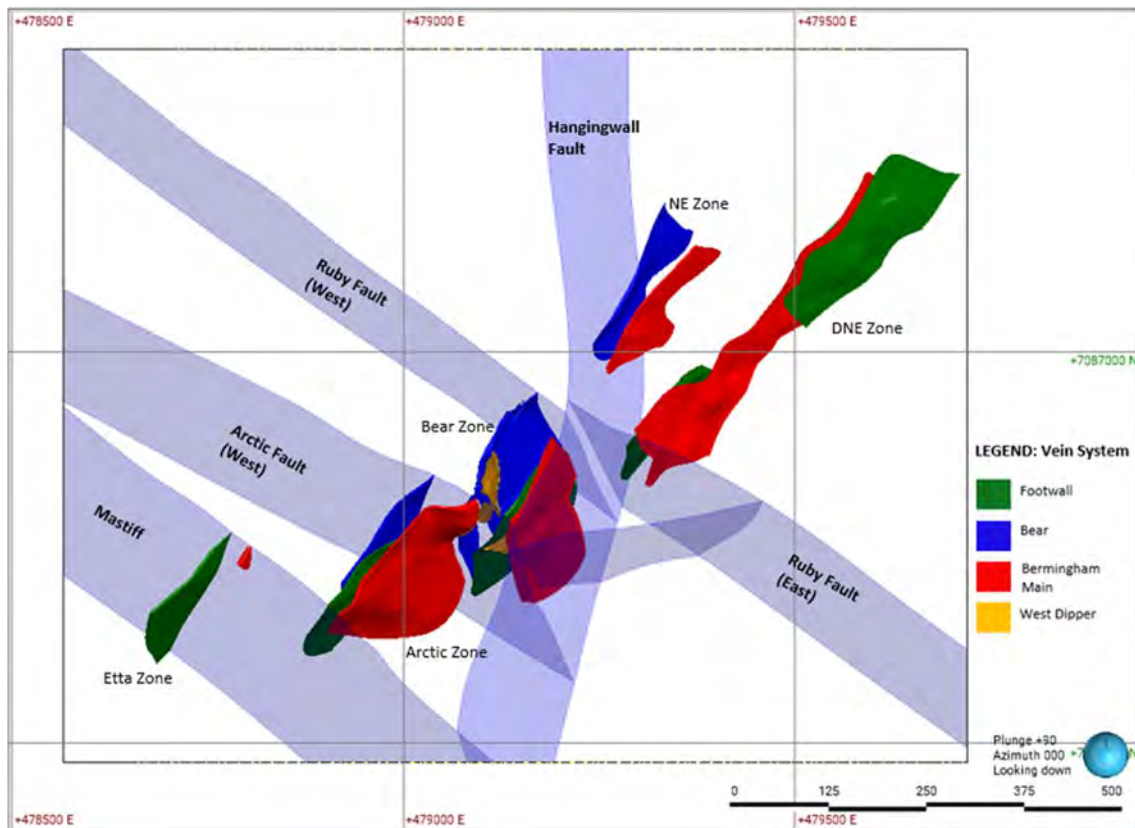

Figure 11-12 – Cross-cutting Faults (Plan View).

11.2.3 BULK DENSITY DATA

11.2.3.1 Bulk Density for the Bellekeno Deposit

Bulk density samples were collected during assay analysis for 1,450 of the core drillhole samples that were coded within the wireframe veins. Pulp bulk density measurements were made by pycnometer at ALS Chemex in Vancouver. An 'All Metal %' value was calculated for each of the silver, lead and zinc values corresponding to these:

$$\text{All Metal \%} = \left[\frac{\text{Ag(ppm)} + \text{Pb(ppm)} + \text{Zn(ppm)}}{10,000} \right]$$

The All Metal % result for each of the samples was then plotted against the density values (Figure 11-13) to determine the polynomial regression formula:

$$\text{Density} = 0.0002(\text{All Metal}\%)^2 + 0.0263(\text{All Metal}\%) + 2.9812$$

Of the comparisons plotted, six were capped at density = 7.0, three were removed during initial sample checks, and two were removed as outliers (Table 11-6).

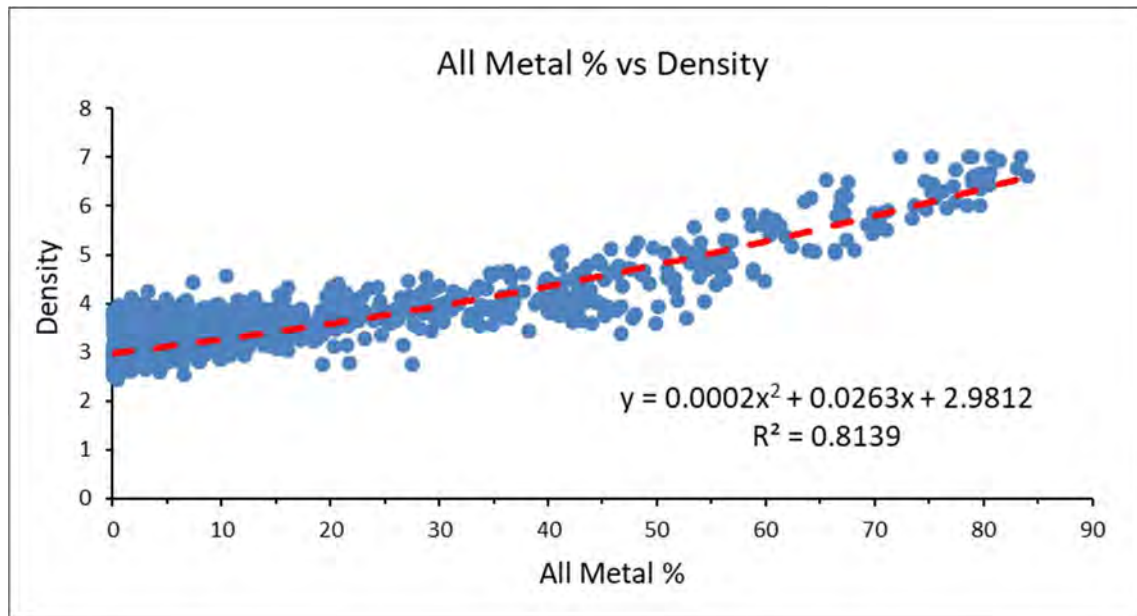

Figure 11-13 – Bulk Density vs. All Metal (%) for Bellekeno (Alexco, 2021b).

Table 11-6 – Bellekeno Bulk Density Measurements (Alexco, 2021b).

Count	Bulk Density Measured on Core			
	Minimum	Maximum	Average	Median
1,445	2.44	7.00	3.40	3.11

The QP acknowledges that pulp measurements will typically result in slightly higher density values of approximately 3% – 5% when compared to measurements taken on core samples as demonstrated on other deposits within the Keno Hill project area. Additional core bulk density measurements should be collected for the Bellekeno deposit to assess the relationship between pulp and core density measurements specific to the Bellekeno deposit. The potential discrepancy in density estimation related to the use of pulp measurements is not considered to be material.

11.2.3.2 Bulk Density for the Lucky Queen Deposit

The bulk density data for Lucky Queen included a total of 191 bulk density measurements (Table 11-7) on core samples. Bulk density was measured by Alexco using a laboratory scale and recording the mass of core pieces in air and in water. The core was not covered by wax or plastic film prior to immersion.

Table 11-7 – Lucky Queen Bulk Density Measurements (Alexco, 2021b).

Count	Bulk Density Measured on Core			
	Minimum	Maximum	Average	Median
191	1.24	6.81	2.74	2.60

Regression analysis of the bulk density measurements shows a moderately strong correlation between the lead assay results and the reported bulk density, with a correlation coefficient of 0.62 (Figure 11-14). Therefore, a linear correlation was used to assign a bulk density value to each block based on the following relationship:

$$\text{Bulk density} = \text{Pb (ppm)} \times 0.00006 + 2.617$$

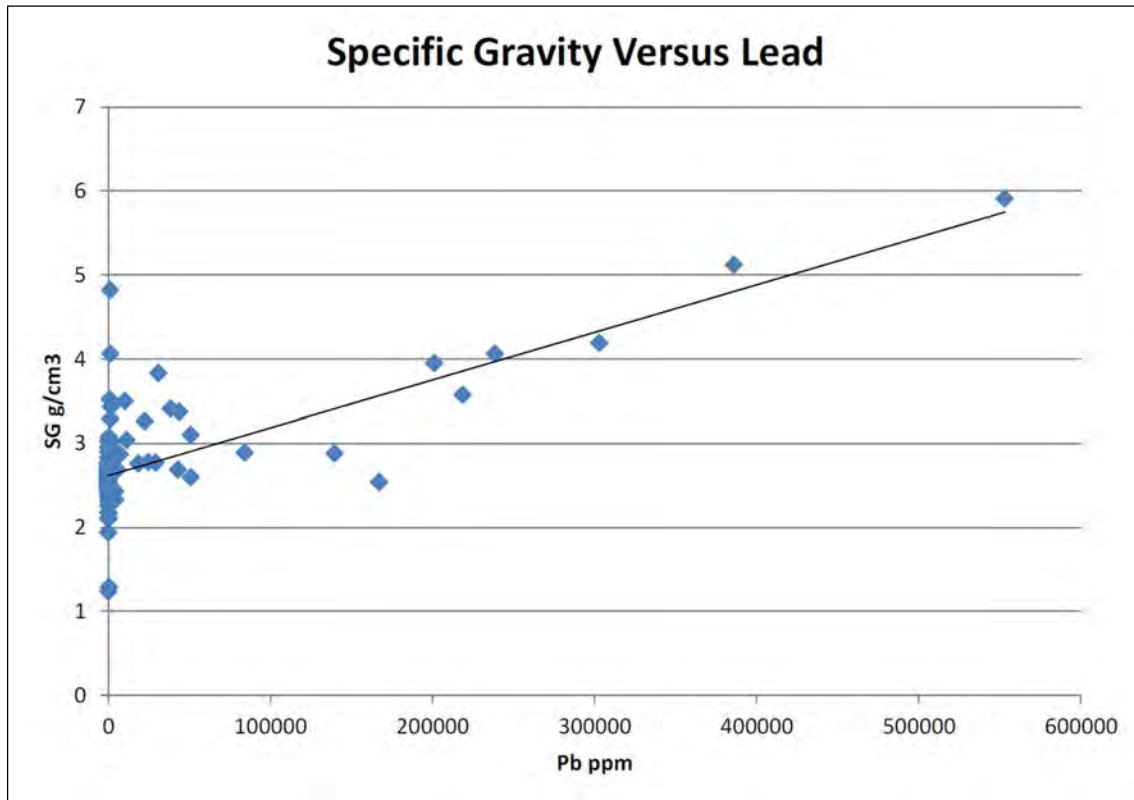

Figure 11-14 – Scatter Plot of Lead Assay Results and Bulk Density Measurements for Lucky Queen (SRK, 2011a).

11.2.3.3 Bulk Density for the Flame and Moth Deposit

The Flame and Moth dataset contained a total of 1,018 bulk density measurements on core samples and 4,189 pulp density measurements. In total, 380 core bulk density and 1,119 pulp density samples existed in the mineralized domains (Table 11-8).

Bulk density was measured on core samples by Hecla using a laboratory scale and recording the mass of core pieces in air and water. Core was not covered by plastic film or wax prior to immersion. Pulp bulk density estimates were conducted by pycnometry at ALS in North Vancouver. A linear regression between core and pulp bulk density measurements has been used to adjust the pulp density values by a factor of 0.957, as shown in Figure 11-15.

For estimates of block SG values, a combination of core bulk density and adjusted pulp density values was used.

Table 11-8 – Flame and Moth Bulk Density Data within Mineralized Domains (Alexco, 2021b).

Domain	Type	Count	Mean	Min	Max
Christal SM	Pulp	27	3.23	2.69	4.20
	Core	10	2.80	2.10	3.20
Christal VM	Pulp	239	3.86	2.53	5.63
	Core	98	3.79	2.60	5.90
Lightning v0	Pulp	77	3.27	2.76	4.91
	Core	25	3.25	2.60	4.30
Lightning v1	Pulp	188	3.52	2.65	5.71
	Core	83	3.40	2.20	5.20
Lightning v2	Pulp	77	3.48	2.73	4.82
	Core	36	3.42	1.90	4.30
Lightning SM	Pulp	511	2.98	2.18	4.77
	Core	128	3.09	1.60	4.40
Total	Pulp	1,119	3.32	2.18	5.71
	Core	380	3.37	1.60	5.90

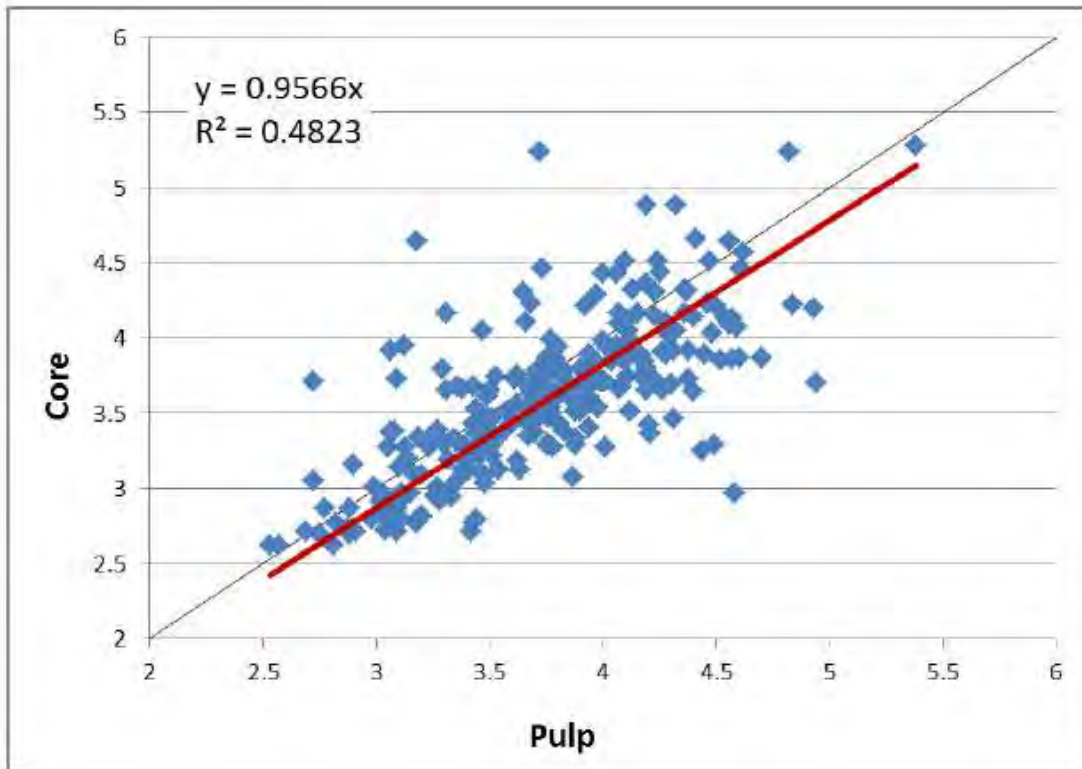

Figure 11-15 – Pulp Versus Core SG Values (RPA, 2017).

While Mining Plus supported the current regime for applying bulk density values to the block model, it recommended the application of the predicted bulk density using Pb and Zn assays followed by assigning an average density if required. This process sequence may support improved local variation in the model. It was also suggested that additional bulk density determinations be conducted in mining areas to provide further confirmation.

11.2.3.4 Bulk Density for the Onek Deposit

The data supplied by Alexco for Onek included a total of 626 bulk density measurements on core samples and 1,549 pulp density measurements. Of the density measurement from core, 182 were from the mineralized veins and of the 1,549 pulp density measurements, 521 were from inside the mineralized veins (Table 11-9).

Table 11-9 – Onek Bulk Density Measurements (Alexco, 2021b).

Vein	Type	Count	Minimum	Maximum	Average	Median
Vein 1	Pulp	385	2.54	4.92	3.44	3.47
	Core	140	2.47	7.32	2.67	3.45
Vein 1FW	Pulp	12	2.25	4.08	3.25	3.22
	Core	1	3.75	3.75	3.75	3.75
Vein 2	Pulp	124	2.59	4.90	3.17	2.96
	Core	41	2.55	5.07	3.28	3.21
All Samples	Pulp	521	2.25	4.92	3.37	3.35
	Core	182	2.47	7.32	3.36	3.42

Bulk density was measured on core samples by Alexco using a laboratory scale and recording the mass of drill hole core pieces in air and water. The drill hole core was not covered by wax or plastic film prior to immersion. Pulp bulk density measurements were measured by pycnometer at ALS Chemex in Vancouver.

A linear regression of the core versus pulp bulk density measurements for samples was calculated, where:

$$\text{Core Bulk Density} = 0.8532 * \text{Pulp Bulk Density} + 0.408$$

The QP evaluated the bulk density data to investigate any relationship between SG and metal content. Figure 11-16 shows the correlation between the bulk density of samples collected from the Onek Veins plotted against lead, zinc, and iron content. The figure indicates a strong positive correlation between bulk density and metal content. For this reason, SRK decided to weight the composites against density as well as length for the resource estimation.

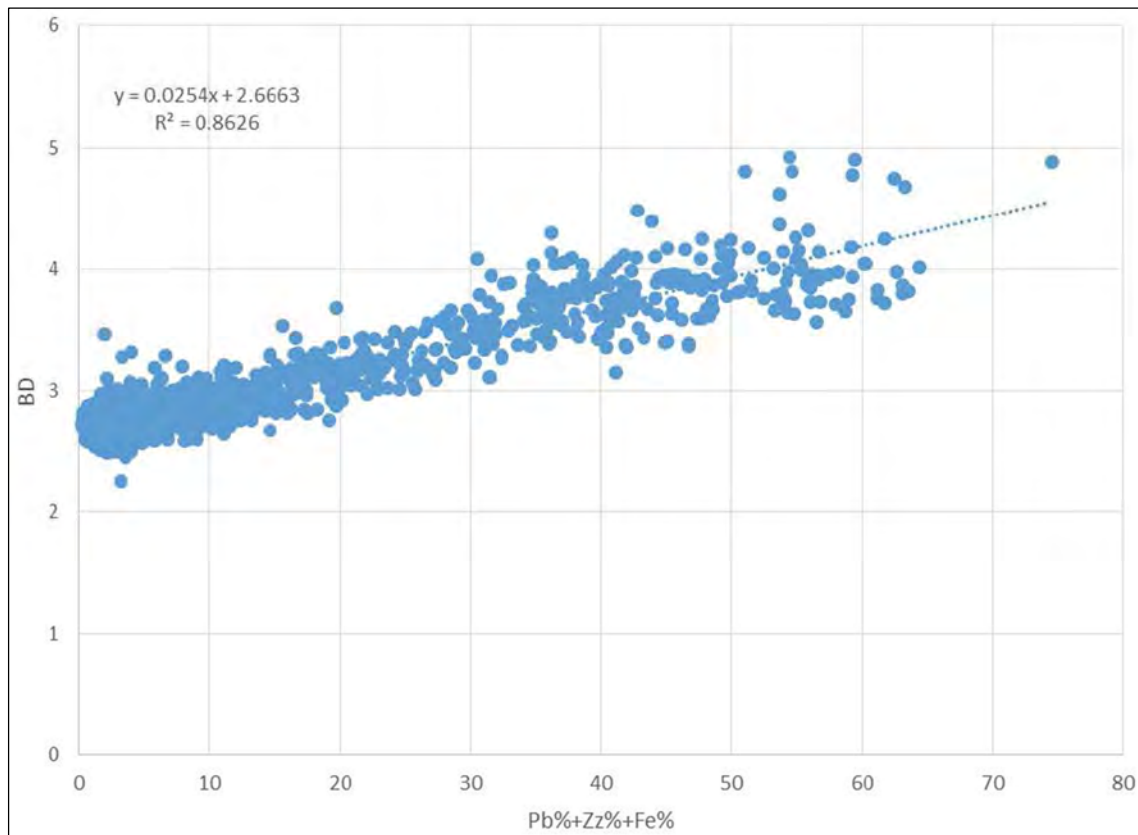

Figure 11-16 – Correlation Between Bulk Density and Metal Content for Onek Veins (RPA, 2017).

There are 633 assay intervals within the veins at Onek containing 703 bulk density measurements. Of the 633 assay intervals, 91 intervals have no density measurements leaving 542 intervals with density measurements and 161 of these intervals contain bulk density measurements from both core and pulp.

For the estimation of bulk density into the block model the QP used core measurements if both core and pulp measurements were present, pulp measurements where core measurements were missing, and calculated bulk density based on the metal content where both core and pulp measurements were absent.

The QP acknowledges that pulp measurements are slightly higher than core density measurements where both sample types are present and that using pulp measurement without correction could lead to a slight (3% to 5%) over estimation of the bulk density (Figure 11-17). However, the QP is of the opinion that the difference is minimal and not material.

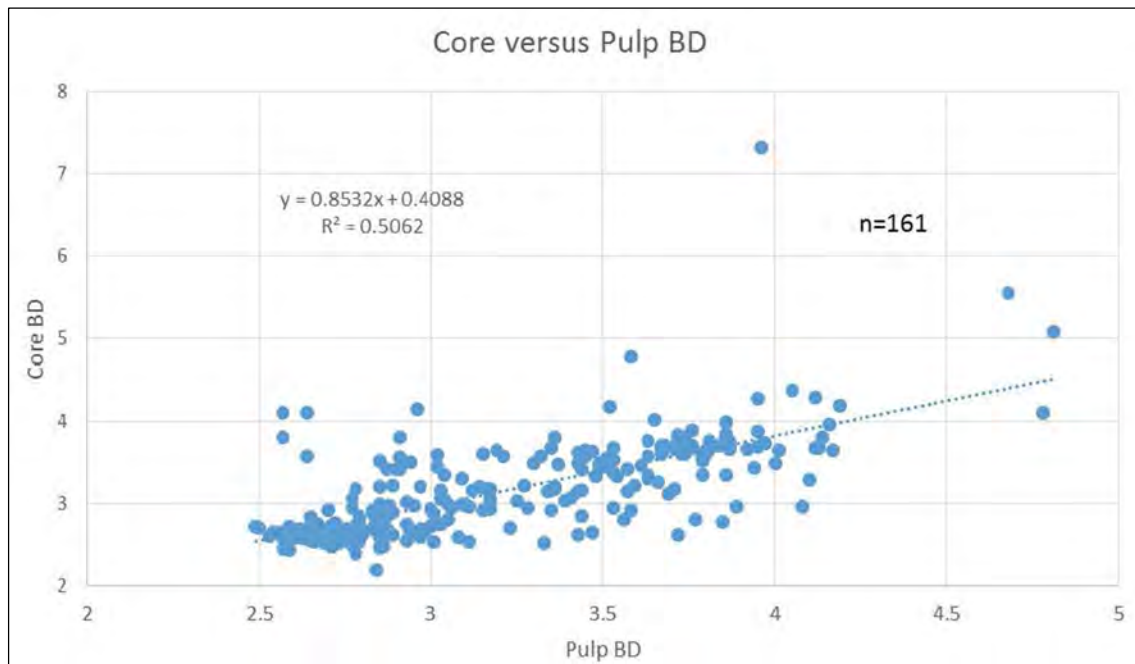

Figure 11-17 – Comparison of Core and Pulp Density Measurements for Onek (RPA, 2017).

11.2.3.5 Bulk Density for the Bermingham Deposit

The Bermingham dataset contains a total of 448 bulk density measurements on core samples and 5,441 pulp density measurements. Of these, 86 bulk density and 1,196 pulp density samples lie within the mineralized domains. Density measurements by zone are summarized in Table 11-10 below.

Bulk density was measured on core samples by Hecla using a laboratory scale and recording the mass of core pieces in air and in water. Core was not covered by plastic film or wax prior to immersion. Pulp bulk density measurements were measured by pycnometry at ALS in North Vancouver. A two-step procedure was developed to infill the missing density values. First an average value by lithology was assigned to those samples missing density measurement. Then a regression formula that considered the Pb% + Zn% was used to calculate a density value that would overwrite these average values. The formula used is as follows:

$$\text{Predicted Core Density} = (0.0372 * (\text{Pb}\% + \text{Zn}\%) + 3.0036) * 0.9852$$

All non-vein blocks were coded with background SG values depending on lithology.

Table 11-10 – Bermingham Bulk Density Measurements (Hecla, 2023f).

Zone	Domain	Type	Count	Mean	
Arctic	FM_sm_1	Core	0	-	
		Pulp	20	3.09	
	BR_sm_1	Core	0	-	
		Pulp	4	2.84	
	BM_sm_1	Core	2	2.94	
		Pulp	21	2.88	
	BM_VF	Core	10	3.52	
		Pulp	79	2.98	
	FW_VF	Core	4	4.50	
		Pulp	54	3.26	
	BR_VF	Core	3	2.76	
		Pulp	35	2.94	
	Bear	BM_sm_1	Core	0	-
			Pulp	3	3.04
BM_VF		Core	4	3.58	
		Pulp	34	3.07	
BR_sm_1		Core	0	-	
		Pulp	18	2.99	
BR_VF		Core	8	2.92	
		Pulp	108	3.23	
BR_HW_sm		Core	0	-	
		Pulp	64	2.86	
FW_sm_1		Core	1	2.75	
		Pulp	13	2.89	
FW_VF		Core	4	3.72	
		Pulp	44	3.06	
BR_s_VF		Core	1	2.99	
		Pulp	21	3.08	
WD2_sm		Core	1	2.66	
		Pulp	3	2.81	
WD2_VF		Core	0	-	
		Pulp	9	2.96	
WD_sm	Core	0	-		
	Pulp	7	2.95		
WD VF	Core	2	3.41		

Zone	Domain	Type	Count	Mean
	WDs_VF	Pulp	31	2.93
		Core	0	-
		Pulp	10	-
North East	BM_sm_1	Core	0	-
		Pulp	15	2.94
	BM_VF	Core	9	2.95
		Pulp	114	2.98
	FW_sm_1	Core	5	2.97
		Pulp	123	2.86
	FW_VF	Core	8	3.11
		Pulp	224	3.16
	BM2_VF	Core	6	3.21
		Pulp	23	2.86
	BR_VF	Core	2	2.65
		Pulp	38	2.94
Etta	BM_sm	Core	0	-
		Pulp	18	2.94
	BM_VF	Core	5	3.17
		Pulp	33	3.10
	FW_sm_1	Core	3	2.68
		Pulp	8	2.80
	FW_VF	Core	8	3.01
		Pulp	22	3.04
All Zones	All Domains	Core	86	3.22
		Pulp	1,196	3.02

11.2.4 COMPOSITING

11.2.4.1 Compositing for the Bellekeno Deposit

Alexco identified a total of 7,057 sample intervals as vein intercepts. Using Hexagon MinePlan Drillhole Manager software, samples were composited to 1.5 m lengths within the defined vein intervals. A histogram of sample lengths for the mineralized zones can be seen in Figure 11-18.

A total of 3,815 composites were derived for the Bellekeno deposit: 2,334 for SW Vein, 1,214 for 99 Vein, and 267 for East Vein. Any composite lengths that were less than 0.75 m were attached to the previous composite length. One percent of total composited lengths remained below 0.35 m and were removed.

A reduced length-weighting factor was applied to all samples less than 1.5 m, and a maximum length-factor of 1.0 was applied to any lengths greater than 1.5 m.

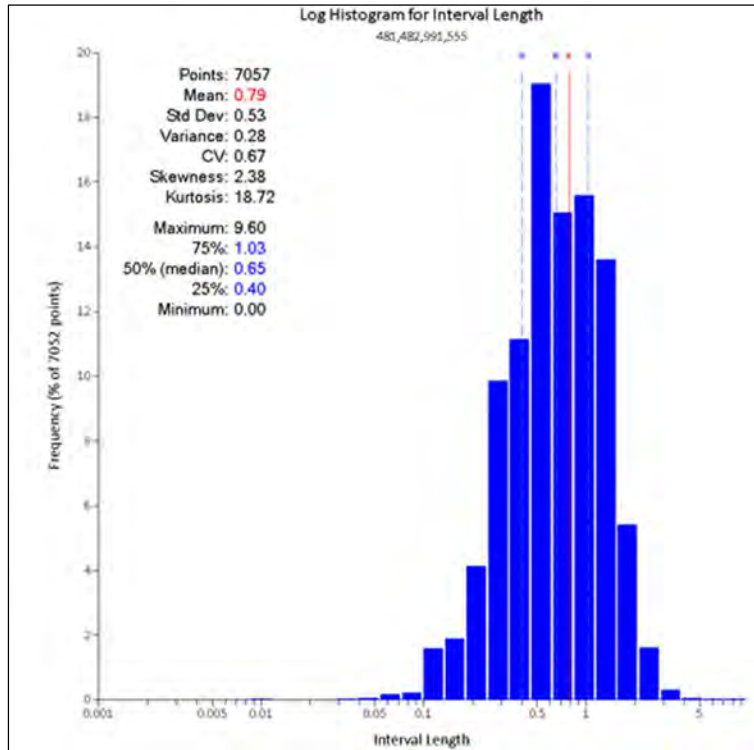

Figure 11-18 – Histogram of Sample Lengths for the Mineralized Zones for Bellekeno Deposit (Alexco, 2021b).

11.2.4.2 Compositing for the Lucky Queen Deposit

Alexco identified a total of 106 core drill hole assay intervals as primary vein intercepts and 26 intervals as secondary splay intercepts. These assay intervals were imported into GEMS, and assays were then composited to one-meter length-weighted intervals within the defined vein wireframes. Terminal composites with a length of less than 50 cm were merged with the preceding composite in order to avoid a short sample bias during estimation. Missing sample intervals were assigned a nominal value of 0.001 during compositing.

11.2.4.3 Compositing for the Flame and Moth Deposit

In the Flame and Moth estimate, raw assays were flagged using the interpreted wireframes and allocated ZONE and VEIN alphanumeric fields. A 1.0 m sample length was selected as the appropriate composite length based on the analysis of sample length versus grade as shown in Figure 11-19. Assays were

composed in 1 m intervals within the mineralized zones and any residual composite length shorter than 0.5 m was distributed equally amongst composites within that domain based on the original sampling lengths. This process resulted in all of the original intervals being composited for use in the estimate and was considered the best method for resource estimation.

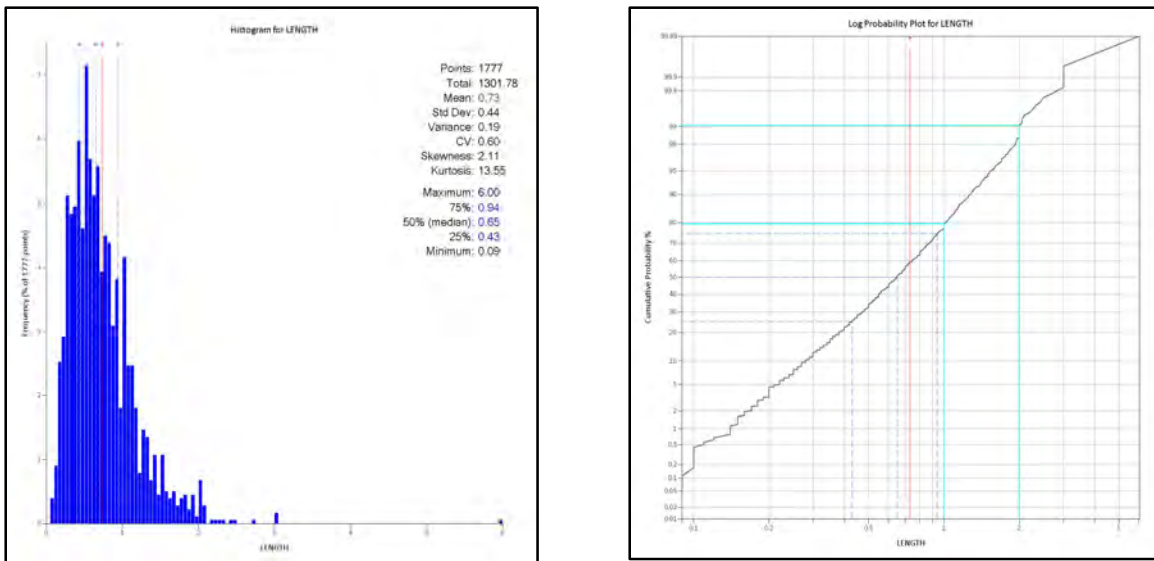

Figure 11-19 – Flame and Moth Compositing Summary – Length.

The NR samples have been set to be omitted for the purposes of the estimate. This process is the Leapfrog software equivalent of the intervals being set to Null values, and for subsequent processes being assumed that they are the statistical equivalent(s) of the nearest actual samples. While this assumes there are sufficient real values adjacent to the omitted samples, this is standard practice for the purposes of statistical analysis and estimation.

11.2.4.4 Compositing for the Onek Deposit

Alexco identified a total of 633 diamond drill hole assay intervals as vein intercepts. These assay intervals were imported into GEMS, and assays were then composited to one-meter length and density-weighted intervals within the defined vein wireframes. A histogram of sample lengths within the mineralized zones can be seen in Figure 11-20.

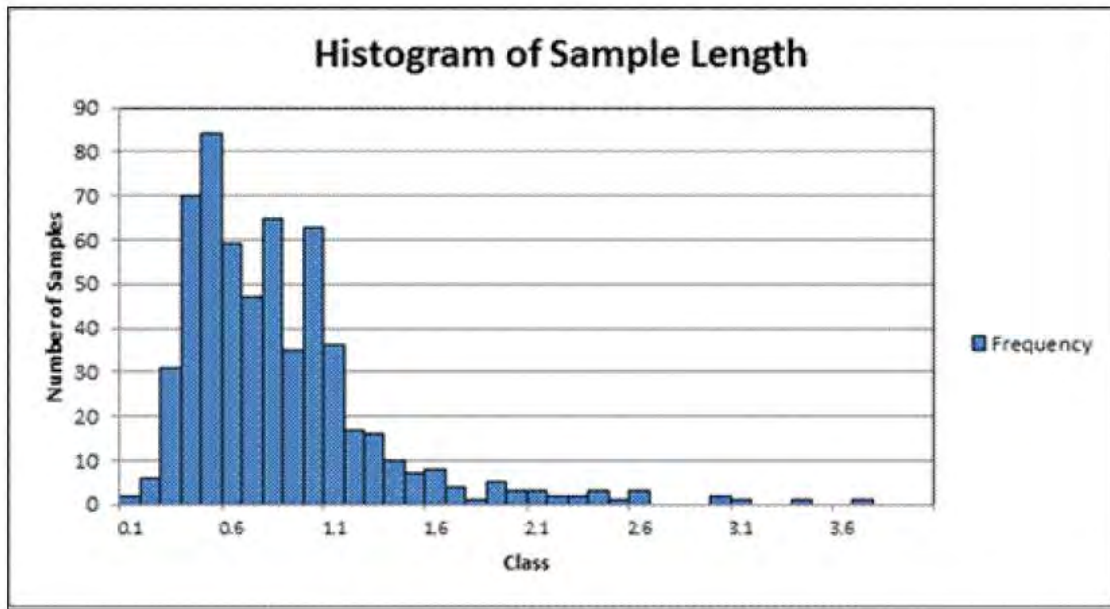

Figure 11-20 – Histogram of Sample Lengths within Onek Veins (RPA, 2017).

11.2.4.5 Compositing for the Bermingham Deposit

A target composite interval length of 1 m was selected for Bermingham based on the average raw assay sample length being 1.37 m, and approximately 38 % of mineralized assay samples consisting of sample lengths of less than 1 m (Figure 11-21). Wireframes of the mineralized veins were used to constrain assay data compositing with any residual composite lengths shorter than 0.5 m added to the previous interval within that domain. Intervals with missing sample data recorded as “NR” due to core loss were ignored during data compositing.

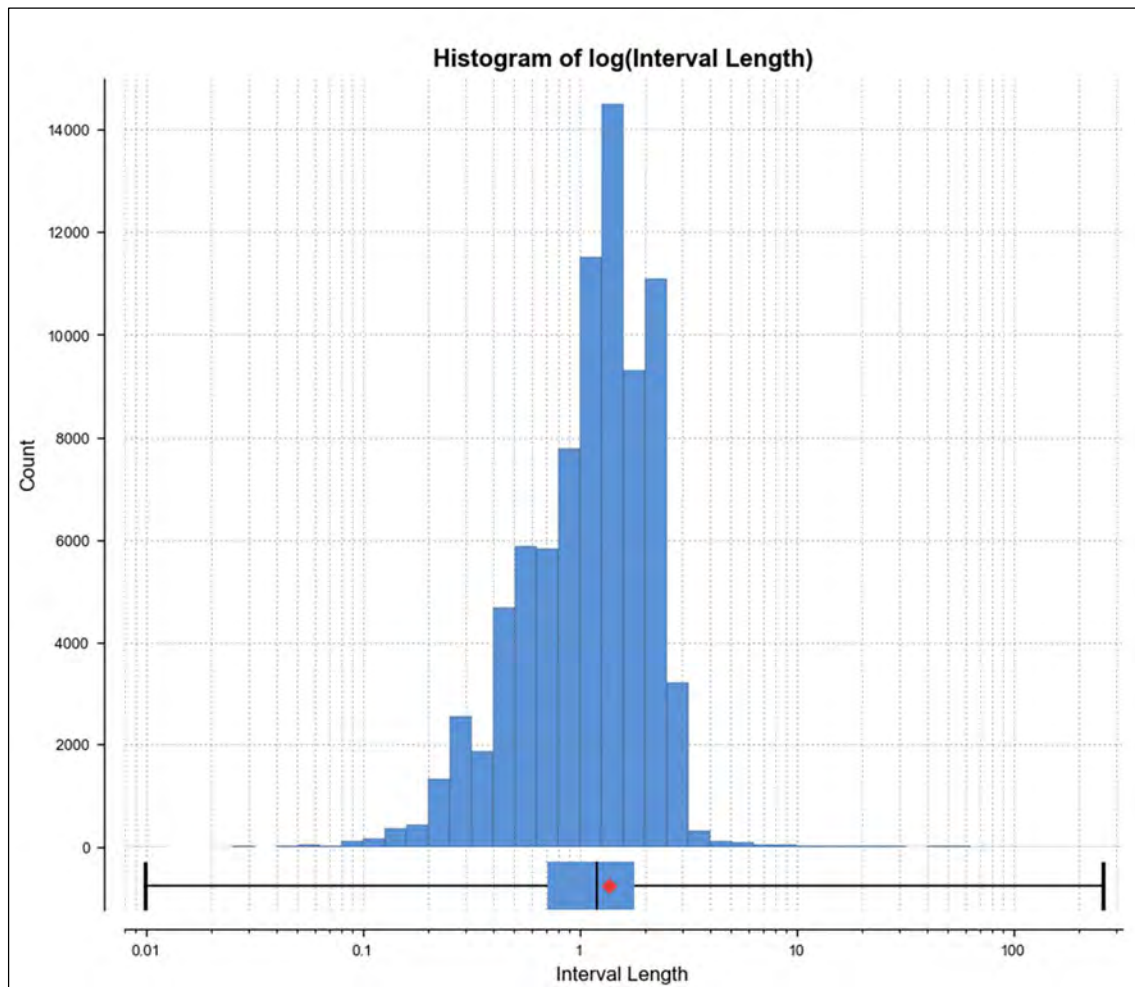

Figure 11-21 – Histogram of Sample Lengths for the Mineralized Zones for Bermingham Deposit.

11.2.5 OUTLIER ANALYSIS AND CAPPING

11.2.5.1 Outlier Analysis and Capping for the Bellekeno Deposit

Grade capping analysis was conducted on the domain-coded composited assay data to limit the influence of extreme assay values during estimation. The assay composites were examined using histograms and cumulative frequency plots for each commodity in each vein. A summary table of the selected capping thresholds and corresponding impacts on average grade and metal loss is provided in Table 11-11. This capping threshold value was selected to minimize changes in the sample distribution. Composites were capped prior to estimation.

It should be noted that the East Main and East Splay veins were assessed as one data population due to the limited number of data in both veins.

Table 11-11 – Composite Capping Levels for the Bellekeno Deposit (Alexco, 2021b).

Vein	Commodity	Maximum Value	Cap Value	Number Capped	Average Grade (Uncapped)	Average Grade (Capped)	Lost Metal*
Southwest Vein	Ag (g/t)	9,832	4,500	21	852	839	1.5%
	Pb %	83.51	65	25	10.73	10.65	0.7%
	Zn %	46.67	33	26	6.87	6.82	0.8%
99 Vein	Ag (g/t)	19,450	7,600	6	1,118	1,103	1.3%
	Pb %	73.36	55	13	7.08	6.98	1.4%
	Zn %	45.22	20	23	3.53	3.41	3.3%
East Vein (Main and Splay)	Ag (g/t)	4,790	2,000	9	282	247	12.4%
	Pb %	38.40	15	6	1.48	1.22	17.4%
	Zn %	49.16	20	11	3.37	2.94	12.9%

* Lost metal is (Average - Average Capped)/Average*100 where Average is the average grade for the assays before capping and Average Capped is the average grade of the assays after capping.

11.2.5.2 Outlier Analysis and Capping for the Lucky Queen Deposit

Grade capping analysis was conducted on the domain-coded and composited data to limit the influence of extreme assay values during estimation. The combined composite sample population for the main Lucky Queen vein and splay was examined using histograms, probability graphs, and capping plots. Capping threshold values were selected to minimize changes in the sample distribution, and sample values were capped to these values prior to compositing and estimation (Table 11-12). For lead, the capping threshold was set to the percentile used for grade capping of silver to maintain the observed correlation between these two elements.

Table 11-12 – Composite Capping Levels for Lucky Queen (Alexco, 2021b).

Commodity	Maximum Value	Cap Value	Mean	Mean Capped	Number Capped	Lost Metal*
Ag (g/t)	13,998	6,300	960	834	2	13.1%
Au (g/t)	3.00	2.00	0.16	0.15	1	10.0%
Pb (ppm)	303,963	148,000	20,831	18,461	2	11.4%
Zn (ppm)	210,100	70,000	13,944	10,143	3	27.2%

* Lost metal is (Average - Average Capped)/Average*100 where Average is the average grade for the assays before capping and Average Capped is the average grade of the assays after capping.

11.2.5.3 Outlier Analysis and Capping for the Flame and Moth Deposit

Within the assay population, outliers were evaluated by Hecla and capping levels were established for some veins which revealed some skewed behavior between the global mean and local estimates relative to a Nearest Neighbor (NN) derived estimate. In response to this, the traditional capping of samples was

dismissed in favor of a distance-based clamping (value clipping in Leapfrog) of Ag values during estimates. This method was only applied to elevated silver assays and the capping was not used for estimation of other metals.

Applied distances as a percentage of the search pass and grade thresholds are outlined in Table 11-13.

Table 11-13 - Outlier Restriction in the Flame and Moth Deposit for Ag (Hecla, 2023e).

Zone	Domain	Search Pass	Method of Outlier Restriction in Leapfrog	Distance %	Threshold
Lightning	v0	1	Clamp	25	2,000
Lightning	v0	2	Clamp	12.5	2,000
Lightning	v1	1	Clamp	25	2,000
Lightning	v1	2	Clamp	12.5	2,000
Christal	vm	1	Clamp	25	2,750
Christal	vm	2	Clamp	12.5	2,750

Mining Plus noted that the Flame and Moth deposit is known to include elevated grade values and additional care is advised when applying any cuts to the population to avoid substantially reducing the contained metal content. A more appropriate method may be to apply a top cut, in addition to a capping threshold.

Mining Plus considered that to avoid severely cutting the amount of metal, it recommended a combination of the cut at 3,000 g/t and a cap at 1,525 with a range determined by either geological mapping or an indicative range calculated by the variograms first (short range) structure.

11.2.5.4 Outlier Analysis and Capping for the Onek Deposit

Before compositing, grade capping analysis was conducted on the domain-coded sample assay data to limit the influence of extreme assay values during estimation. The assays from Vein 1 and Vein 1FW and, separately, the assays from Vein 2 were examined using histograms, and cumulative frequency plots. Capping threshold values were selected to minimize changes in the sample distribution, and sample values were capped to these values prior to compositing and estimation (Table 11-14).

Table 11-14 – Sample Capping Levels for Onek (Alexco, 2021b).

Vein	Commodity	Maximum Value	Cap Value	Number Capped	Average Grade (Uncapped)	Average Grade (Capped)	Lost Metal*
Vein 1 and Vein 1 FW	Ag (g/t)	3,440	3,000	2	210	208	0.7%
	Au (g/t)	10.20	5	4	0.65	0.63	4.8%
	Pb %	48.36	35	2	1.61	1.57	2.5%
	Zn %	55.92	35	56	13.36	12.46	7.3%
Vein 2	Ag (g/t)	4,080	3,000	4	238	221.00	7.8%
	Au (g/t)	3.10	2	1	0.33	0.32	2.3%
	Pb %	46.13	25	4	2.08	1.90	16.3%
	Zn %	40.45	20	4	4.48	4.22	6.1%

* Lost metal is (Average - Average Capped)/Average*100 where Average is the average grade for the assays before capping and Average Capped is the average grade of the assays after capping.

11.2.5.5 Outlier Analysis and Capping for the Bermingham Deposit

Grade capping analysis was conducted on raw sample data to limit the influence of extreme assay values during estimation. The raw samples from the Bermingham veins were examined by reviewing probability plots and evaluating the samples for each domain. Table 11-15 to Table 11-18 illustrate total samples, capping value for each metal and number of samples capped.

Table 11-15 – Sample Capping Levels for Bermingham Arctic Zone (Hecla, 2023f).

Zone	Domain	Metal (ppm)	Total Nr of Samples	Capping Value	Nr of Samples Capped	Percentile
Arctic	BM_sm_1	Ag	47	193	6	87%
		Au	40	0.23	1	98%
		Pb	47	14,800	1	98%
		Zn	47	38,900	2	96%
	BM_VF	Ag	162	none	-	-
		Au	156	none	-	-
		Pb	162	106,500	12	93%
		Zn	162	127,000	7	96%
	BR_sm_1	Ag	11	none	-	-
		Au	11	0.08	1	91%
		Pb	11	15,500	1	91%
		Zn	11	8,810	2	82%
	BR_VF	Ag	53	1,745	2	96%
		Au	47	none	-	-
		Pb	53	none	-	-

Zone	Domain	Metal (ppm)	Total Nr of Samples	Capping Value	Nr of Samples Capped	Percentile
	FW_sm_1	Zn	53	none	-	-
		Ag	28	350	1	96%
		Au	28	0.13	2	93%
		Pb	28	10,500	2	93%
		Zn	28	9,910	2	93%
	FW_VF	Ag	94	5,190	8	91%
		Au	94	0.76	3	97%
		Pb	94	none	-	-
		Zn	94	120,500	3	97%

Table 11-16 – Sample Capping Levels for Birmingham Bear Zone (Hecla, 2023f).

Zone	Domain	Metal (ppm)	Total Nr of Samples	Capping Value	Nr of Samples Capped	Percentile
Bear	BM_sm_1	Ag	4	none	-	-
		Au	4	none	-	-
		Pb	4	none	-	-
		Zn	4	none	-	-
	BM_VF	Ag	86	none	-	-
		Au	86	1.64	1	99%
		Pb	86	55,700	7	92%
		Zn	86	none	-	-
	BR_HW_sm	Ag	125	928	5	96%
		Au	120	0.08	22	82%
		Pb	125	18,300	7	94%
		Zn	125	23,000	8	94%
	BR_s_VF	Ag	39	11,183	2	95%
		Au	39	1.30	4	90%
		Pb	39	477,800	2	95%
		Zn	39	139,000	1	97%
	BR_sm_1	Ag	24	4,200	1	96%
		Au	24	0.08	9	63%
		Pb	24	15,500	11	54%
		Zn	24	139,000	1	96%
BR_VF	Ag	267	11,857	16	94%	
	Au	261	1.35	12	95%	
	Pb	267	none	-	-	
	Zn	267	175,500	2	99%	

Zone	Domain	Metal (ppm)	Total Nr of Samples	Capping Value	Nr of Samples Capped	Percentile
	FW_sm_1	Ag	23	none	-	-
		Au	23	0.34	1	96%
		Pb	23	37,200	1	96%
		Zn	23	none	-	-
	FW_VF	Ag	103	11,406.50	1	99%
		Au	103	none	-	-
		Pb	103	314,200	3	97%
		Zn	103	243,000	2	98%
	WD2_sm	Ag	5	none	-	-
		Au	5	none	-	-
		Pb	5	none	-	-
		Zn	5	none	-	-
	WD2_VF	Ag	16	none	-	-
		Au	16	none	-	-
		Pb	16	none	-	-
		Zn	16	none	-	-
	WD_sm	Ag	11	none	-	-
		Au	11	none	-	-
		Pb	11	none	-	-
		Zn	11	68,000	1	91%
WD_VF	Ag	47	none	-	-	
	Au	47	none	-	-	
	Pb	47	82,400	3	94%	
	Zn	47	145,500	2	96%	
WDs_VF	Ag	13	none	-	-	
	Au	13	none	-	-	
	Pb	13	none	-	-	
	Zn	13	none	-	-	

Table 11-17 – Sample Capping Levels for Bermingham North-East Zone (Hecla, 2023f).

Zone	Domain	Metal (ppm)	Total Nr of Samples	Capping Value	Nr of Samples Capped	Percentile
NE	BM2_VF	Ag	59	none	-	-
		Au	59	none	-	-
		Pb	59	108,000	3	95%
		Zn	59	121,000	3	95%
	BM_sm_1	Ag	17	133	4	76%

Zone	Domain	Metal (ppm)	Total Nr of Samples	Capping Value	Nr of Samples Capped	Percentile
		Au	17	0.29	3	82%
		Pb	17	23,300	1	94%
		Zn	17	33,200	2	88%
	BM_VF	Ag	199	7,430	7	96%
		Au	199	none	-	-
		Pb	199	222,100	11	94%
		Zn	199	116,500	8	96%
	FW_sm_1	Ag	176	385	7	96%
		Au	176	0.34	2	99%
		Pb	176	34,200	1	99%
		Zn	176	39,600	7	96%
	FW_VF	Ag	376	16,367	8	98%
		Au	376	2.18	7	98%
		Pb	376	397,300	11	97%
		Zn	376	203,000	3	99%
	BR_VF	Ag	55	5,890	2	96%
		Au	55	0.59	2	96%
		Pb	55	none	-	-
		Zn	55	94,300	3	95%

Table 11-18 – Sample Capping Levels for Bermingham Etta Zone (Hecla, 2023f).

Zone	Domain	Metal (ppm)	Total Nr of Samples	Capping Value	Nr of Samples Capped	Percentile
Etta	BM_sm_1	Ag	22	none	-	-
		Au	22	none	-	-
		Pb	22	none	-	-
		Zn	22	none	-	-
	BM_VF	Ag	63	none	-	-
		Au	63	none	-	-
		Pb	63	none	-	-
		Zn	63	none	-	-
	FW_sm_1	Ag	18	none	-	-
		Au	18	none	-	-
		Pb	18	none	-	-
		Zn	18	none	-	-
	FW_VF	Ag	47	1,235	6	87%
		Au	47	0.22	4	91%

Zone	Domain	Metal (ppm)	Total Nr of Samples	Capping Value	Nr of Samples Capped	Percentile
		Pb	47	71,400	4	91%
		Zn	47	62,200	4	91%

11.2.6 STATISTICAL ANALYSIS AND VARIOGRAPHY

11.2.6.1 Statistical Analysis and Variography for the Bellekeno Deposit

Examination of the drill hole and chip assay sample data determined that there was a bias in the chip sample dataset as seen in Figure 11-22. To correct for this bias, a weight of 0.7 was applied to all chip data, while drillhole data remained at 1.0. Summary statistics for the final composite data set used for Mineral Resource estimation are provided in Table 11-19.

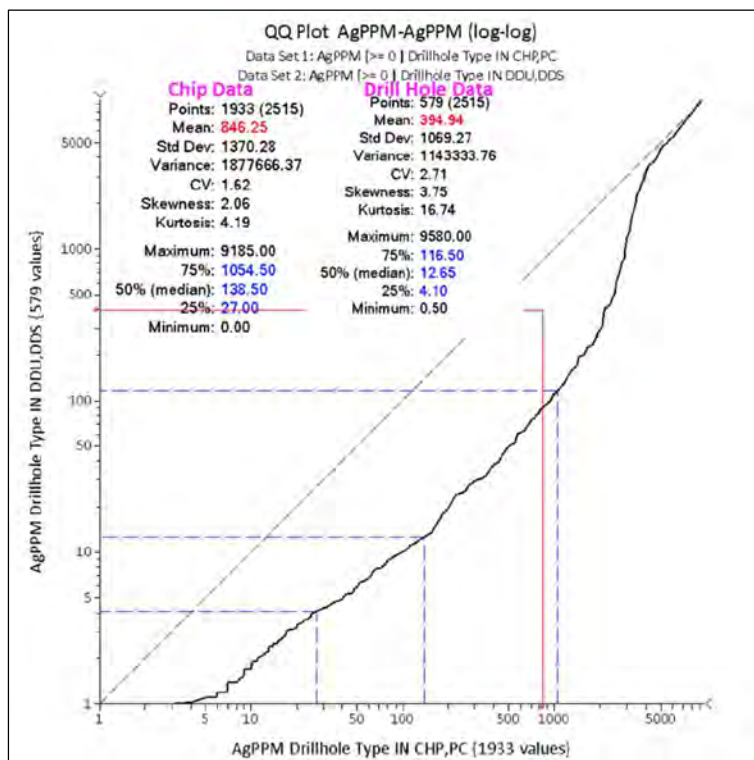

Figure 11-22 – Quantile-Quantile Plot of Silver Values in Drillhole vs. Chip Samples Coded to Bellekeno Veins (SRK, 2021).

Table 11-19 – Summary Statistics for Bellekeno Composited and Weighted Data (Alexco, 2021b).

Vein	Statistic	Ag (g/t)	Pb (%)	Zn (%)
SW Vein	Number of Samples	2,334	2,334	2,334
	Average before weight applied	839	10.65	6.84
	Average after weight applied	559	7.11	4.61
	Minimum	0	0	0
	Maximum	4,500	65	33
	Coefficient of Variation	1.30	1.50	1.10
99 Vein	Number of Samples	1,214	1,214	1,214
	Average before weight applied	1,103	6.98	3.41
	Average after weight applied	750	4.84	2.48
	Minimum	0	0	0.00
	Maximum	7,600	55	20
	Coefficient of Variation	1.90	1.80	1.40
East Vein	Number of Samples	267	267	267
	Average before weight applied	247	1.22	2.94
	Average after weight applied	210	1.05	2.41
	Minimum	0	0	44.00
	Maximum	2,000	15	20
	Coefficient of Variation	2.00	2.70	1.90

Continuity analysis (i.e., variogram analysis) for the Bellekeno data was analyzed by zone and variogram parameters are summarized in Table 11-20. Each element was assessed using a normal score variogram that was back transformed prior to estimation.

Table 11-20 – Summary of Variography for Bellekeno (Alexco, 2021b).

Vein	Metal	Nugget C ₀	Sill	MinePlan Rotations			Ranges a ₁ , a ₂		
			C ₁ , C ₂	around Z	around X	around Y	X-Rot	Y-Rot	Z-Rot
SW	Ag	0.13	0.28	-165°	-33°	66°	15	10	5
			0.59				45	30	10
	Pb	0.17	0.38				10	5	5
			0.45				40	25	10
	Zn	0.11	0.61				5	5	5
			0.28				60	40	10
99	Ag	0.13	0.55	-155°	-44°	76°	7	5	5
			0.32				30	25	10

Vein	Metal	Nugget C ₀	Sill	MinePlan Rotations			Ranges a1, a2		
			C ₁ , C ₂	around Z	around X	around Y	X-Rot	Y-Rot	Z-Rot
	Pb	0.14	0.48				5	5	4
			0.38				30	25	10
	Zn	0.13	0.52				15	15	5
			0.35				100	30	10
East	Ag	0.17	0.39	-172°	-46°	61°	15	10	5
			0.45				45	30	10
	Pb	0.20	0.54				10	5	5
			0.26				40	25	10
	Zn	0.17	0.19				5	5	5
			0.65				60	40	10

11.2.6.1.1 Southwest Zone Variograms

Figure 11-23 to Figure 11-25 present the results for the SW zone normal score variograms for silver, lead and zinc.

In general, it is noted that reasonable variograms are obtained in normal score for silver, lead, and zinc, with a directional range of approximately 45 m to 60 m in the plane of the vein.

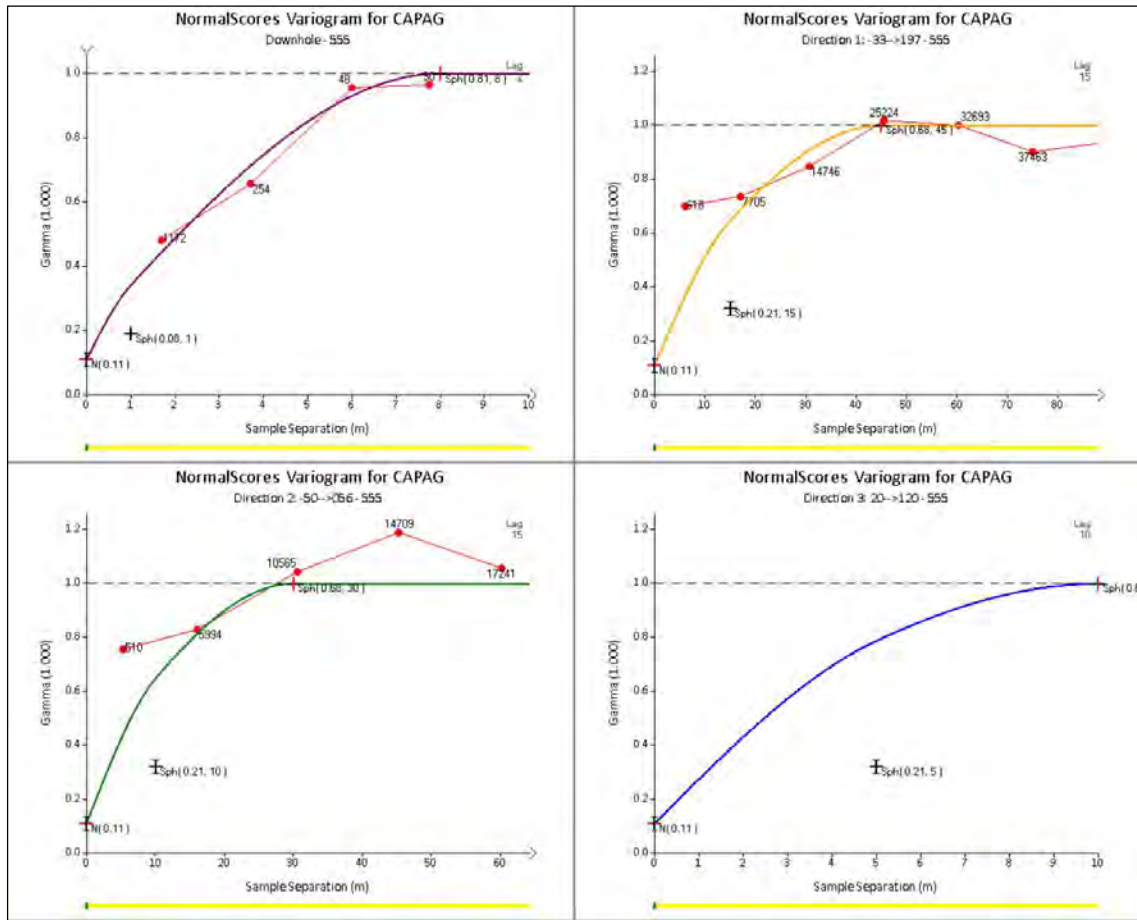

Figure 11-23 – Normal Score Variograms for Capped Silver, Southwest Zone (Alexco, 2021b).

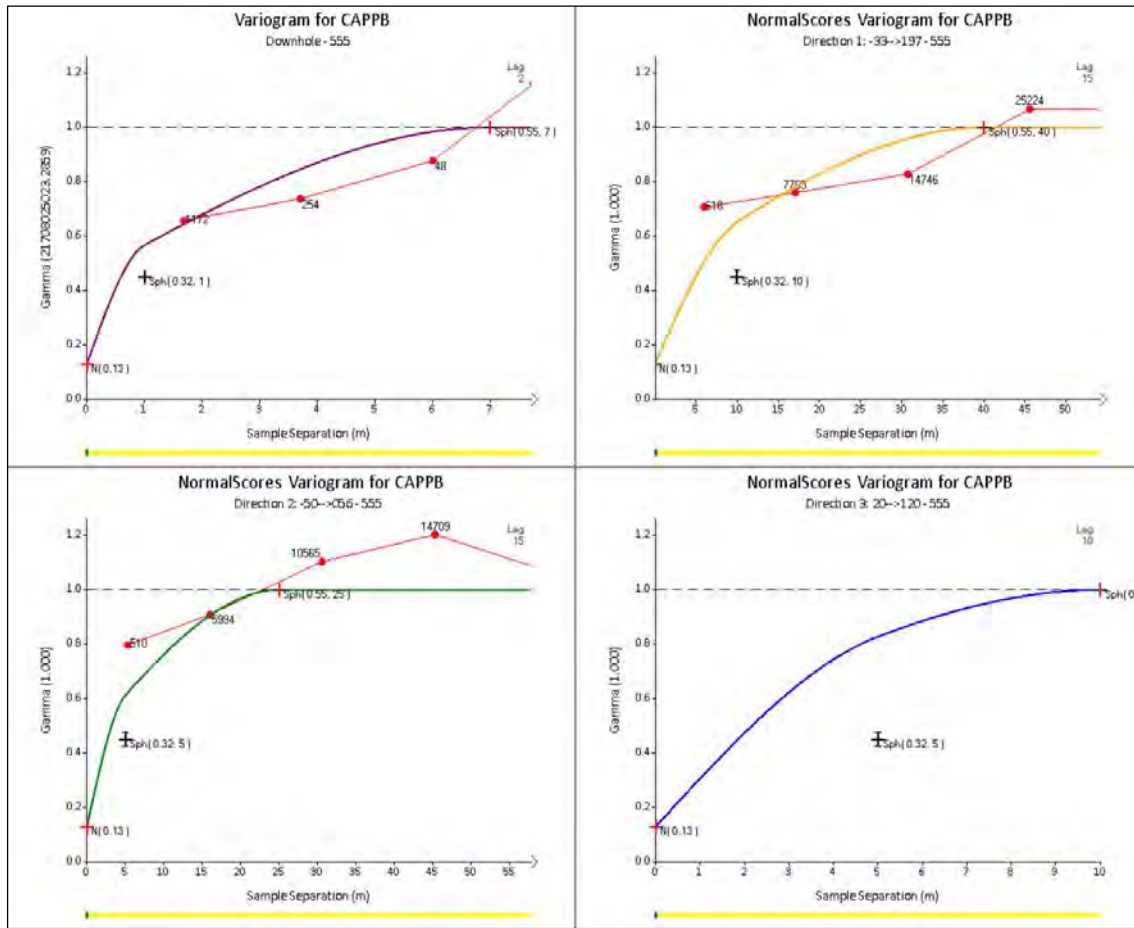

Figure 11-24 – Normal Score Variograms for Capped Lead, Southwest Zone (Alexco, 2021b).

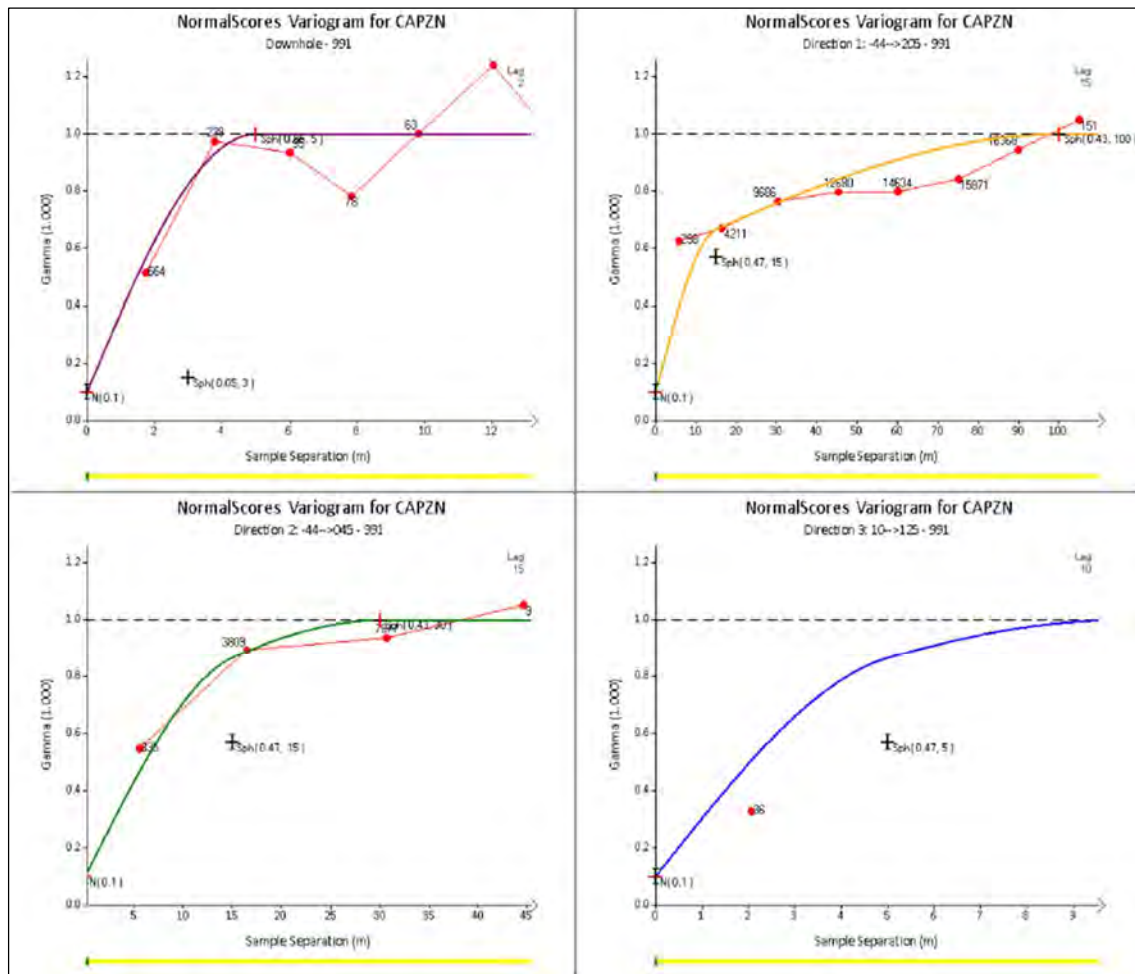

Figure 11-25 – Normal Score Variograms for Capped Zinc, Southwest Zone (Alexco, 2021b).

11.2.6.1.2 The 99 Zone Variograms

Figure 11-26 to Figure 11-28 present results for the SW zone normal score variograms for silver, lead, and zinc.

In general, it is noted that reasonable variograms were obtained in log space for silver, lead, and zinc, with a directional range of approximately 40 m to 70 m in the plane of the vein.

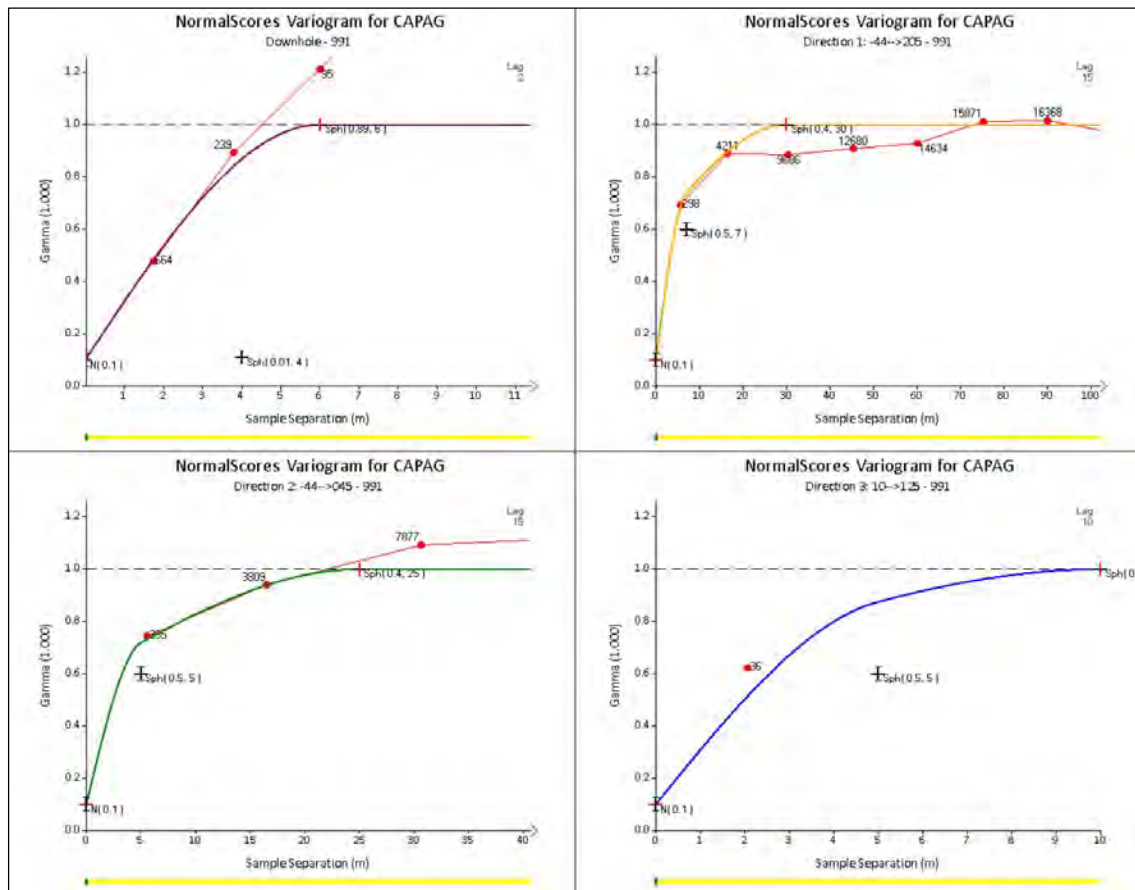

Figure 11-26 – Normal Score Variograms for Capped Silver, 99 Zone (Alexco, 2021b).

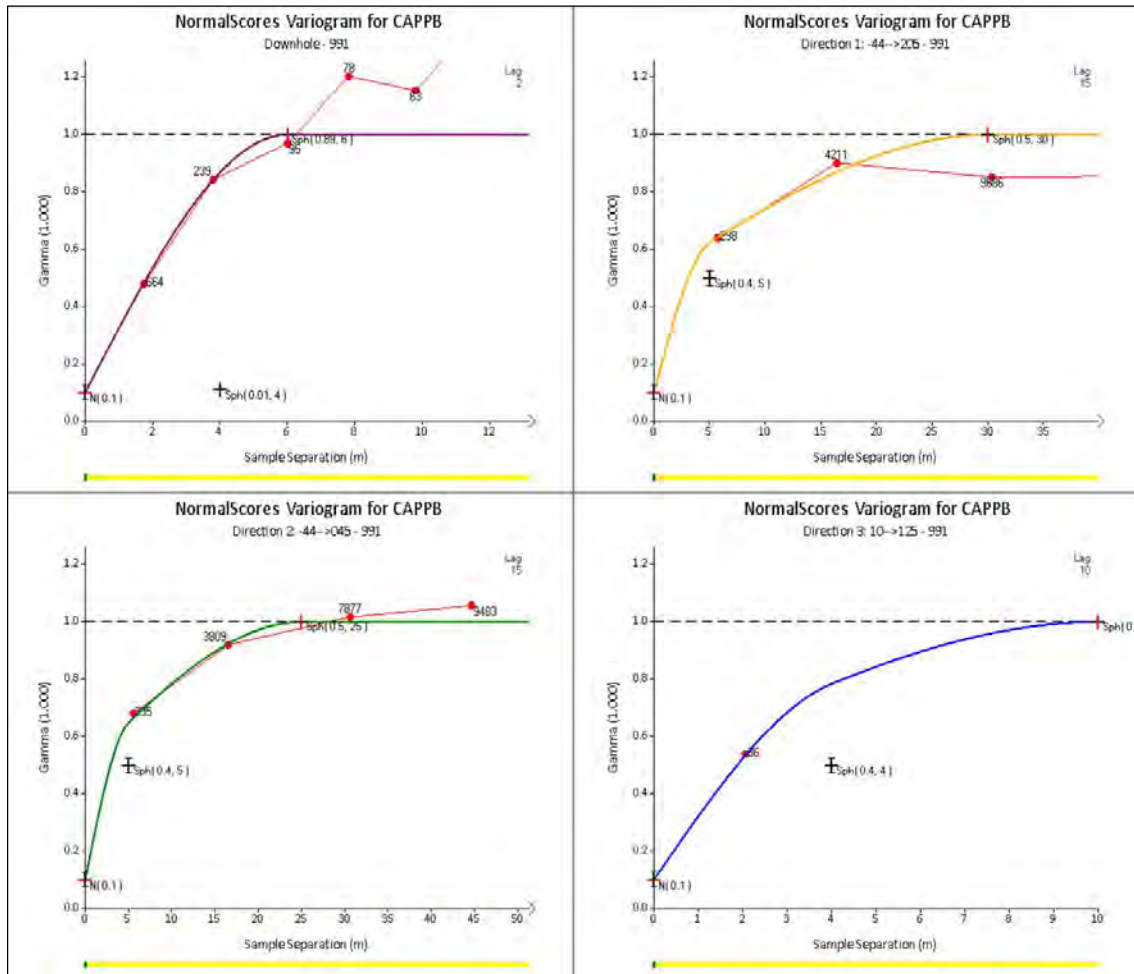

Figure 11-27 – Normal Score Variograms for Capped Lead, 99 Zone (Alexco, 2021b).

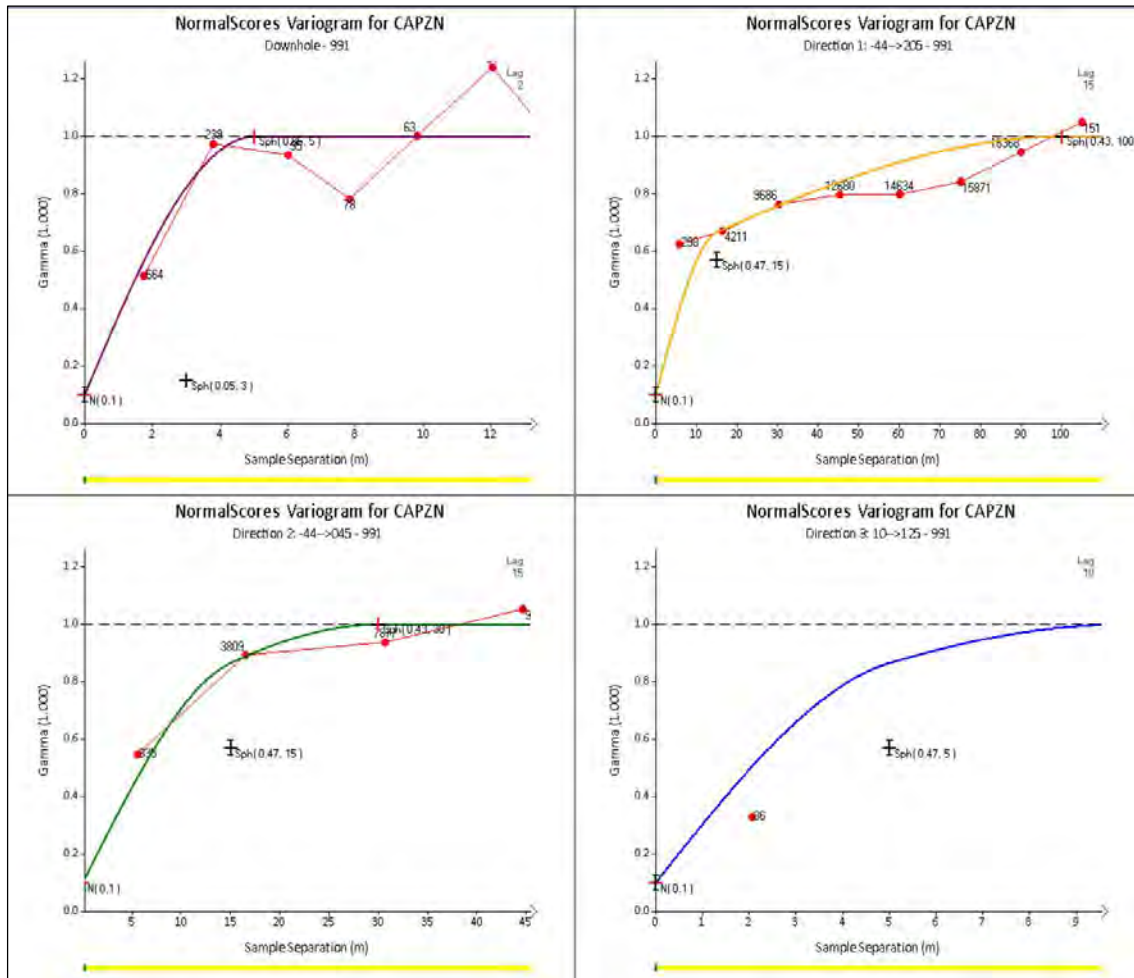

Figure 11-28 – Normal Score Variograms for Capped Zinc, 99 Zone (Alexco, 2021b).

11.2.6.1.3 The East Vein Variograms

In general, robust variograms could not be obtained for the East Vein due to limited data. Therefore, directional ranges were set at approximately 45 m to 60 m within the plane of the vein based on variogram parameters determined from the Southwest Zone.

11.2.6.2 Statistical Analysis and Variography for the Lucky Queen Deposit

Examination of the distribution of drill hole and chip assay sample populations suggests that drill hole assay data differ significantly from the chip assay data (Figure 11-29). The chip sample data were, therefore, used for continuity analysis, but were not used for Mineral Resource estimation.

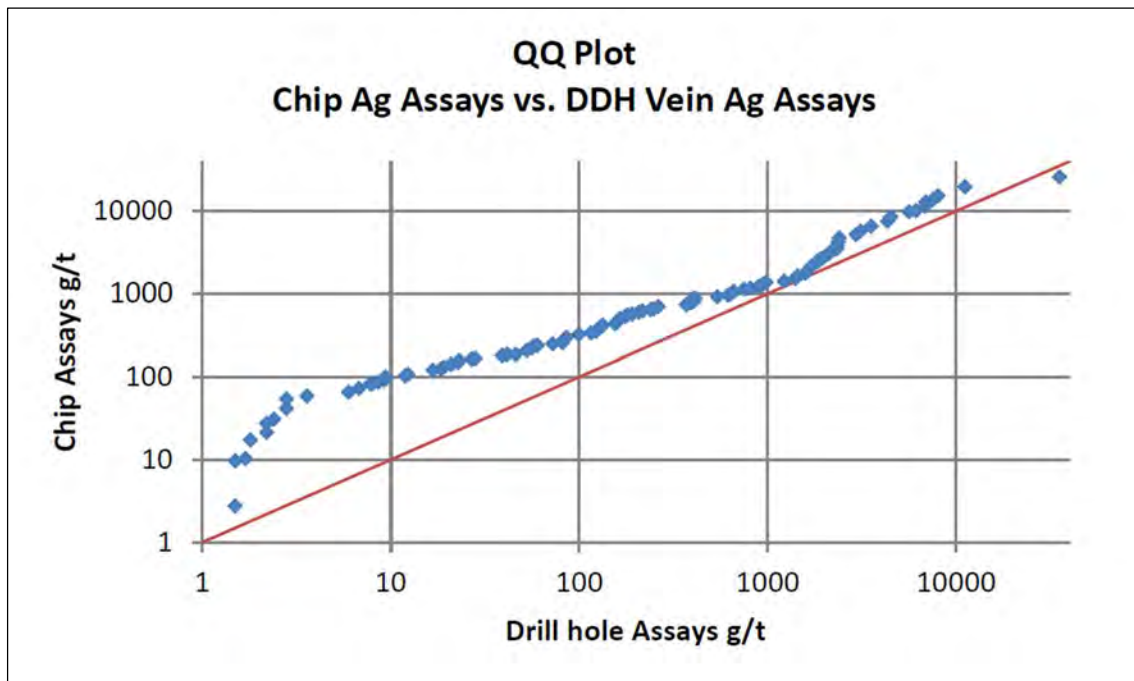

Figure 11-29 – Q-Q Plot of Chip and Drill Hole Silver Assay Sample Data (SRK, 2011a).

Summary statistics were compiled for the composite data, both for the defined Lucky Queen Vein and for a secondary splay identified by Alexco (Table 11-21). A total of 66 composites were derived for the Lucky Queen Vein, and 15 composites for the secondary splay. An additional five composites averaging 1,591 g/t Ag have been identified by Alexco but were not assigned to the primary Lucky Queen Vein or the secondary splay. Correlation analysis between elements indicates a positive correlation between silver and lead, with a correlation coefficient of 0.62.

Table 11-21 – Composite Data Summary Statistics for the Lucky Queen Deposit (Alexco, 2021b).

Type	Statistic	Ag (g/t)	Au (g/t)	Pb (ppm)	Zn (ppm)
Total Composites	Number of Samples	81	81	81	81
	Average	814	0.14	17,909	12,080
	Minimum	0.2	0.001	2,327	44
	Maximum	13,998	3	303,963	210,100
	Standard Deviation	1,929	0.38	42,651	31
	Coefficient of Variation	2.4	2.8	2.4	2.6
Vein Composites	Number of Samples	66	66	66	66
	Average	960	0.161	20,831	13,944
	Minimum	0.6	0.001	32	44
	Maximum	13,998	3	303,963	210,010
	Standard Deviation	2,098	0.412	46,265	34,315

Type	Statistic	Ag (g/t)	Au (g/t)	Pb (ppm)	Zn (ppm)
	Coefficient of Variation	2.2	2.6	2.20	2.50
Splay Composites	Number of Samples	15	1.5	15	15
	Average	174	0.022	5,054	3,877
	Minimum	0.2	0.001	23	116
	Maximum	2,125	0.155	60,714	27,195
	Standard Deviation	547	0.04	15,496	7,862
	Coefficient of Variation	3.20	1.80	3.1	2.0

Three-dimensional continuity analysis was conducted on the composite data and underground chip sample data for the Lucky Queen Vein. Downhole and directional un-transformed and normal-scores transformed and normalized experimental semi-variograms were examined for silver, with the horizontal and across-strike directions aligned with the modelled vein orientation (Table 11-22).

Rotation was defined by the GEMS ZYZ convention within the rotated block model coordinate space. Due to the spatial distribution of the data, only a strike experimental semi-variogram could be satisfactorily modelled, and the range of the resulting normal-scores experimental semi-variogram was used to define sample selection requirements and classification criteria.

Table 11-22 – Modelled Semi-Variogram for Silver (Alexco, 2021b).

Direction	Experimental Semi-Variogram	Range
Nugget	0.2	
Sill 1	0.2	12
Sill 2	0.6	100

11.2.6.3 Statistical Analysis and Variography for the Flame and Moth Deposit

After detailed statistical interrogation of the database indicating possible grade bias and due to potential overestimation when utilizing chip samples in the MRE, a conservative approach was adopted where all chip samples were excluded from the grade estimation pending further review.

Variograms were created using 1 m composites of the drilling data to determine search distance and directions for the vein domains in Christal and Lightning Zones. The high variability of the stringer mineralization made the construction of variograms for those domains difficult. For mineralized stringer zones, indicator shells were created at different threshold values, and the dimensions of these shells were used to influence search range and max value clamping range for the stringer estimators. Block grades for all metals were estimated using the ID² method. Table 11-23 shows the separate summary statistics for each element.

Table 11-23 – Flame and Moth Composite Summary Statistics (Hecla, 2023e).

Metal	Domain	Count	Length	Mean	SD	CV	Min	LQ	Median	UQ	Max
Ag (g/t)	Christal_SM	71	69.50	90.10	129.00	1.43	0.05	19.90	41.80	98.70	702.30
	Christal_VM	222	217.80	674.10	739.50	1.10	3.35	183.60	415.10	891.90	5,469.90
	Lightning_v0	71	63.30	538.70	862.60	1.60	3.11	121.00	321.20	665.60	6,804.20
	Lightning_v1	204	199.70	514.20	625.50	1.22	0.11	71.80	277.50	734.00	3,558.70
	Lightning_v2	84	72.70	595.00	786.20	1.32	1.20	93.50	284.00	905.80	4,556.50
	Lightning_SM	794	785.10	160.80	487.40	3.03	0.05	6.90	25.80	133.00	6,380.00
Au (g/t)	Christal_SM	71	69.50	0.09	0.16	1.75	0.00	0.01	0.03	0.10	0.87
	Christal_VM	222	217.80	0.58	0.59	1.01	0.00	0.18	0.38	0.80	3.61
	Lightning_v0	63	57.70	0.47	0.58	1.24	0.00	0.08	0.32	0.57	2.66
	Lightning_v1	181	177.00	0.38	0.44	1.15	0.00	0.09	0.25	0.52	2.53
	Lightning_v2	73	63.90	0.32	0.33	1.02	0.00	0.13	0.22	0.42	2.00
	Lightning_SM	653	644.90	0.08	0.26	3.09	0.00	0.00	0.02	0.07	4.20
Pb (ppm)	Christal_SM	71	69.50	2,081	2,460	1.18	7.00	671	1,392	2,209	12,777
	Christal_VM	222	217.80	29,450	57,907	1.97	61.60	3,851	9,212	25,705	463,882
	Lightning_v0	71	63.30	24,360	29,117	1.20	195.00	4,456	12,550	30,300	144,930
	Lightning_v1	204	199.70	14,198	24,117	1.70	34.00	1,950	6,228	16,673	174,542
	Lightning_v2	84	72.70	13,708	19,308	1.41	7.34	1,907	7,518	16,598	120,494
	Lightning_SM	794	785.10	5,928	14,680	2.48	0.05	178	1,008	6,740	247,700
Zn (ppm)	Christal_SM	71	69.50	12,929	13,896	1.08	25.00	3,373	9,154	16,623	67,450
	Christal_VM	222	217.80	42,549	37,123	0.87	168.00	12,550	35,569	60,576	192,915
	Lightning_v0	71	63.30	78,977	77,294	0.98	925.00	18,517	49,120	118,328	299,000
	Lightning_v1	804	199.70	67,019	61,838	0.92	31.00	11,590	53,694	109,600	281,000
	Lightning_v2	84	72.70	56,250	57,492	1.02	21.92	8,058	42,441	85,918	331,086
	Lightning_SM	794	785.10	18,342	27,879	1.52	17.00	904	5,630	27,015	286,112

During its review, Mining Plus noted that Hecla elected to exclude face sample data from the estimate due to potential bias in the population. Communication with site personnel did not fully define the nature of the bias however possible reasons included the use of a non-certified on-site laboratory for assay determination, or the physical properties of the higher-grade zones resulting in potential oversampling.

While Mining Plus accepts that face samples have been excluded from the MRE, it recommends that a review be conducted into the sampling and assaying processes and to outline the source of any potential bias. Face samples may provide reliable data at uniform boundaries and at set locations and regular patterns within the mining development. This population may provide important statistical information on close spaced sample behavior and determine local grade variability and continuity.

11.2.6.4 Statistical Analysis and Variography for the Onek Deposit

Examination of the distribution of the drill hole and chip assay sample populations suggests that the drill hole assay data differs significantly from the chip assay data. Therefore, the chip sample data were not used for Mineral Resource estimation.

Summary statistics were compiled for the composite data for the Onek veins (Table 11-24). A total of 351 composites were derived for Vein 1, 16 composites for Vein 1FW and 147 composites for Vein 2. Any composites lengths less than 0.5 m in length were linked to the previous composite to ensure equal weighting of all composites and to verify that all composites were between 0.5 m and 1.5 m in length. Correlation analysis between elements indicates a strong correlation between Ag and Pb, with a correlation coefficient of 0.83.

Table 11-24 – Composite Data Summary Statistics for Onek (Alexco, 2021b).

Type	Statistic	Ag (g/t)	Ag Cap (g/t)	Au (g/t)	Au Cap (g/t)	Pb (%)	Pb Cap (%)	Zn (%)	Zn Cap (%)
Total Composites	Number of Samples	514	514	514	514	514	514	514	514
	Average	181	175	0.51	0.49	1.4	1.26	9.5	8.93
	Minimum	0.64	0.64	0	0	0	0	0	0
	Maximum	3,410	3,000	7.68	4.89	46.13	27.94	50	35
	Standard Deviation	408	369	0.7	0.58	4.26	3.42	10.94	9.59
	Coefficient of Variation	2.25	2.11	1.37	1.18	3.04	2.71	1.15	1.07
Vein 1 Composites	Number of Samples	351	351	351	351	351	351	351	351
	Average	166	165	0.6	0.58	1.11	1.08	12.18	11.41
	Minimum	0	0	0	0	0	0	0	0
	Maximum	2,776	2,428	7.68	4.89	26.96	21.35	50	35
	Standard Deviation	309	299	0.77	0.63	2.92	2.75	11.92	10.36
	Coefficient of Variation	1.86	1.81	1.28	1.09	2.63	2.55	0.98	0.91
Vein 1FW Composites	Number of Samples	16	16	16	16	16	16	16	16
	Average	135	135	0.3	0.3	2.32	2.32	4.11	3.78
	Minimum	0.64	0	0	0	0	0	0	0
	Maximum	1,400	1,400	1.91	1.91	27.94	27.94	28.66	23.46
	Standard Deviation	364	364	0.59	0.59	7.15	7.15	7.29	6.14
	Coefficient of Variation	2.70	2.70	1.97	1.97	3.08	3.08	1.77	1.62
Vein 2 Composites	Number of Samples	147	147	147	147	147	147	147	147
	Average	222	201	0.31	0.3	1.99	1.57	3.7	3.56
	Minimum	0	0	0	0	0	0	0	0
	Maximum	3,410	3,000	1.77	1.65	46.13	25	30.14	24.1

Type	Statistic	Ag (g/t)	Ag Cap (g/t)	Au (g/t)	Au Cap (g/t)	Pb (%)	Pb Cap (%)	Zn (%)	Zn Cap (%)
	Standard Deviation	583	499	0.41	0.39	6.12	4.16	4.51	3.93
	Coefficient of Variation	2.63	2.48	1.32	1.30	3.08	2.65	1.22	1.10

Experimental correlograms and correlogram models were generated for silver, lead, zinc, and gold from combined composite grade data for Vein 1 and Vein 1FW and from composite grade data for Vein 2. The nugget effect was established from downhole correlograms. Directional and downhole correlograms were examined for silver, lead, zinc, and gold. Apart from zinc, modeled directions of spatial continuity were aligned with strike and dip directions of modeled vein orientations. For zinc, the major direction of continuity was modelled as a shallow dipping south-west trending structure. Nugget effect and across-structure continuity was established from downhole correlograms. Rotation was defined by the GEMS ZYZ convention within the rotated block model coordinate space. The continuity ellipsoids for silver, lead, zinc, and gold were displayed as search ellipsoids in GEMS to validate the ellipsoid orientations. The correlogram models used for grade estimation within Vein1 and Vein 1FW are shown in Figure 11-30 and Figure 11-31 and Vein 2 (Figure 11-32) and are summarized in Table 11-25.

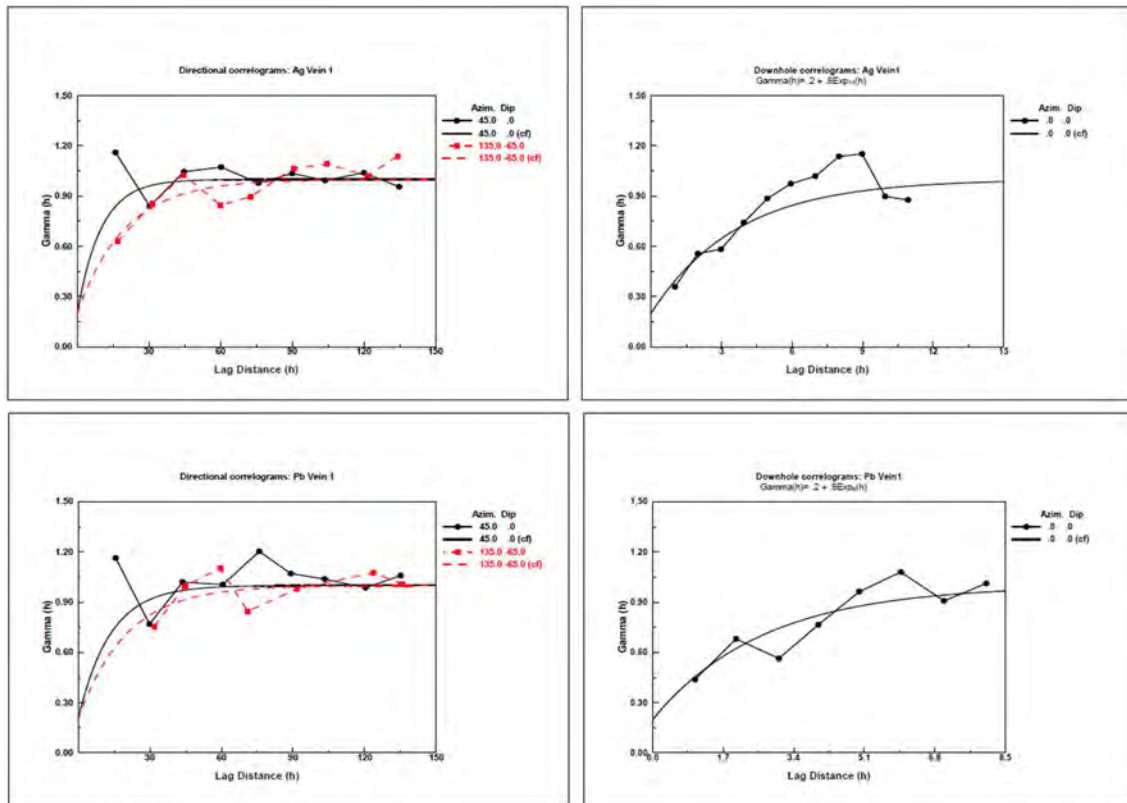

Figure 11-30 – Modelled Directional and Downhole Correlograms for Vein 1 and Vein 1 FW (RPA, 2017).

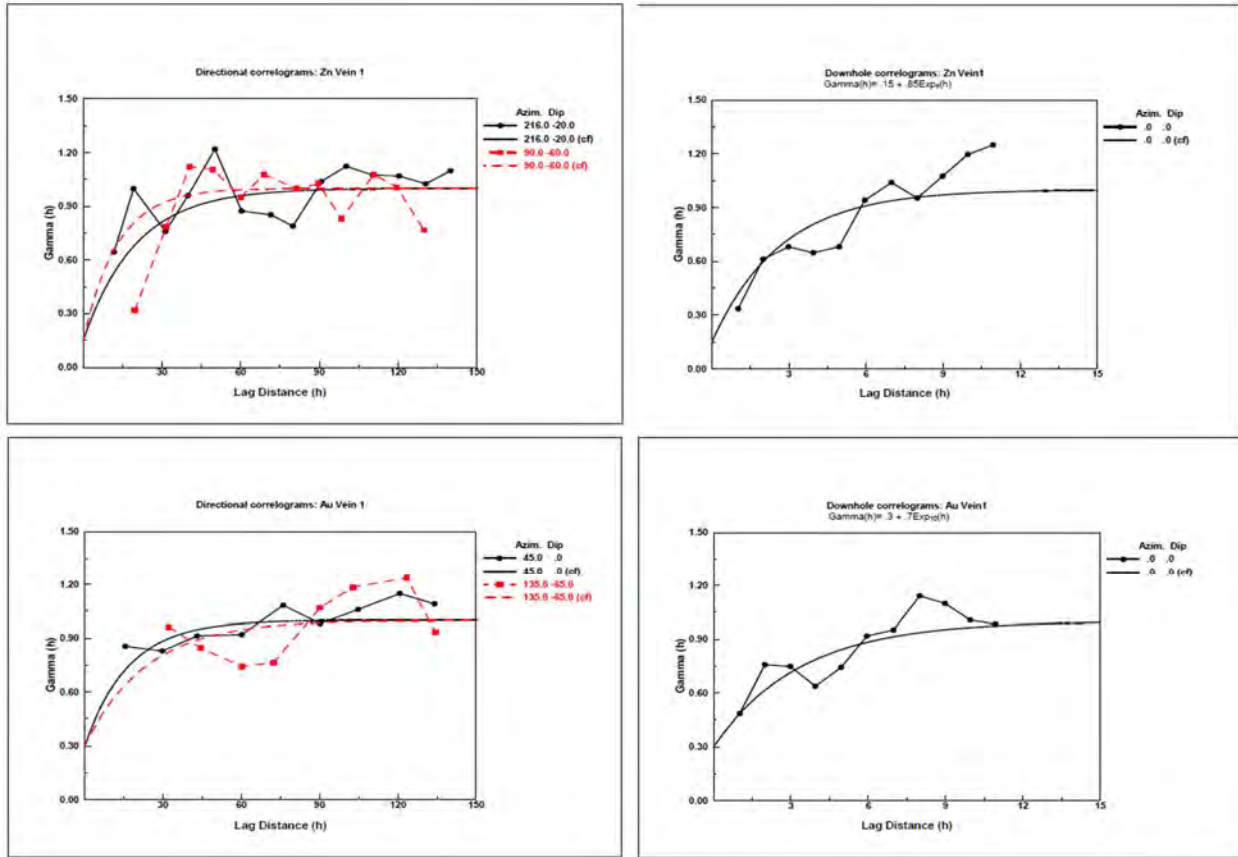

Figure 11-31 – Modelled Directional and Downhole Correlograms for Vein 1 and Vein 1 FW (RPA, 2017).

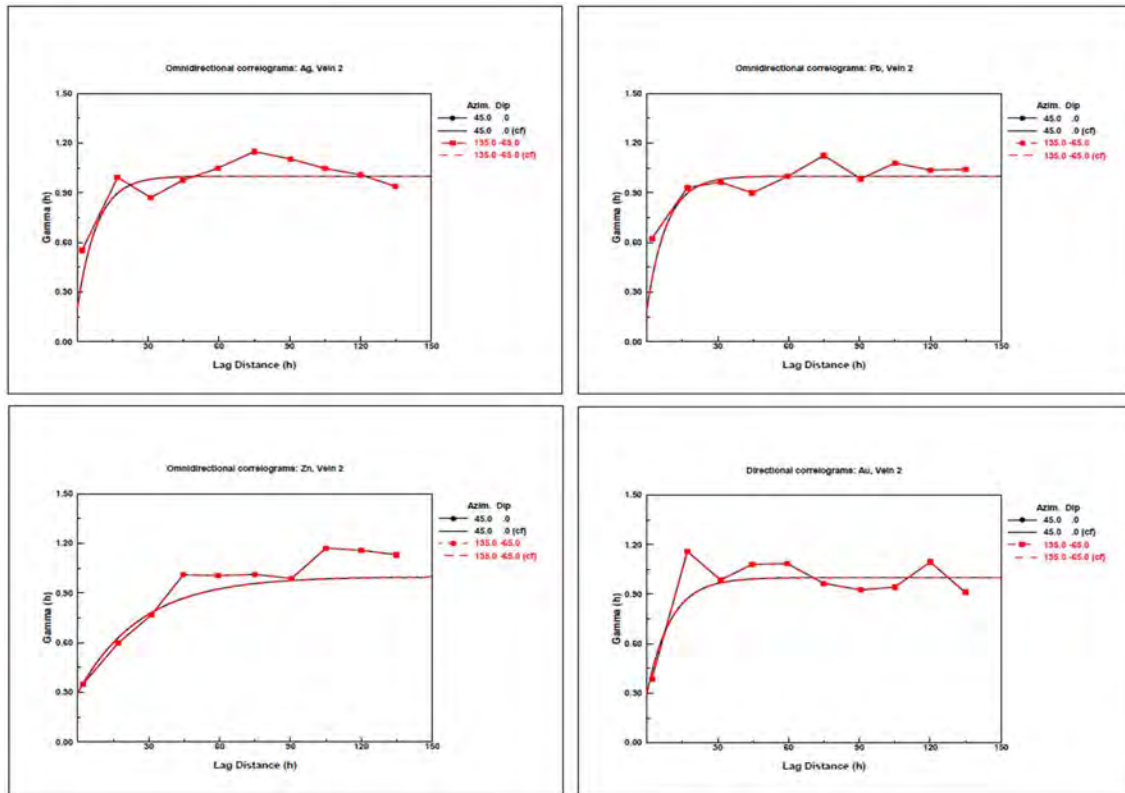

Figure 11-32 – Modelled Omnidirectional Correlograms for Vein 2 (RPA, 2017).

Table 11-25 – Modelled Correlograms for Onek Veins (Alexco, 2021b).

Metal	Zone	Nugget C ₀	Sill C	Gemcom Rotations (RRR rule)			Range a		
				Around Z	Around Y	Around Z	X-Rot	Y-Rot	Z-Rot
Silver	Vein 1 and Vein 1FW	0.20	0.80	-45.00	65	0	60	30	11
	Vein 2	0.20	0.80	-45	65	0	25	25	10
Lead	Vein 1 and Vein 1FW	0.20	0.80	-45	65	0	60	40	8
	Vein 2	0.20	0.80	-45	65	0	25	25	10
Zinc	Vein 1 and Vein 1FW	0.15	0.85	-45	65	-70	60	40	8
	Vein 2	0.30	0.70	-45	65	0	80	80	7
Gold	Vein 1 and Vein 1F	0.30	0.70	-45	65	0	70	50	10
	Vein 2	0.30	0.70	-45	65	0	30	30	10

11.2.6.5 Statistical Analysis and Variography for the Bermingham Deposit

Variograms were created using 1m composites of the drill data to determine search directions and initial search ranges for each domain. Variograms were created for the primary vein systems: Bear, Bermingham Main and Footwall for Ag, Au, Pb, Zn. Stringer mineralization zones utilized the values from the dominant vein mineralization associated with those domains, as sample counts were low. Variograms for the West Dipper system could not be generated due to limited data and search directions for West Dipper were based on the orientations of the domains. Table 11-26 to Table 11-29 below summarize the composite statistics for Arctic, Bear, Etta and North East Zones.

Table 11-26 – Bermingham Composite Summary Statistics for the Arctic Zone (Hecla, 2023f).

Zone	Domain	Metal	Count	Length	Mean	SD	CV	Min	LQ	Median	UQ	Max
Arctic	BM_VF	Ag	98	92.01	874	832	0.95	0.10	243	575	1,314	3,720
		Au	95	89.61	0.21	0.26	1.22	0.01	0.06	0.13	0.24	1.24
		Pb	98	92.01	20,255	23,142	1.14	3.93	3,221	12,802	27,960	109,500
		Zn	98	92.01	22,753	25,177	1.11	17.02	5,850	15,673	27,346	127,000
	FW_VF	Ag	62	58.91	1,392	1,342	0.96	8.13	457	957	1,994	5,190
		Au	62	58.91	0.22	0.17	0.78	0.05	0.10	0.18	0.29	0.73
		Pb	62	58.91	49,201	68,725	1.40	37.50	5,520	26,345	57,681	305,200
		Zn	62	58.91	20,901	27,715	1.33	117.92	1,738	9,140	24,820	120,500
	BR_VF	Ag	41	37.07	437	484	1.11	2.60	54	260	560	1,745
		Au	38	34.34	0.07	0.07	0.89	0.01	0.04	0.05	0.10	0.28
		Pb	41	37.07	12,719	19,252	1.51	42.00	1,152	5,175	13,357	91,314
		Zn	41	37.07	7,273	7,822	1.08	522.05	2,210	3,657	10,400	32,500

Table 11-27 – Bermingham Composite Summary Statistics for the Bear Zone (Hecla, 2023f).

Zone	Domain	Metal	Count	Length	Mean	SD	CV	Min	LQ	Median	UQ	Max
Bear	BM_VF	Ag	58	49.36	1,067	2,202	2.06	0	74	300	842	12,003
		Au	58	49.36	0.21	0.25	1.15	0.01	0.05	0.11	0.26	1.64
		Pb	58	49.36	13,204	15,477	1.17	9	1,846	3,270	23,661	60,404
		Zn	58	49.36	13,896	21,065	1.52	123	1,830	5,800	18,031	180,500
	BR_VF	Ag	137	123.48	1,931	3,049	1.58	2	82	573	2,318	11,857
		Au	134	122.2	224.00	0.32	1.42	0.01	0.03	0.11	0.20	1.35
		Pb	137	123.48	41,166	69,328	1.68	20	2,180	10,572	41,400	3,782
		Zn	137	123.48	17,179	24,123	1.40	26	1,448	7,347	22,464	134,121
	FW_VF	Ag	73	69.87	1,566	2,017	1.29	13	313	792	1,744	9,350
		Au	73	69.87	0.21	0.24	1.13	0.01	0.05	0.13	0.27	1.33
		Pb	73	69.87	35,535	43,624	1.23	218	4,410	16,750	44,684	180,626
		Zn	73	69.87	27,818	40,531	1.46	97	2,550	10,489	33,141	216,000

Zone	Domain	Metal	Count	Length	Mean	SD	CV	Min	LQ	Median	UQ	Max
	BR_S_VF	Ag	22	20.52	2,395	2,633	1.10	5	535	1,007	3,668	7,558
		Au	22	20.52	0.28	0.30	1.06	0.01	0.07	0.15	0.43	0.90
		Pb	22	20.52	8,909	103,279	1.16	153	10,673	16,322	154,060	286,915
		Zn	22	20.52	20,655	28,520	1.38	288	4,387	10,031	26,600	115,915
	WD2_VF	Ag	12	12.74	641	455	0.71	20	292	504	1,012	1,370
		Au	12	12.74	0.11	0.05	0.41	0.01	0.10	0.12	0.14	0.18
		Pb	12	12.74	34,356	24,720	0.72	581	2,237	28,644	44,415	103,000
		Zn	12	12.74	15,759	10,195	0.65	1,309	9,470	15,539	21,726	32,925
	WD_VF	Ag	27	24.66	1,057	990	0.94	1	169	1,070	1,701	4,850
		Au	27	24.66	0.11	0.09	0.81	0.01	0.03	0.09	0.16	0.37
		Pb	27	24.66	18,397	17,739	0.96	26	1,009	15,185	31,000	52,644
		Zn	27	24.66	17,734	25,449	1.44	92	4,250	7,793	19,513	107,980
	WDs_VF	Ag	8	7.8	3,451	2,943	0.85	454	799	3,523	4,891	9,386
		Au	8	7.8	0.39	0.30	0.77	0.05	0.06	0.38	0.72	0.84
		Pb	8	7.8	168,084	177,957	1.06	1,150	4,033	184,100	352,849	411,364
		Zn	8	7.8	60,700	56,681	0.93	4,721	13,250	36,467	120,778	127,317

Table 11-28 – Bermingham Composite Summary Statistics for the Etta Zone (Hecla, 2023f).

Zone	Domain	Metal	Count	Length	Mean	SD	CV	Min	LQ	Median	UQ	Max
Etta	BM_VF	Ag	36	36.58	877	967	1.10	86	149	573	1,272	4,583
		Au	36	36.58	0.10	0.10	0.95	0.01	0.05	0.07	0.13	0.53
		Pb	36	36.58	35,882	37,050	1.03	365	365	20,015	55,277	144,464
		Zn	36	36.58	28,358	24,209	0.85	2,826	2,826	16,000	39,052	89,808
	FW_VF	Ag	27	26.92	489	311	0.64	1.00	1.00	464	757	1,235
		Au	27	26.92	0.07	0.05	0.71	0.01	0.01	0.06	0.12	0.22
		Pb	27	26.92	15,342	16,288	1.06	55	55	7,932	23,867	71,400
		Zn	27	26.92	22,402	15,706	0.70	22	22	22,858	33,104	57,126

Table 11-29 – Bermingham Composite Summary Statistics for the North East Zone (Hecla, 2023f).

Zone	Domain	Metal	Count	Length	Mean	SD	CV	Min	LQ	Median	UQ	Max
North East	BM_VF	Ag	143	129.17	714	1,286	1.80	2.41	45	236	694	7,430
		Au	143	129.17	0.19	0.25	1.33	0.01	0.05	0.08	0.24	1.43
		Pb	143	129.17	21,119	34,217	1.62	18	1,338	5,938	24,498	222,100
		Zn	143	129.17	14,864	22,919	1.54	18	1,378	6,725	16,050	190,500
	FW_VF	Ag	230	221.33	1,500	2,215	1.48	0.05	168	678	1,770	12,868
		Au	230	221.33	0.25	0.31	1.27	0.01	0.05	0.14	0.32	1.69
		Pb	230	221.33	48,220	76,665	1.59	12	3,575	19,900	56,394	487,700
		Zn	230	221.33	18,270	31,075	1.70	9.00	677	4,120	19,613	169,820

Zone	Domain	Metal	Count	Length	Mean	SD	CV	Min	LQ	Median	UQ	Max
	BM2_VF	Ag	46	40.89	454	935	2.06	4.50	34	149	266	5,877
		Au	46	40.89	0.10	0.12	1.14	0.01	0.03	0.06	0.14	0.58
		Pb	46	40.89	12,313	20,384	1.66	75	1,725	5,140	12,780	108,000
		Zn	46	40.89	17,052	21,380	1.25	72	1,444	5,310	31,758	91,300
	BR_VF	Ag	38	36.36	935	1,256	1.34	4.50	83	380	1,329	5,010
		Au	38	36.36	0.13	0.13	1.02	0.01	0.03	0.10	0.17	0.51
		Pb	38	36.36	18,615	27,128	1.46	191	1,002	6,590	23,017	106,340
		Zn	38	36.36	19,073	19,955	1.05	140	2,599	9,910	34,633	66,315

11.2.7 BLOCK MODEL AND GRADE ESTIMATION

11.2.7.1 Block model and Grade Estimation for the Bellekeno Deposit

A rotated block model was constructed to cover the entire extent of the mineralized veins. The block model included separate sub models for silver, lead, and zinc grade estimates, as well as bulk density, classification criteria, validation estimates, and a calculated block value. A sub-block model was used to calculate volume and tonnage values based on the vein wireframes, classification criteria, and mined out shapes. The geometrical parameters of the block model are summarized in Table 11-30.

Table 11-30 – Block Model Location and Setup, MinePlan Convention (Alexco, 2021b).

Description	Easting (X)	Northing (Y)	Elevation (Z)
Block model origin (NAD 83 Zone 8N)	486,200	7,085,400	600
Block dimensions (meters)	5	3	5
Number of blocks	400	100	160
Rotation (degrees)	307.50° (clockwise)		

Grades were interpolated into blocks using an Ordinary Kriging estimation method. Search ellipses were set up to parallel the strike and dip of the veins. For silver, lead, and zinc, a two-pass series of expanding search ellipsoids were used for sample selection and estimation.

Weighted capped composite data used for the estimation was restricted to samples located in the respective veins. Additional zinc threshold search restrictions were applied to all three vein zones. Individual block grades were used to calculate an NSR block model. Estimation criteria for each vein zone are summarized in Table 11-31.

Table 11-31 – Search Ellipse Parameters for the Bellekeno Deposit (Alexco, 2021b).

Vein	Metal	Search Pass	MinePlan Rotations			Range			Number of Composites		Max. Sample per hole	High Grade Restriction	
			Principal Azimuth	Principal Dip	Intermed Azimuth	X-Rot	Y-Rot	Z-Rot	Min	Max		Grade	3D Search
SW	Ag	1	-164°	-33°	66°	45	30	10	4	6	2	-	-
		2				113	75	25	2	6	2	-	-
	Pb	1				40	25	10	4	6	2	-	-
		2				100	63	25	2	6	2	-	-
	Zn	1				60	40	10	4	6	2	10.0%	30m
		2				150	75	25	2	6	2	10.0%	30m
99	Ag	1	-155°	-44°	76°	30	25	10	4	6	2	-	-
		2				75	63	25	2	6	2	-	-
	Pb	1				30	25	10	4	6	2	-	-
		2				75	63	25	2	6	2	-	-
	Zn	1				100	30	10	4	6	2	10.5%	50m
		2				250	75	25	2	6	2	10.5%	50m
East	Ag	1	-172°	-46°	61°	45	30	10	4	6	2	-	-
		2				113	75	25	2	6	2	-	-
	Pb	1				45	25	10	4	6	2	-	-
		2				100	63	25	2	6	2	-	-
	Zn	1				60	40	10	4	6	2	10.5%	60m
		2				150	100	25	2	6	2	10.5%	60m

11.2.7.2 Block Model and Grade Estimation for the Lucky Queen Deposit

A rotated block model was constructed to cover the entire extent of the mineralized veins as defined by Alexco. The block model included separate sub models for silver, lead, zinc, and gold grade estimates, as well as estimated bulk density, classification criteria, validation estimates, and a calculated block value. A block percentage model was used to accurately determine volume and tonnage values based on the reviewed and validated vein wireframes supplied by Alexco. The geometrical parameters of the block model are summarized in Table 11-32.

Table 11-32 – Block model Location and Setup for the Lucky Queen Deposit (Alexco, 2021b).

Description	Easting (X)	Northing (Y)	Elevation (Z)
Block model origin (NAD 83 Zone 8N)	486,900	7,091,300	1,200
Block dimensions (meters)	10	10	10
Number of blocks	70	100	50
Rotation (degrees)	-50° (counter-clockwise)		

An ID² was used for the estimation of block grades. A two-pass series of expanding search ellipsoids with varying minimum sample requirements was used for sample selection and estimation, with the primary and secondary axes of the search ellipsoid defined by the silver semi-variogram range. Composite data used during estimation were restricted to samples located in their respective domain. Individual composite grades were then used to calculate a block model. For the second pass, estimation results were also iteratively queried to ensure that all potential Mineral Resources within the defined domains were estimated.

During the first pass, four to 12 composites from two or more drill holes within a search ellipsoid corresponding to 50% of the semi-variogram range were required for the estimation. All blocks estimated during the first pass were classified as Indicated (Table 11-33).

During the second pass, the search ellipse was expanded to ensure that all blocks within the defined vein and splay models were estimated. Between four to 12 composites from one or more drill holes were used for estimation. All blocks estimated during the second pass were classified as Inferred. All splay resources were also classified as Inferred due to the small number of total samples for this domain.

Table 11-33 – Search Ellipse Parameters for the Lucky Queen Deposit (Alexco, 2021b).

Estimator	Search Pass	Search Type	Rotation		Search Ellipse Size			Number of Composites		Max. Samples per hole
			Z	Y	X (m)	Y (m)	Z (m)	Min.	Max.	
ID ²	1	Ellipse	0°	50°	50	50	10	4	12	3
ID ²	2	Ellipse	0°	50°	300	300	60	4	12	0

11.2.7.3 Block Model and Grade Estimation for the Flame and Moth Deposit

A rotated block model was constructed to include the extent of the mineralized veins as defined by Hecla, and included estimations for silver, lead, gold, zinc and specific gravity. Block model dimensions and parameters are found below in Table 11-34. A series of calculations have been applied for the conversion of grams per tonne to ounce per ton or percent. This was done after the estimation with an additional set of calculations to determine the NSR value for each block.

Table 11-34 – Block Model location and Setup for the Flame and Moth Deposit (Hecla, 2023e).

Description	Easting (X)	Northing (Y)	Elevation (Z)
Block Model Origin	483,424	7,086,073	420
Parent Block Dimension (m)	3	5	5
Number of Blocks	101	215	110
Sub-Block Dimension	0.375	0.625	0.625

Description	Easting (X)	Northing (Y)	Elevation (Z)
AZ Rotation	30° clockwise		

The resource estimation methodology consisted of assays being composited to 1 m intervals with all composites <0.5 m being distributed equally among the other composites in the domain. Ag, Pb, Au and Zn were estimated using ID². Outlier composite grades were utilized with distance threshold clamping in the estimates where necessary to limit their influence. Where used, the distance for clamping was 25% of the total search range for pass 1. Specific gravity data (combination of core bulk density and adjusted pulp density values) was estimated by ID² and any unestimated blocks were assigned an average specific gravity of 3.52 for the mineralization zones, and 2.74 in the waste model outside the mineralized zones.

The selection parameters, search radii, and directions of search axes for Christal and Lightning was determined by variogram models, indicator shells, and visual inspection of the mineralized domain and associated data. Minimum and maximum samples, number of samples per drillhole, clamping values and distance thresholds were finalized by conducting many test resource estimates for each domain and reviewing global means and local estimates compared to composite grades.

In the Lightning and Christal Zones, the Ag, Au, Pb, Zn, and Cu metal grade estimation involved two passes. Pass two accounted for twice the search distance compared to the first pass. A percentage of the search pass distance was selected to restrict the search radius of the high-grade assays (Table 11-35 and Table 11-36).

Table 11-35 – Search Ellipse Parameters for the Lightning Zone in the Flame and Moth Deposit (Hecla, 2023e).

Domain	Metal	Search Pass	Ellipsoid Directions			Ellipsoid Ranges			No. of Samples			Outlier Restrictions		
			Dip	Dip Azi	Pitch	Major	Semi-Maj	Minor	Min	Max	Max per DH	Method	Distance %	Threshold
v0	Ag	1	64	112	49	120	60	20	3	3	3	Clamp	25	2,000
		2	64	112	49	240	120	20	1	3	3	Clamp	12.5	2,000
	Pb	1	64	112	49	120	60	20	3	3	3	-	-	-
		2	64	112	49	240	120	20	1	3	3	-	-	-
	Zn	1	64	112	49	120	60	10	3	3	3	-	-	-
		2	64	112	49	240	120	20	1	3	3	-	-	-
	Au	1	64	112	49	120	60	20	3	3	3	-	-	-
		2	64	112	49	240	120	20	1	3	3	-	-	-
v1	Ag	1	64	112	49	120	60	10	3	3	3	Clamp	25	2,000
		2	64	112	49	240	120	20	1	3	3	Clamp	12.5	2,000
	Pb	1	64	112	49	120	60	10	3	3	3	-	-	-
		2	64	112	49	240	120	20	1	3	3	-	-	-

Domain	Metal	Search Pass	Ellipsoid Directions			Ellipsoid Ranges			No. of Samples			Outlier Restrictions		
			Dip	Dip Azi	Pitch	Major	Semi-Maj	Minor	Min	Max	Max per DH	Method	Distance %	Threshold
	Zn	1	64	112	49	120	60	10	3	3	3	-	-	-
		2	64	112	49	240	120	20	1	3	3	-	-	-
	Au	1	64	112	49	120	60	10	3	3	3	-	-	-
		2	64	112	49	240	120	20	1	3	3	-	-	-
v2	Ag	1	64	112	49	120	60	10	3	3	3	-	-	-
		2	64	112	49	240	120	20	1	3	3	-	-	-
	Pb	1	64	112	49	120	60	10	3	3	3	-	-	-
		2	64	112	49	240	120	20	1	3	3	-	-	-
	Zn	1	64	112	49	120	60	30	3	3	3	-	-	-
		2	64	112	49	240	120	30	1	3	3	-	-	-
	Au	1	64	112	49	120	60	20	3	3	3	-	-	-
		2	64	112	49	240	120	20	1	3	3	-	-	-
sm	Ag	1	61	118	25	90	70	10	3	6	6	-	-	-
		2	61	118	25	180	140	20	1	6	6	-	-	-
	Pb	1	61	118	25	90	70	10	3	6	6	-	-	-
		2	61	118	25	135	105	15	1	6	6	-	-	-
	Zn	1	61	118	25	90	70	20	3	6	6	-	-	-
		2	61	118	25	180	140	20	1	6	6	-	-	-
	Au	1	61	118	25	90	70	10	3	3	3	-	-	-
		2	61	118	25	180	140	20	1	3	3	-	-	-

Table 11-36 – Search Parameters for the Christal Zone in the Flame and Moth Deposit (Hecla, 2023e).

Domain	Metal	Search Pass	Ellipsoid Directions			Ellipsoid Ranges			No. of Samples			Outlier Restrictions		
			Dip	Dip Azi	Pitch	Major	Semi-Maj	Minor	Min	Max	Max per DH	Method	Distance %	Threshold
vm	Ag	1	67	114	141	64	31	10	3	3	3	Clamp	25	2,750
		2	67	114	141	146	70	20	1	3	3	Clamp	13	2,750
	Pb	1	67	114	141	64	31	10	3	2	2	-	-	-
		2	67	114	141	146	70	20	1	2	2	-	-	-
	Zn	1	67	114	141	64	31	20	3	3	3	-	-	-
		2	67	114	141	130	62	20	1	3	3	-	-	-
	Au	1	67	115	10	62	45	20	3	3	3	-	-	-
		2	67	115	10	124	90	20	1	3	3	-	-	-
sm	Ag	1	67	114	141	64	31	5	3	3	3	-	-	-

Domain	Metal	Search Pass	Ellipsoid Directions			Ellipsoid Ranges			No. of Samples			Outlier Restrictions		
			Dip	Dip Azi	Pitch	Major	Semi-Maj	Minor	Min	Max	Max per DH	Method	Distance %	Threshold
		2	67	114	141	130	62	10	1	3	3	-	-	-
	Pb	1	67	114	141	64	31	20	1	3	3	-	-	-
		2	67	114	141	130	62	20	3	3	3	-	-	-
	Zn	1	67	114	141	64	31	20	3	3	3	-	-	-
		2	67	114	141	130	62	20	1	3	3	-	-	-
	Au	1	67	115	10	130	62	10	3	3	3	-	-	-
		2	67	115	10	64	31	5	1	3	3	-	-	-

Mining Plus noted that Hecla applied similar ranges and min/max sample numbers to many of the vein estimates while the Christal and Lightning Zones have discrete rotations and ranges. The 2015 estimate and investigation by Mining Plus indicated that the range was shorter than used for the current 2023 estimate. The implementation of a large search range means that estimates quickly reach the maximum number of samples. It was noted that the search pass was not recorded in the model fields and the ratio of estimates from pass 1 and pass 2 could not be confirmed.

Mining Plus recommends the use of 3 search passes during estimation where each pass is typically set at the range of half, one and twice the variogram range accompanied by a decreasing number of samples for each subsequent search pass. This process control supports the use of increased data in the well-drilled sections of the mineralization while stepping out to less informed areas.

11.2.7.4 Block Model and Grade Estimation for the Onek Deposit

A rotated block model was constructed to cover the entire extent of the mineralized veins as defined by Alexco. The block model includes separate sub-models for silver, lead, zinc, and gold grade estimates, as well as estimated specific gravity, classification criteria, validation estimates and a calculated block dollar value. A block percentage model was used to accurately determine volume and tonnage values based on the supplied Alexco vein wireframes and the percentage contained within the underground workings removed from the vein percentage to account for the mined-out volume. The geometrical parameters of the block model are summarized in Table 11-37.

Table 11-37 – Onek Block model Location and Setup (Alexco, 2021b).

Description	Easting (X)	Northing (Y)	Elevation (Z)
Block model origin (NAD 83 Zone 8N)	485,350	7,087,200	1,120
Block dimensions (meters)	3	5	5

Description	Easting (X)	Northing (Y)	Elevation (Z)
Number of blocks	80	150	80
Rotation (degrees)	50° (clockwise)		

Ordinary Kriging of capped composite values was used for the estimation of block grades. Because of the strong correlation between density and contained metal, all grades were weighted against density and a grade times density model was prepared for silver, lead, zinc, and gold. Interpolation was carried out in two passes with expanding search ellipsoids with the primary and secondary axes of the search ellipsoid defined by the correlogram ranges. For Vein 1 and Vein 1F a third pass was used for sample selection and estimation of silver. Correlogram and search parameters derived for Vein 1 were applied to Vein 1 FW with varying minimum and maximum number of samples required for estimation.

Composite data used for estimation was restricted to samples located in the respective veins. Individual block grades were used to calculate a dollar equivalent value for each block. Estimation criteria for Vein 1, Vein 1F, and Vein 2 are summarized in Table 11-39, and Table 11-40, respectively.

Table 11-38 – Search Ellipse Parameters for Onek Vein 1 (Alexco, 2021b).

Commodity	Estimator	Search Pass	Search Type	Rotation			Search Ellipse Size			Number of Composites		Max. Samples per hole
				X	Y	Z	X (m)	Y (m)	Z (m)	Min.	Max.	
Ag	OK	1	Ellipse	5°	65°	90°	60	30	11	5	10	3
	OK	2	Ellipse	5°	65°	90°	90	45	33	5	10	3
	OK	3	Ellipse	5°	65°	90°	30	30	33	1	10	-
Pb	OK	1	Ellipse	5°	65°	0°	60	40	8	4	10	3
	OK	2	Ellipse	5°	65°	0°	90	60	32	4	10	3
Zn	OK	1	Ellipse	5°	65°	0°	60	40	8	4	10	3
	OK	2	Ellipse	5°	65°	0°	90	60	32	4	10	3
Au	OK	1	Ellipse	5°	65°	0°	70	50	10	5	10	3
	OK	2	Ellipse	5°	65°	0°	105	75	30	5	10	3

Table 11-39 – Search Ellipse Parameters for Onek Vein 1F (Alexco, 2021b).

Commodity	Estimator	Search Pass	Search Type	Rotation			Search Ellipse Size			Number of Composites		Max. Samples per hole
				X	Y	Z	X (m)	Y (m)	Z (m)	Min.	Max.	
Ag	OK	1	Ellipse	5°	65°	90°	60	30	11	3	10	2
	OK	2	Ellipse	5°	65°	90°	90	45	33	3	10	2
	OK	3	Ellipse	5°	65°	90°	30	30	33	1	10	-
Pb	OK	1	Ellipse	5°	65°	0°	60	40	8	3	10	2
	OK	2	Ellipse	5°	65°	0°	90	60	32	3	10	2

Commodity	Estimator	Search Pass	Search Type	Rotation			Search Ellipse Size			Number of Composites		Max. Samples per hole
				X	Y	Z	X (m)	Y (m)	Z (m)	Min.	Max.	
Zn	OK	1	Ellipse	5°	65°	0°	60	40	8	3	10	2
	OK	2	Ellipse	5°	65°	0°	90	60	32	3	10	2
Au	OK	1	Ellipse	5°	65°	0°	70	50	10	3	10	2
	OK	2	Ellipse	5°	65°	0°	105	75	30	3	10	2

Table 11-40 – Search Ellipse Parameters for Onek Vein 2 (Alexco, 2021b).

Commodity	Estimator	Search Pass	Search Type	Rotation			Search Ellipse Size			Number of Composites		Max. Samples per hole
				X	Y	Z	X (m)	Y (m)	Z (m)	Min.	Max.	
Ag	OK	1	Ellipse	5°	65°	0°	25	25	10	4	10	3
	OK	2	Ellipse	5°	65°	0°	75	75	30	4	10	3
Pb	OK	1	Ellipse	5°	65°	0°	25	25	10	4	10	2
	OK	2	Ellipse	5°	65°	0°	75	75	30	4	10	2
Zn	OK	1	Ellipse	5°	65°	0°	80	80	7	4	10	2
	OK	2	Ellipse	5°	65°	0°	120	120	21	4	10	2
Au	OK	1	Ellipse	5°	65°	0°	30	30	10	4	10	2
	OK	2	Ellipse	5°	65°	0°	75	75	30	4	10	2

11.2.7.5 Block Model and Grade Estimation for the Bermingham Deposit

The block model covers the entire extent of the mineralized domains and includes estimations for Ag, Au, Pb, Zn and SG. Based on the variability of the data, a parent block size of 2.5 m x 5 m x 5 m was tested to increase the resolution within the block model, provide more accurate local estimates, and to support the variety of mining methods that could be employed at Bermingham (Table 11-41).

Table 11-41 – Bermingham Block Model Location and Setup (Hecla, 2023f).

Description	Easting (X)	Northing (Y)	Elevation (Z)
Block model origin (NAD 83 Zone 8N)	479,402	7,087,573	1,442
Block dimensions (metres)	2.5	5	5
Number of blocks	487	130	155
Sub-block Dimensions	0.3125	0.3125	0.3125
Rotation (degrees)	135°		

Resource estimation methodology consisted of:

- Raw samples were capped before compositing where necessary.

- Assays composited to 1m intervals.
- All composites shorter than 0.5m were added to the previous interval within each wireframe.
- Ag, Au, Pb, Zn, and SG were estimated using ID².
- Clamping occurred on some veins in the North East Zone (Table 11-46).

The selection parameters, search radii, and directions of search axes were determined by variogram analysis and visual inspection of each domain and their associated data. Minimum and maximum samples, maximum samples per drillhole and clamping values were finalized by conducting many test resource estimates and reviewing global means and visually inspecting local estimates compared to composite grades. Estimation parameters are summarized in Table 11-42 to Table 11-45.

Table 11-42 – Search Ellipse Parameters for the Bermingham Arctic Zone (Hecla, 2023f).

Zone	Domain	Search Pass	Metal	Search Ellipse Size			Rotation			Number of Composites		Max. Samples per Hole
				X (m)	Y (m)	Z (m)	Dip	Dip Azi	Pitch	Min.	Max.	
Arctic	BM_sm_1	1	Ag	120	90	10	55	138	54	3	16	3
		2		160	120	20	55	138	54	1	16	3
		1	Au	90	66	10	55	130	113	3	16	3
		2		120	88	20	55	130	113	1	16	3
		1	Pb	97	69	10	55	130	54	3	16	3
		2		125	88	20	55	130	54	1	16	3
		1	Zn	120	97	10	55	130	56	3	16	3
		2		160	125	20	55	130	56	1	16	3
	BM_VF	1	Ag	120	90	10	55.2	138	54	3	16	3
		2		160	120	20	55.2	138	54	1	16	3
		1	Au	90	66	10	55	130	112	3	16	3
		2		120	88	20	55	130	112	1	16	3
		1	Pb	97	69	10	55	130	54	3	16	3
		2		125	88	20	55	130	54	1	16	3
		1	Zn	120	97	10	55	130	56	3	16	3
		2		160	125	20	55	130	56	1	16	3
	BR_sm_1	1	Ag	75	45	10	69.4	129	68	3	16	3
		2		100	60	20	69.4	129	68	1	16	3
		1	Au	96	75	10	70	129	23	3	16	3
		2		128	100	20	70	129	23	1	16	3
		1	Pb	150	105	10	70.3	129	105	3	16	3
		2		200	140	20	70.3	129	105	1	16	3
		1	Zn	95	90	10	70.3	129	112	3	16	3
		2		130	120	20	70.3	129	112	1	16	3
	BR_VF	1	Ag	75	45	10	69.4	129	68	3	16	3

Zone	Domain	Search Pass	Metal	Search Ellipse Size			Rotation			Number of Composites		Max. Samples per Hole
				X (m)	Y (m)	Z (m)	Dip	Dip Azi	Pitch	Min.	Max.	
	FW_sm_1	2	Au	100	60	20	69.4	129	68	1	16	3
		1		96	75	10	70.3	129	23	3	16	3
		2	Pb	128	100	20	70.3	129	23	1	16	3
		1		150	105	10	70.3	129	105	3	16	3
		2	Zn	200	140	20	70.3	129	105	1	16	3
		1		95	90	10	70.3	129	112	3	16	3
		2	Ag	130	120	20	70.3	129	112	1	16	3
		1		60	60	10	77.5	132	66	3	16	3
		2	Au	80	80	20	77.5	132	66	1	16	3
		1		75	60	10	77	139	58	3	16	3
		2	Pb	100	80	20	77	139	58	1	16	3
		1		90	77.5	10	0	0	90	3	16	3
		2	Zn	120	100	20	0	0	90	1	16	3
		1		96	72	10	77	132	111	3	16	3
	2	Ag	128	96	20	77	132	111	1	16	3	
	1		60	60	10	77.5	132	66	3	16	3	
	2	Au	80	80	20	77.5	132	66	1	16	3	
	1		75	60	10	77	140	58	3	16	3	
	2	Pb	100	80	20	77	140	58	1	16	3	
	1		90	77.5	10	77	132	52	3	16	3	
	2	Zn	120	100	20	77	132	52	1	16	3	
	1		96	72	10	77	132	111	3	16	3	
	2	Ag	128	96	20	77	132	111	1	16	3	

Table 11-43 – Search Ellipse Parameters for the Bermingham Bear Zone (Hecla, 2023f).

Zone	Domain	Search Pass	Metal	Search Ellipse Size			Rotation			Number of Composites		Max. Samples per Hole
				X (m)	Y (m)	Z (m)	Dip	Dip Azi	Pitch	Min.	Max.	
Bear	BM_sm_1	1	Ag	45.75	22.5	5	55.5	118	134	3	16	3
		2		61	30	7.5	55.5	118	134	1	16	3
		1	Au	52.5	39	5	55.5	118	74	3	16	3
		2		70	52	7.5	55.5	118	75	3	16	3
		1	Pb	70	52	7.5	55.5	118	76	1	16	3
		2		52.5	39	5	55.5	118	77	3	16	3
		1	Zn	52.5	39	5	55.5	118	78	3	16	3
		2		70	52	7.5	55.5	118	79	3	16	3
	1	Ag	90	45	10	55.5	118	135	3	16	3	
	2		122	60	20	55.5	119	135	1	16	3	

Zone	Domain	Search Pass	Metal	Search Ellipse Size			Rotation			Number of Composites		Max. Samples per Hole
				X (m)	Y (m)	Z (m)	Dip	Dip Azi	Pitch	Min.	Max.	
		1	Au	70	52	10	55.5	118	74	3	16	3
		2		105	78	20	55.5	118	74	1	16	3
		1	Pb	120	60	10	55.5	118	112	3	16	3
		2		160	82	20	55.5	118	112	1	16	3
		1	Zn	76	71	10	55.5	118	68	3	16	3
		2		106	92	20	55.5	118	68	1	16	3
	BR_HW_SM	Ag	1	54	32	10	78.7	111	170	3	16	3
			2	81	48	30	78.7	111	170	1	16	3
		Au	1	54	32	10	78.7	111	170	3	16	3
			2	81	48	30	78.7	111	170	1	16	3
		Pb	1	54	32	10	78.7	111	170	3	16	3
			2	81	48	30	78.7	111	170	1	16	3
		Zn	1	54	32	10	78.7	111	170	3	16	3
			2	81	48	30	78.7	111	170	1	16	3
	BR_S_VF	Ag	1	20	18	10	61.7	124	122	3	15	2
			2	50	36	15	61.7	124	122	3	10	2
			3	75	54	15	61.7	124	122	1	6	2
		Au	1	25	18	10	61.7	124	122	3	15	2
			2	50	36	15	61.7	124	122	3	10	2
			3	75	54	15	61.7	124	122	1	6	2
		Pb	1	25	18	10	61.7	124	122	3	16	2
			2	50	36	15	61.7	124	122	1	16	2
			3	75	54	15	61.7	124	122	1	6	2
		Zn	1	25	18	10	61.7	124	122	3	15	2
			2	50	36	15	61.7	124	122	3	10	2
			3	75	54	15	61.7	124	122	1	6	2
	BR_sm_1	Ag	1	51.38	44.25	5	62.6	126	92	3	16	3
			2	58.2	59	7.5	62.6	126	92	1	16	3
		Au	1	52.5	39.9	5	62.6	126	92	3	16	3
			2	69.6	53.2	7.5	62.6	126	92	3	16	3
Pb		1	69.6	53.2	7.5	62.6	126	92	1	16	3	
		2	52.2	39.9	5	62.6	126	92	3	16	3	
Zn		1	52.2	39.9	5	62.6	126	92	3	16	3	
		2	69.6	53.2	7.5	62.6	126	92	1	16	3	
BR_VF	Ag	1	105	90	10				3	16	3	
		2	140	120	20				1	16	3	
	Au	1	105	78	10	62.6	126	92	3	16	3	
		2	140	106	20	62.6	126	92	1	16	3	

Zone	Domain	Search Pass	Metal	Search Ellipse Size			Rotation			Number of Composites		Max. Samples per Hole	
				X (m)	Y (m)	Z (m)	Dip	Dip Azi	Pitch	Min.	Max.		
		1	Pb	80	66	10				3	16	3	
		2		160	132	20				1	16	3	
		1	Zn	105	102	10				3	16	2	
		2		140	136	20				1	16	2	
		FW_sm_1	1	Ag	58	56	10	72.6	140	154	3	16	3
			2		87	82	20	72.6	140	154	1	16	3
	1		Au	72	45	10	73	140	67	3	16	3	
	2			96	60	20	73	140	67	2	16	3	
	1		Pb	72	64	10	73	140	126	3	16	3	
	1		Zn	92	67.5	10	73	140	18	3	16	2	
	FW_VF	1	Ag	87	84	10	62	140	154	3	16	3	
		2		116	112	20	62	140	154	1	16	1	
		1	Au	72	45	10	62	140	67	3	16	3	
		2		96	60	20	62	140	67	1	16	3	
		1	Pb	72	64	10	62	140	126	3	16	3	
		2		72	64	10	62	140	126	1	16	3	
		1	Zn	91	72	10	62	140	18	3	16	3	
		2		122	90	20	62	140	18	1	16	3	
	WD_sm	1	Ag	25	18	10	55.3	270	165	3	16	3	
		2		50	36	15	55.3	271	165	1	16	3	
		3		75	54	15	55.3	272	165	1	6	2	
		1	Au	25	18	10	55.3	273	165	3	15	2	
		2		50	36	15	55.3	274	165	3	10	2	
		3		75	54	15	55.3	274	165	1	6	2	
		1	Pb	25	18	10	55.3	274	165	3	15	2	
		2		50	36	15	55.3	274	165	3	10	2	
		3		75	54	15	55.3	274	165	1	6	2	
		1	Zn	25	18	10	55.3	274	165	3	15	2	
		2		50	36	15	55.3	274	165	3	10	2	
		3		75	54	15	55.3	274	165	1	6	2	
WD_VF	1	Ag	25	18	10	55.3	274	165	3	15	2		
	2		50	36	15	55.3	274	165	3	10	2		
	3		75	54	15	55.3	274	165	1	6	2		
	1	Au	25	18	10	55.3	274	165	3	15	2		
	2		50	36	15	55.3	274	165	3	10	2		
	3		75	54	15	55.3	274	165	1	6	2		
	1	Pb	25	18	10	55.3	274	165	3	15	2		
	2		50	36	15	55.3	274	165	3	10	2		

Zone	Domain	Search Pass	Metal	Search Ellipse Size			Rotation			Number of Composites		Max. Samples per Hole
				X (m)	Y (m)	Z (m)	Dip	Dip Azi	Pitch	Min.	Max.	
		3	Zn	75	54	15	55.3	274	165	1	6	2
		1		25	18	10	55.3	274	165	3	15	2
		2		50	36	15	55.3	274	165	3	10	2
		3		75	54	15	55.3	274	165	1	6	2
	WD2_sm	Ag	1	25	18	10	37.7	306	3	3	15	2
			2	50	36	15	37.7	306	3	3	10	2
			3	75	54	15	37.7	306	3	1	6	2
		Au	1	25	15	10	37.7	306	3	3	15	2
			2	50	36	15	37.7	306	3	3	10	2
			3	75	54	15	37.7	306	3	1	6	2
		Pb	1	25	18	10	37.7	306	3	3	15	2
			2	50	36	15	37.7	306	3	3	10	2
			3	75	54	15	37.7	306	3	1	6	2
		Zn	1	25	18	10	37.7	306	3	3	15	2
			2	50	36	15	37.7	306	3	3	10	2
			3	75	54	15	37.7	306	3	1	6	2
	WD2_VF	Ag	1	25	18	10	37.7	306	3	3	15	2
			2	50	36	15	37.7	306	3	3	10	2
			3	75	54	15	37.7	306	3	1	6	2
		Au	1	25	18	10	37.7	306	3	3	15	2
			2	50	36	115	37.7	306	3	3	10	2
			3	75	54	15	37.7	306	3	1	6	2
		Pb	1	25	18	10	37.7	306	3	3	15	2
			2	50	36	15	37.7	306	3	3	10	2
			3	75	54	15	37.7	306	3	1	6	2
		Zn	1	25	18	10	37.7	306	3	3	15	2
			2	50	36	15	37.7	306	3	3	10	2
			3	75	54	15	37.7	306	3	1	6	2
	WDs_VF	Ag	1	25	18	10	55.3	270	165	3	15	2
			2	50	36	15	55.3	270	165	3	10	2
			3	75	54	15	55.3	270	165	1	6	2
		Au	1	25	18	10	55.3	270	165	3	15	2
			2	50	36	15	55.3	270	165	3	10	2
			3	75	54	15	55.3	270	165	1	6	2
		Pb	1	25	18	10	55.3	270	165	3	15	2
			2	50	36	15	55.3	270	165	3	10	2
3			75	54	15	55.3	270	165	1	6	2	
Zn		1	25	18	10	55.3	270	165	3	15	2	

Zone	Domain	Search Pass	Metal	Search Ellipse Size			Rotation			Number of Composites		Max. Samples per Hole
				X (m)	Y (m)	Z (m)	Dip	Dip Azi	Pitch	Min.	Max.	
		2		50	36	15	55.3	270	165	3	10	2
		3		75	54	15	55.3	270	165	1	6	2

Table 11-44 – Search Ellipse Parameters for the Bermingham North East Zone (Hecla, 2023f).

Zone	Domain	Search Pass	Metal	Search Ellipse Size			Rotation			Number of Composites		Max Samples per Hole
				X (m)	Y (m)	Z (m)	Dip	Dip Azi	Pitch	Min	Max	
North East	BM_sm_1	1	Ag	110	60	10	45.6	125	44	3	16	3
		2		150	80	20	45.6	125	44	1	16	3
		1	Au	120	60	10	45.6	125	17	3	16	3
		2		160	80	20	45.6	125	17	1	16	3
		1	Pb	105	66	10	46.4	125	18	3	16	3
		2		140	88	20	46.4	125	18	1	16	3
		1	Zn	105	90	10	0	0	90	3	16	3
		2		140	120	20	0	0	90	1	16	3
	BM_VF	1	Ag	110	60	10	45.6	125	44	3	16	3
		2		150	80	20	45.6	125	44	1	16	3
		1	Au	120	60	10	45.6	125	17	3	16	3
		2		160	80	20	45.6	125	17	1	16	3
		1	Pb	105	66	10	46.4	125	18	3	16	3
		2		140	88	20	46.4	125	18	1	16	3
		1	Zn	105	90	10	46.4	125	90	3	16	3
		2		140	120	20	46.4	125	90	1	16	3
	BM2_VF	1	Ag	110	60	10	44.5	135	90	3	16	3
		2		150	80	20	44.5	135	90	1	10	2
		1	Au	120	60	10	44.5	135	90	3	16	3
		2		160	80	20	44.5	135	90	1	10	2
		1	Pb	105	67	10	44.5	135	90	3	16	3
		2		130	90	20	44.5	135	90	1	10	2
		3		75	54	10	44.5	135	90	3	6	2
		1	Zn	105	90	10	44.5	135	90	1	16	3
		2		140	120	20	44.5	135	90	3	10	2
		BR_VF	1	Ag	69	42	10	74.9	117	139	3	16
	2		103.5		63	15	74.9	117	139	1	17	3
	1		Au	69	42	10	74.9	117	139	3	18	3

Zone	Domain	Search Pass	Metal	Search Ellipse Size			Rotation			Number of Composites		Max Samples per Hole	
				X (m)	Y (m)	Z (m)	Dip	Dip Azi	Pitch	Min	Max		
		2		103.5	63	15	74.9	117	139	1	19	3	
		1	Pb	69	42	10	74.9	117	139	3	20	3	
		2		103.5	63	15	74.9	117	139	1	21	3	
		1	Zn	69	42	10	74.9	117	139	3	22	3	
		2		103.5	63	15	74.9	117	139	1	23	3	
		FW_sm_1	1	Ag	75	45	10	75	131	104	3	24	3
			2		100	60	20	75	131	104	1	25	3
			1	Au	78	75	10	77	128	14	3	26	3
			2		110	100	20	77	128	14	1	27	3
			1	Pb	120	75	10	77	128	18	3	28	3
	2		160		100	20	77	128	18	3	29	3	
	1		Zn	105	45	10	0	0	90	3	30	3	
	2			105	60	20	0	0	90	1	31	3	
	FW_VF	1	Ag	75	45	10	74.6	131	104	3	32	3	
		2		100	60	20	74.6	131	104	1	33	3	
		1	Au	78	75	10	77	128	14	3	34	3	
		2		110	100	20	77	128	14	1	35	3	
		1	Pb	120	75	10	77	128	18	3	36	3	
		2		160	100	20	77	128	18	1	37	3	
		1	Zn	105	45	10	77	128	19	3	38	3	
		2		140	60	20	77	128	19	1	39	3	

Table 11-45 – Search Ellipse Parameters for the Bermingham Etta Zone (Hecla, 2023f).

Zone	Domain	Search Pass	Metal	Search Ellipse Size			Rotation			Number of Composites		Max. Samples per Hole
				X (m)	Y (m)	Z (m)	Dip	Dip Azi	Pitch	Min.	Max.	
Etta	BM_sm_1	1	Ag	100	50	10	63.6	122	126	3	16	3
		2		150	75	15	63.6	122	126	1	16	3
		1	Au	104	52	10	63.6	122	126	3	16	3
		2		150	75	15	63.6	122	126	1	16	3
		1	Pb	104	52	10	63.6	122	126	3	16	3
		2		150	75	15	63.6	122	126	1	16	3
		1	Zn	100	50	10	63.6	122	126	3	16	3
		2		150	75	15	63.6	122	126	1	16	3
	BM_VF	1	Ag	104	52	10	63.6	122	126	3	16	3
		2		150	75	15	63.6	122	126	1	8	3

Zone	Domain	Search Pass	Metal	Search Ellipse Size			Rotation			Number of Composites		Max. Samples per Hole
				X (m)	Y (m)	Z (m)	Dip	Dip Azi	Pitch	Min.	Max.	
		1	Au	104	52	10	63.6	122	126	3	16	3
		2		150	75	15	63.6	122	126	1	16	3
		1	Pb	104	52	10	63.6	122	126	3	16	3
		2		150	75	15	63.6	122	126	1	16	3
		1	Zn	104	52	10	63.6	122	126	3	16	3
		2		150	75	15	63.6	122	126	1	8	3
	FW_sm_1	1	Ag	110	61	10	74.8	133	124	3	16	3
				2	165	94.5	15	74.8	133	124	1	17
		1	Au	110	61	10	74.8	133	124	3	18	3
				2	165	91.5	15	74.8	133	124	1	19
		1	Pb	110	61	10	74.8	133	124	3	20	3
				2	165	91.5	15	74.8	133	124	1	21
		1	Zn	110	61	10	74.8	133	124	3	22	3
				2	165	94.5	15	74.8	133	124	1	23
	FW_VF	1	Ag	110	61	10	74.8	133	124	3	24	3
				2	165	91.5	15	74.8	133	124	1	25
		1	Au	110	61	10	74.8	133	124	3	26	3
				2	165	91.5	15	74.8	133	124	1	27
		1	Pb	110	61	10	74.8	133	124	3	28	3
				2	165	91.5	15	74.8	133	124	1	29
		1	Zn	110	61	10	74.8	133	124	3	30	3
				2	165	91.5	15	74.8	133	124	1	31

Table 11-46 - Outlier Restriction Method Applied at Bermingham North East Zone (Hecla, 2023f).

Zone	Domain	Search Pass	Metal	Search Ellipse Size			Rotation			Outlier Restriction		
				X (m)	Y (m)	Z (m)	Dip	Dip Azi	Pitch	Method	Distance	Threshold
North East	BM_VF	Zn	1	105	90	10	46.4	125	90	Discard	25	71800
			2	140	120	20	46.4	125	90	Discard	12.5	71800

Mining Plus noted that the 2015 version of the Flame and Moth MRE was interpolated using Ordinary Kriging (OK) while this 2023 estimate for elements Ag, Au, Pb and Zn used Inverse Distance Squared (ID²). The report for the 2015 MRE of Flame and Moth reports rotations and ranges of correlograms that were determined for each zone (rather than individual vein). Sills and ranges determined were around 20% nugget, with ranges of 70 and 100 in the X direction for Ag and Pb, along with 5% nugget, with ranges of 40 and 80 for Zn.

11.2.8 BLOCK MODEL VALIDATION

11.2.8.1 Block Model Validation for the Bellekeno Deposit

Multiple model validation techniques run on the Bellekeno resource model included running an ID² and NN estimate on the same block size and parameters as the OK estimate. The difference in estimation results between the OK versus ID², and OK versus NN techniques was largely with ± 5 to 10%, as shown in Table 11-47 and Table 11-48.

Table 11-47 – Comparison Statistics for Ordinary Kriging Estimate versus Inverse Distance Squared Estimate (Alexco, 2021b).

Vein	Commodity	OK Mean *	ID ² Mean *	% Difference*
SW	Silver (g/t)	333	323	3%
	Lead (%)	3.71	3.5	6%
	Zinc (%)	3.64	4.06	-12%
99	Silver (g/t)	662	643	3%
	Lead (%)	4.16	4.06	2%
	Zinc (%)	2.72	2.63	3%
East	Silver (g/t)	190	233	-22%
	Lead (%)	1.26	1.33	-6%
	Zinc (%)	2.74	3.48	-27%

* Mean values for this comparison were generated using Snowden Supervisor software. Values are compared by number of blocks populated, not volume estimated.

** % Difference is (Ordinary Kriging Mean – Inverse Distance Squared Mean)/ Ordinary Kriging Mean * 100.

Table 11-48 – Comparison Statistics for Ordinary Kriging Estimate versus Nearest Neighbor Estimate (Alexco, 2021b).

Vein	Commodity	OK Mean *	NN Mean *	% Difference**
SW	Silver (g/t)	333	307	8%
	Lead (%)	3.71	3.53	5%
	Zinc (%)	3.64	3.26	10%
99	Silver (g/t)	662	658	0%
	Lead (%)	4.16	4.1	1%
	Zinc (%)	2.72	2.69	1%
East	Silver (g/t)	190	193	-1%
	Lead (%)	1.26	1.44	-14%
	Zinc (%)	2.74	2.69	2%

* Mean values for this comparison were generated using Snowden Supervisor software. Values are compared by number of blocks populated, not volume estimated.

** % Difference is (Ordinary Kriging Mean – Nearest Neighbor Mean)/ Ordinary Kriging Mean * 100.

A second de-clustered Nearest Neighbor block model, with a block size of 1.5 m x 1.5 m x 1.5 m, was generated for each vein and commodity using the same search orientation as the Ordinary Kriging model. Visual and numerical comparisons were run for each vein and each of silver, lead, and zinc, and results comparing the mean values are displayed in Table 11-49.

Table 11-49 – Comparison Statistics for Ordinary Kriging Estimate versus De-clustered Nearest Neighbor Estimate (Alexco, 2021b).

Vein	Commodity	OK Mean *	NN Mean *	% Difference**
SW	Silver (g/t)	350	365	-4%
	Lead (%)	3.99	4.18	-5%
	Zinc (%)	4.06	4.11	-1%
99	Silver (g/t)	689	717	-4%
	Lead (%)	4.5	4.8	-7%
	Zinc (%)	3.42	3.55	-4%
East	Silver (g/t)	205	206	0%
	Lead (%)	1.46	1.54	-5%
	Zinc (%)	3.83	3.59	6%

* Means for this comparison were generated using Hexagon Mining's Reserves tool and differ slightly from the mean values generated using Snowden Supervisor software. Mean values displayed here are compared on a volumetric basis between each other, and with the vein solids used to generate each estimate. These values are a better representation of the final grades.

** % Difference is (Ordinary Kriging Mean – De-clustered Nearest Neighbor Mean)/ Ordinary Kriging Mean * 100.

11.2.8.2 Block Model Validation for the Lucky Queen Deposit

The block model was validated visually by the inspection of successive section lines to confirm that the block model correctly reflects the distribution of high-grade and low-grade samples.

Trend analysis for the Lucky Queen Mineral Resource estimate demonstrated a minimal global bias and slight smoothing of the ID² estimates as compared to a NN estimates, and correctly reflected grade trends along the strike of the deposit (Figure 11-33). An additional validation check was completed by comparing the undiluted ID² estimates to undiluted NN estimates generated using the same search criteria and tabulated at a zero cut-off (Table 11-50). The observed difference between two models' average block estimates is a function of the sharp grade drop immediately adjacent to the high-grade core of the vein.

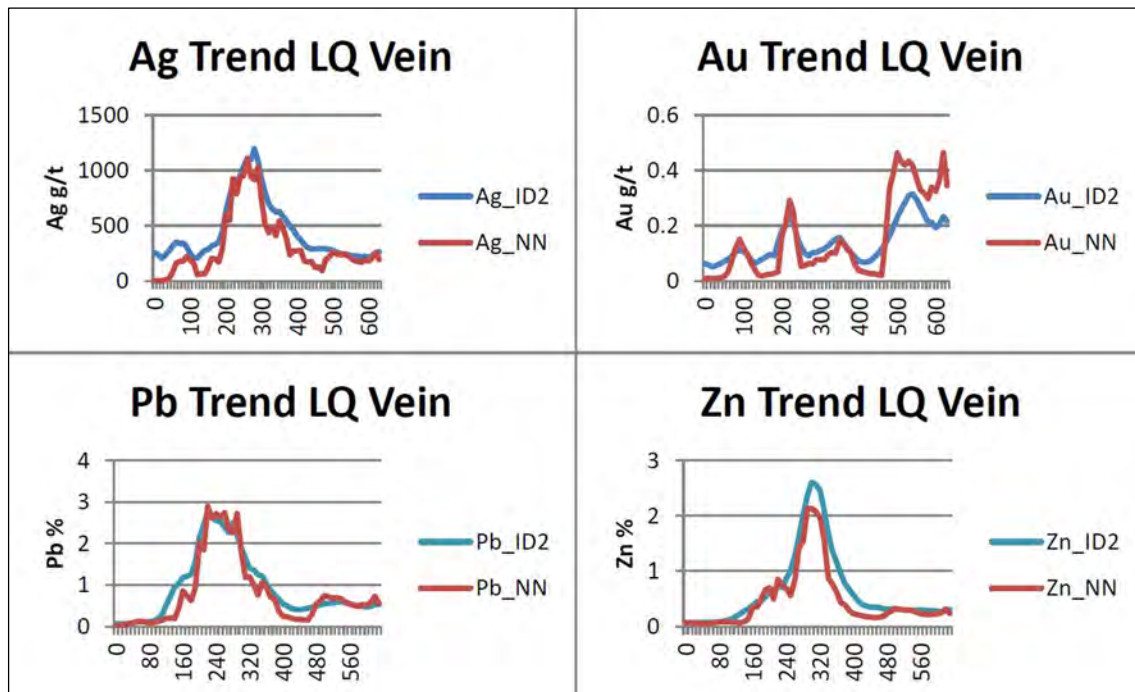

Figure 11-33 – Swath Plots Comparison of ID2 and NN Estimation (SRK, 2011a).

Table 11-50 – Lucky Queen Nearest Neighbor Block Model Validation (Alexco, 2021b).

Variable	Inverse Distance Block Average	Nearest Neighbor Block Average
Ag (g/t)	545	452
Au (g/t)	0.14	0.15
Pb (%)	1.22	1.14
Zn (%)	0.82	0.70

11.2.8.3 Block Model Validation for the Flame and Moth Deposit

The Flame and Moth 2023 mineral estimate was validated by the following methods:

- Comparison of estimated ID grades against a NN estimation for each of the metals and domains (Table 11-51).
- A visual inspection of the local block grades and the composites used for the estimates.
- Swath plots for a global validation between ID² and NN estimates.

For model validation, Mining Plus produced swath plots to validate its internal processes. Observations revealed a consistent correlation between block grades and input composite grades, with a tendency for the composite grades to be lower than the block grades. The applied capping has resulted in higher grade zones displaying lower than anticipated grades in the block model, as seen in Figure 11-34, Figure 11-35

and Figure 11-36. It is therefore recommended that reconciliations in these zones be monitored to apply adjustments to the capping process should significant variations be observed.

Mining Plus concluded that there were no obvious issues with model block estimation in the 2023 estimate.

Table 11-51 – Flame and Moth Deposit Nearest Neighbor Block Model Validation (Hecla, 2023e).

Zone	Dom	Metal	Block Count	Volume	Mean	NM Mean	%Diff.	SD	CV
Lightning	sm	Ag	1,154,814	653,283	88	101	-12%	168	1.90
Lightning	sm	Pb	1,154,814	653,283	3,081	3,206	-4%	5,417	1.76
Lightning	sm	Zn	1,154,814	653,283	10,326	10,609	-3%	13,377	1.30
Lightning	sm	Au	1,154,814	653,283	0.060	0.070	-13%	0.097	1.51
Lightning	v0	Ag	122,066	39,832	329	347	-5%	337	1.02
Lightning	v0	Pb	122,066	39,832	15,664	14,403	9%	15,298	0.98
Lightning	v0	Zn	122,066	39,832	46,963	46,663	1%	45,751	0.97
Lightning	v0	Au	122,066	39,832	0.291	0.308	-6%	0.261	0.90
Lightning	vl	Ag	655,283	263,772	373	373	0%	312	0.83
Lightning	vl	Pb	655,283	263,772	9,361	9,245	1%	11,685	1.25
Lightning	vl	Zn	655,283	263,772	56,577	54,868	3%	41,831	0.74
Lightning	vl	Au	655,283	263,772	0.321	0.330	-3%	0.231	0.72
Lightning	v2	Ag	173,119	39,685	603	640	-6%	391	0.65
Lightning	v2	Pb	173,119	39,685	15,322	18,007	-15%	11,323	0.74
Lightning	v2	Zn	173,119	39,685	55,149	62,636	-12%	31,074	0.56
Lightning	v2	Au	173,119	39,685	0.347	0.354	-2%	0.221	0.64
Christal	SM	Ag	157,217	68,491	58	64	-9%	63	1.08
Christal	SM	Pb	157,217	68,491	1,618	1,914	-15%	1,360	0.84
Christal	SM	Zn	157,217	68,491	12,225	11,247	9%	9,044	0.74
Christal	SM	Au	157,217	68,491	0.059	0.059	0%	0.073	1.24
Christal	VM	Ag	393,408	169,284	547	522	5%	424	0.77
Christal	VM	Pb	393,408	169,284	22,784	22,448	1%	28,533	1.25
Christal	VM	Zn	393,408	169,284	38,552	40,183	-4%	23,517	0.61
Christal	VM	Au	393,408	169,284	0.482	0.487	-1%	0.375	0.78

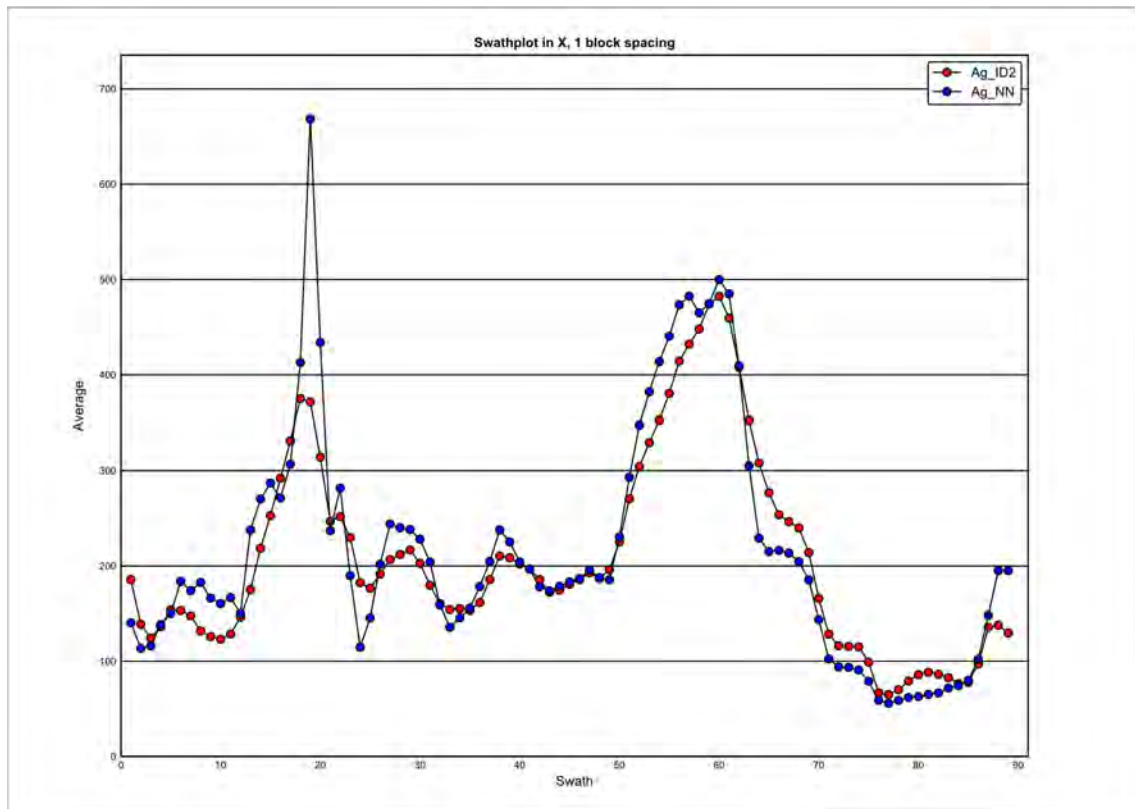

Figure 11-34 – Swath Plot Global Ag Comparison for Flame and Moth of ID2 (Red) and NN Estimation (Blue) in X Direction.

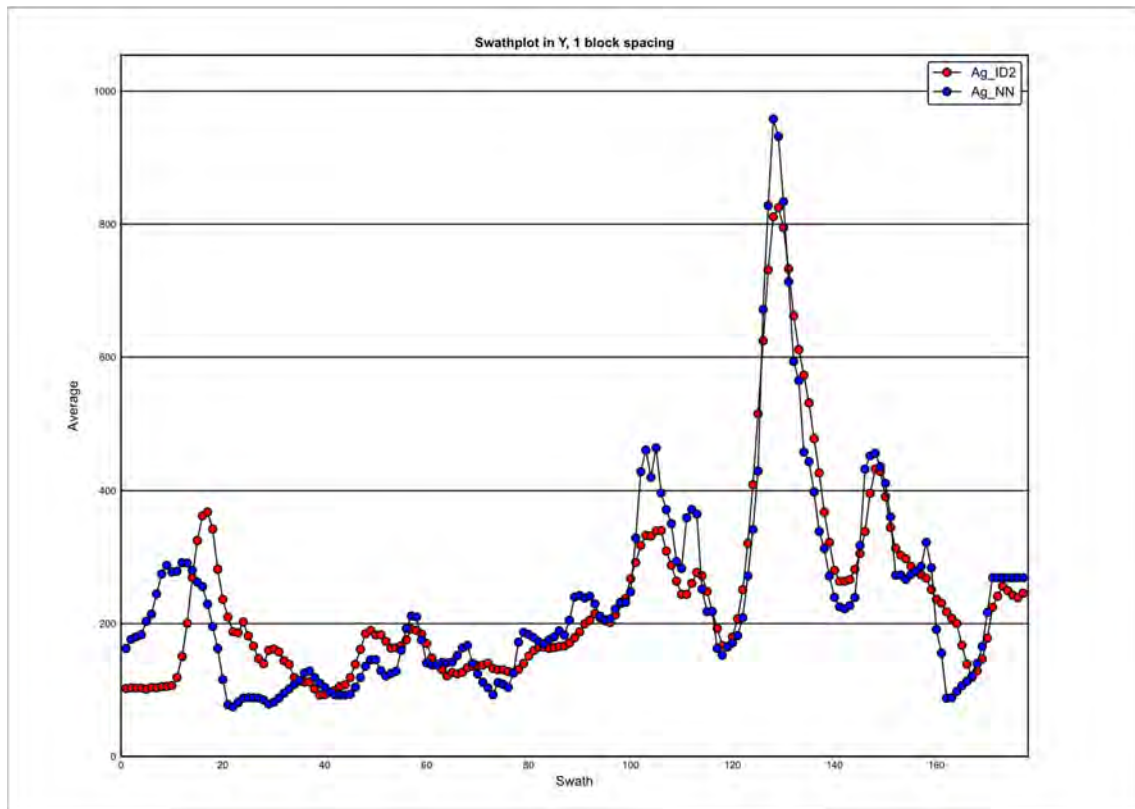

Figure 11-35 – Swath Plot Global Ag Comparison for Flame and Moth of ID2 (Red) and NN Estimation (Blue) in Y Direction.

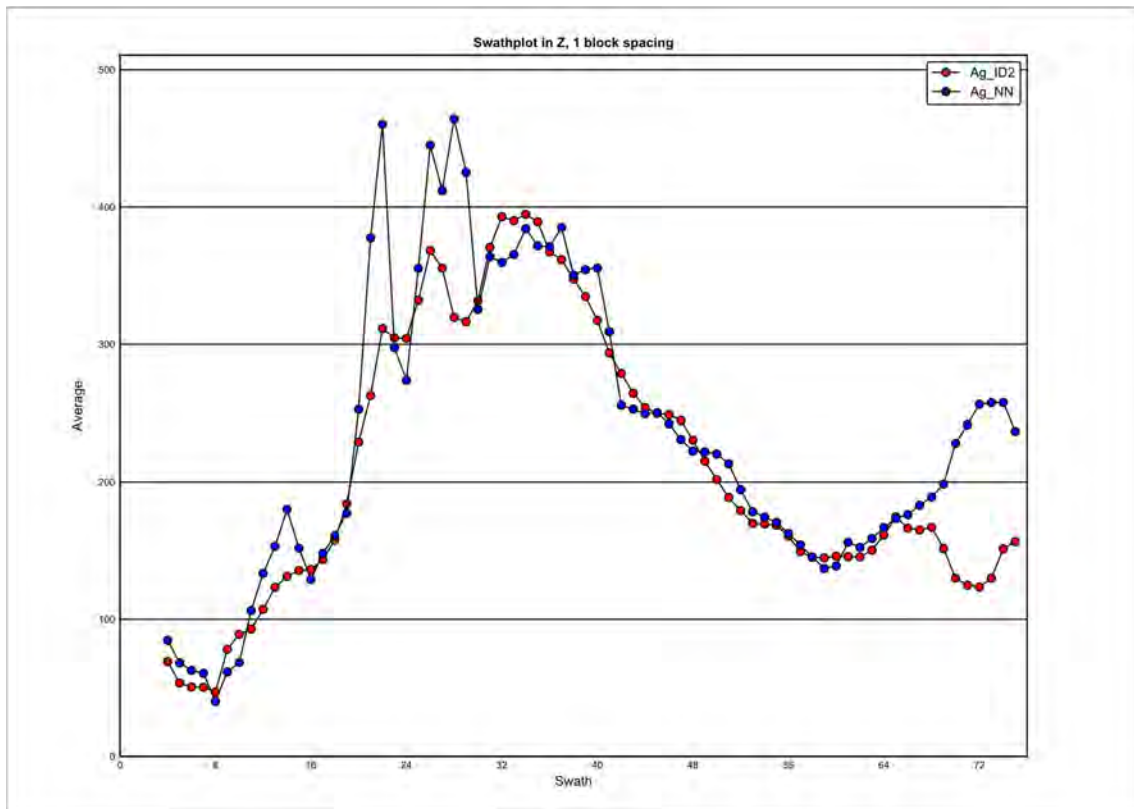

Figure 11-36 – Swath Plot Global Ag Comparison for Flame and Moth of ID2 (Red) and NN Estimation (Blue) in Z Direction.

11.2.8.4 Block Model Validation for the Onek Deposit

The block model was validated visually by the inspection of successive section lines to confirm that the block model correctly reflects the distribution of high-grade and low-grade samples. An ID² estimate was prepared for the blocks using the same search criteria and compared against the OK estimate. Analysis of OK versus ID² estimates at various cut-off values for the Onek deposit demonstrates a slight smoothing of the OK estimate compared to the ID² estimate for the indicated resource (Figure 11-37). For the inferred resource, the OK estimate for silver shows less smoothing than the ID² estimate.

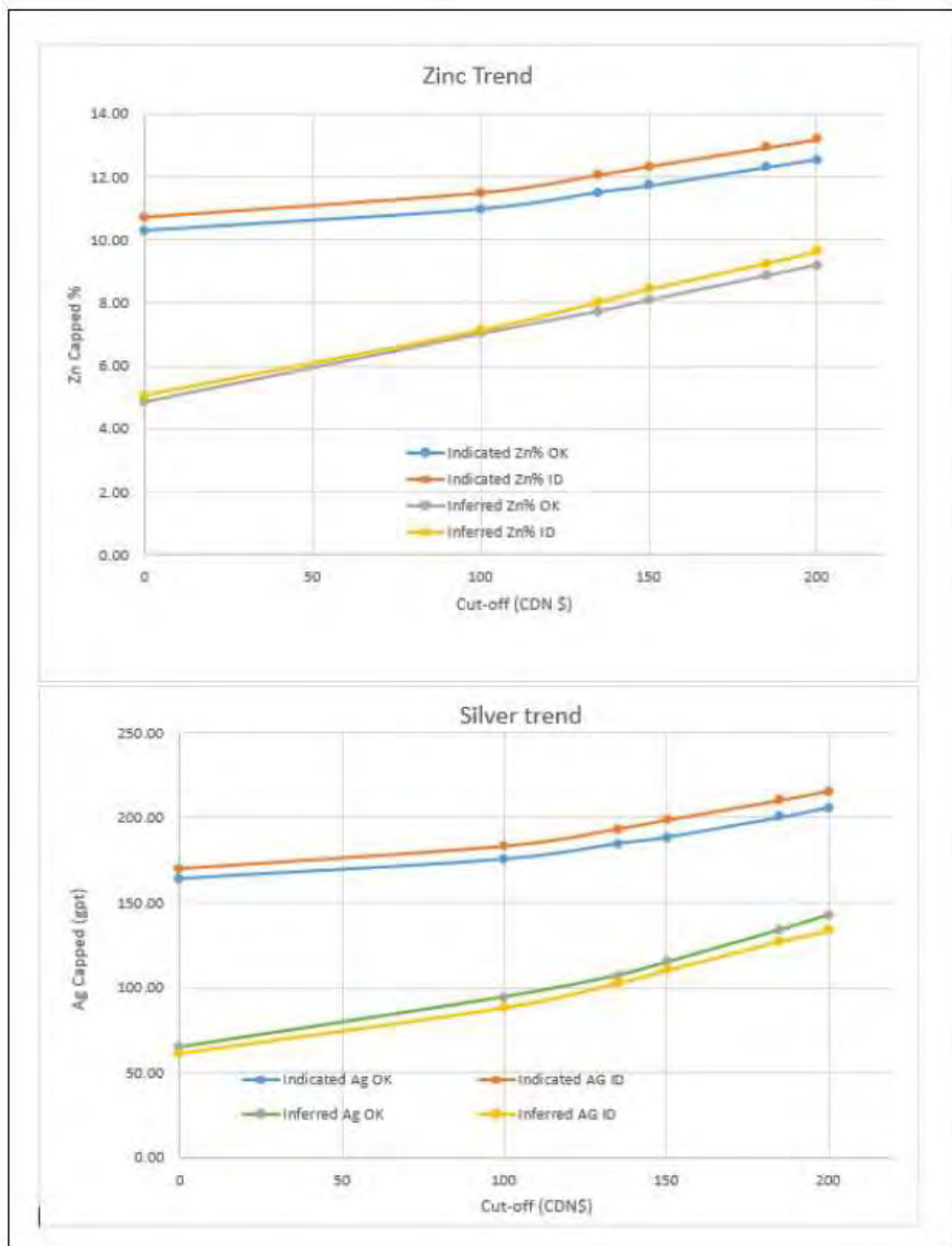

Figure 11-37 – Comparison of OK and ID2 Estimation for Onek (RPA, 2017).

11.2.8.5 Block Model Validation for the Bermingham Deposit

The 2023 Bermingham mineral resource estimate was validated by the following methods:

- Comparison of ID, KR, and NN estimates for each metal and domain summarized in Table 11-52 to Table 11-54 below.
- Visual inspection of local estimates compared to composites in both plan and cross section for each metal and domain.
- Swath plots for a global validation between ID² and NN estimates (Figure 11-38 - Figure 11-40).

Table 11-52 – Bermingham Nearest Neighbor Block Model Validation for the Arctic Zone (Hecla, 2023f).

Zone	Domain	Metal	Block Count	Volume	Mean	NN Mean	% Difference	SD	CV
Arctic	BM_VF	Ag	489,565	104,821	973.1	954.4	2%	358	0.44
		Au	489,565	104,821	0.235	0.25	-6%	0.202	0.95
		Pb	489,565	104,821	19,393	27,741	-11%	9601	0.5
		Zn	489,565	104,821	21,613	23,137	-7%	10,880	0.5
	FW_VF	Ag	322,297	71,904	1,099	1,161	-5%	703	0.64
		Au	322,297	71,904	0.206	0.218	-5%	0.095	0.46
		Pb	322,297	71,904	44,792	40,772	10%	40,354	1.15
		Zn	322,297	71,904	15,810	15,901	-1%	13,928	0.88
	BR_VF	Ag	201,447	40,738	419.2	563.9	10%	284	0.68
		Au	201,447	40,738	0.078	0.081	-4%	0.043	0.67
		Pb	201,447	40,738	10,156	9,857	3%	7,756	0.76
		Zn	201,447	40,738	9,902	10,993	-10%	4,492	0.56

Table 11-53 – Bermingham Nearest Neighbor Block Model Validation for the Bear Zone (Hecla, 2023f).

Zone	Domain	Metal	Block Count	Volume	Mean	NN Mean	% Difference	SD	CV
Bear	BM_VF	Ag	127,061	31,212	1,315	1,281	3%	1,123	0.85
		Au	127,061	31,212	0.246	0.271	-9%	0.145	0.59
		Pb	127,061	31,212	15,447	16,440	-6%	9,835	0.64
		Zn	127,061	31,212	20,063	23,807	-13%	22,110	1.10
	BR_VF	Ag	267,551	47,254	1,450	1,424	2%	1,446	1.00
		Au	267,551	47,254	0.196	0.182	7%	0.169	0.86
		Pb	267,551	47,254	32,585	40,510	-20%	35,745	1.10
		Zn	267,551	47,254	12,103	11,325	7%	10,515	0.87
	FW_sm_1	Ag	22,916	5,738	265	240	10%	162	0.61
		Au	22,916	5,738	0.094	0.093	1%	0.08	0.85
		Pb	22,916	5,738	6,771	6,586	3%	3,447	0.51
		Zn	22,916	5,738	8,758	9,817	-11%	4,976	0.57
	FW_VF	Ag	190,214	43,292	1,422	1,521	-6%	1,034	0.73

Zone	Domain	Metal	Block Count	Volume	Mean	NN Mean	% Difference	SD	CV
		Au	190,214	43,292	0.244	0.244	0%	0.177	0.72
		Pb	190,214	43,292	33,647	36,637	-8%	21,577	0.64
		Zn	190,214	43,292	28,022	26,083	7%	23,802	0.85
	BR_S_VF	Ag	30,136	6,312	2,388	2,362	1%	1,217	0.51
		Au	30,136	6,312	0.282	0.309	-9%	0.145	0.52
		Pb	30,136	6,312	70,669	78,176	-10%	47,894	0.68
		Zn	30,136	6,312	16,410	15,852	4%	14,376	0.88
	WD2_VF	Ag	10,266	2,553	649	586	11%	248	0.38
		Au	10,266	2,553	0.117	0.110	6%	0.027	0.23
		Pb	10,266	2,553	35,877	32,987	9%	9,839	0.27
		Zn	10,266	2,553	24,727	23,122	7%	6,039	0.34
	WD_VF	Ag	17,140	2,850	1,289	1,191	8%	450	0.45
		Au	17,140	2,850	0.172	0.234	-26%	0.055	0.50
		Pb	17,140	2,850	16,165	16,393	-1%	6,822	0.42
		Zn	17,140	2,850	17,332	17,419	-1%	10,593	0.61
	BR_HW_SM	Ag	62,146	13,213	174	159	10%	96	0.55
Au		62,146	13,213	0.051	0.053	-3%	0.016	0.31	
Pb		62,146	13,213	5,368	4,702	14%	2,348	0.44	
Zn		62,146	13,213	7,910	7,325	8%	4,131	0.50	

Table 1153 – Bermingham Nearest Neighbor Block Model Validation for the North East Zone (Hecla, 2023f).

Zone	Domain	Metal	Block Count	Volume	Mean	NN Mean	% Difference	SD	CV
North East	BM_VF	Ag	363,844	73,196	998	1,096	-9%	908	0.91
		Au	363,844	73,196	0.303	0.314	-3%	0.183	0.74
		Pb	363,844	73,196	28,639	30,652	-7%	27,653	0.97
		Zn	363,844	73,196	14,831	14,056	6%	20,553	1.07
	BR_VF	Ag	663,761	178,040	1,387	1,326	5%	945	0.68
		Au	663,761	178,040	0.235	0.222	6%	0.131	0.56
		Pb	663,761	178,040	48,066	42,493	13%	44,265	0.90
		Zn	663,761	178,040	17,852	17,599	1%	18,098	1.01
	FW_sm_1	Ag	169,919	30,923	498	552	-10%	488	1.13
		Au	169,919	30,923	0.12	0.126	-5%	0.058	0.56
		Pb	169,919	30,923	15,153	14,964	1%	10,182	0.67
		Zn	169,919	30,923	19,850	17,702	12%	13,350	0.67

Table 11-54 – Birmingham Nearest Neighbor Block Model Validation for the Etta Zone (Hecla, 2023f).

Zone	Domain	Metal	Block Count	Volume	Mean	NN Mean	% Difference	SD	CV
Etta	BM_VF	Ag	27,190	5,797	82	89	-8%	37	0.44
		Au	27,190	5,797	0	0	-4%	0.006	0.31
		Pb	27,190	5,797	3,562	3,449	3%	1,673	0.47
		Zn	27,190	5,797	11,975	12,574	-5%	4,470	0.37
	BR_VF	Ag	152,943	34,321	966	998	-3%	484	0.50
		Au	152,943	34,321	0	0	-9%	0.05	0.44
		Pb	152,943	34,321	42,488	39,464	8%	17,294	0.41
		Zn	152,943	34,321	29,661	29,093	2%	11,183	0.38
	FW_sm_1	Ag	39,577	9,303	109	126	-14%	93	0.86
		Au	39,577	9,303	0	0	5%	0.016	0.28
		Pb	39,577	9,303	2,548	2,838	-10%	2,662	1.04
		Zn	39,577	9,303	4,349	4,313	1%	1,105	0.25
	FW_sm_1	Ag	261,717	67,252	507	505	0%	171	0.34
		Au	261,717	67,252	0	0	4%	0.038	0.49
		Pb	261,717	67,252	14,789	14,330	3%	10,264	0.65
		Zn	261,717	67,252	22,084	21,160	4%	7,744	0.35

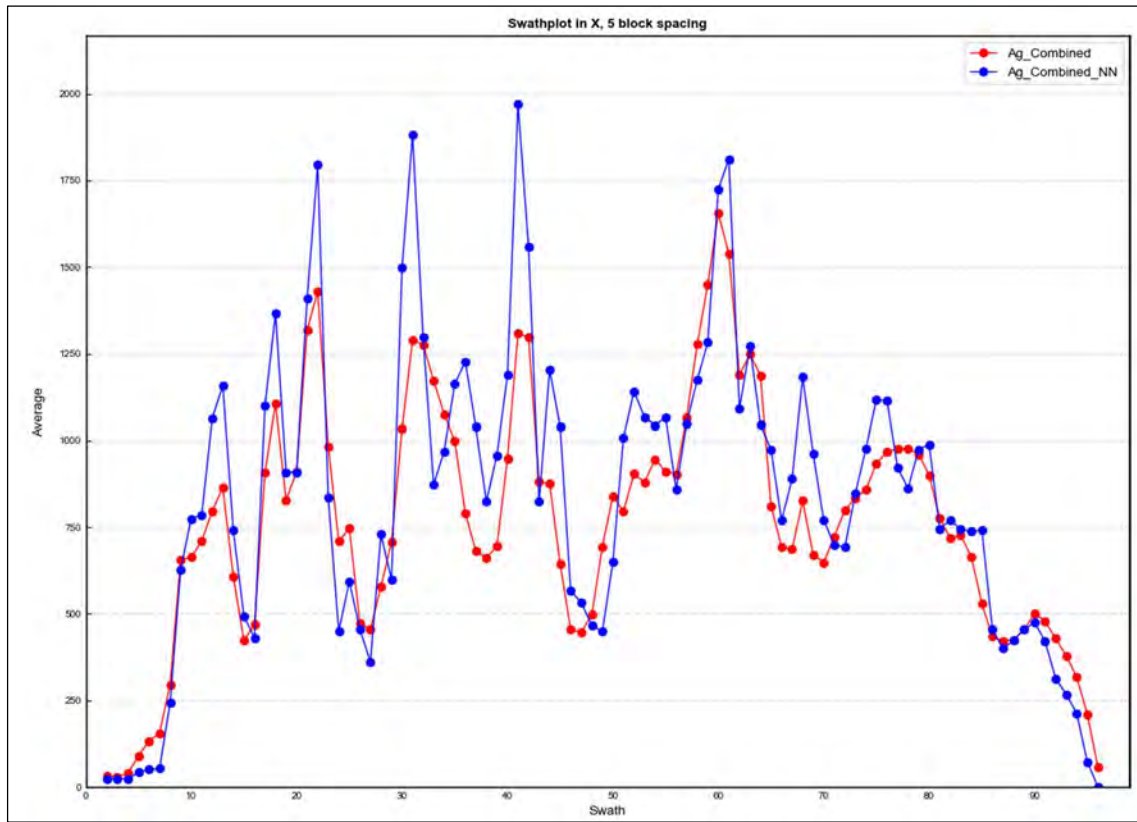

Figure 11-38 – Swath Plot Global Ag Comparison for Bermingham of ID2 (Red) and NN Estimation (Blue) in X Direction.

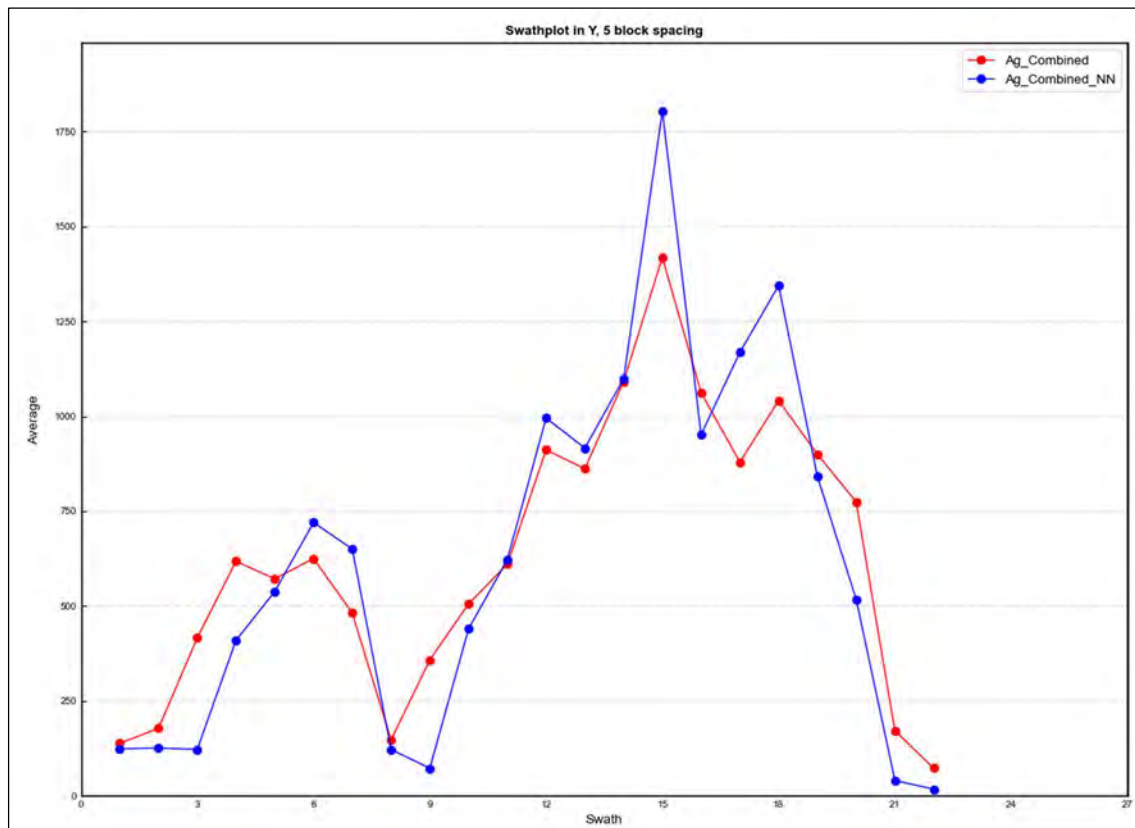

Figure 11-39 – Swath Plot Global Ag Comparison for Bermingham of ID2 (Red) and NN Estimation (Blue) in Y Direction.

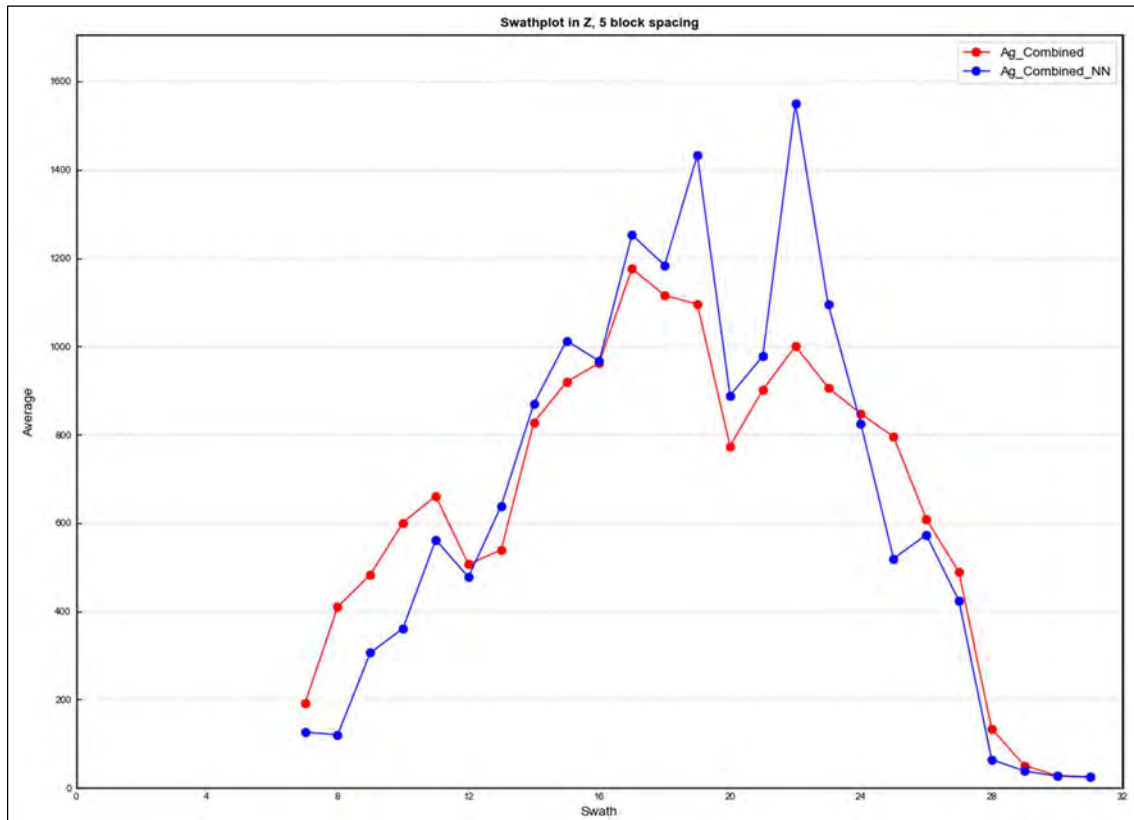

Figure 11-40 – Swath Plot Global Ag Comparison for Bermingham of ID2 (Red) and NN Estimation (Blue) in Z Direction.

11.3 MINERAL RESOURCE CLASSIFICATION

Industry best practice in Mineral Resource classification suggests that resource classification should consider both the confidence in the geological continuity of the mineralized structures, the quality and quantity of exploration data supporting the estimates, and the geostatistical confidence in the tonnage and grade estimates. Appropriate classification criteria should aim at integrating these concepts to delineate regular areas at similar resource classification.

All block models and all associated data were reviewed by the Mining Plus geology QP. The QP is satisfied that geological modelling honors the current geological information and knowledge. The location of the samples and the assay data are sufficiently reliable to support resource evaluation. Likewise, in the review of resource classification, any uncertainties related to the data, models, or estimation processes have been considered.

During the review process carried out by Mining Plus, it was noted that most blocks classified as Indicated utilize a drill spacing of approximately 25 m x 25 m across all deposits. However, variations in approaches of classification were identified, primarily attributable to different authors. Importantly, no significant discrepancies were observed except for Bellekeno, as is explained in the section below. Mining Plus

recommends maintaining the 25-meter threshold for Indicated classification, emphasizing the importance of consistent classification criteria across deposits whenever feasible.

Generally, when evaluating mineralization with strong geological continuity, investigated at an adequate drill spacing with reliable sampling information, the QP considers that blocks estimated during the first estimation run considering full variogram ranges can be classified in the Indicated category in accordance with the SEC definitions. For those blocks, the QP considers that the level of confidence is sufficient to allow appropriate application of technical and economic parameters to support mine planning and to allow evaluation of the economic viability of the deposit.

Conversely, blocks estimated during the second and third passes considering search neighborhoods set larger than the variogram ranges should be appropriately classified in the Inferred category due to insufficient confidence in the estimate. This allows for meaningful application of technical and economic parameters or to enable an evaluation of economic viability.

The Mineral Resources were estimated in conformity with the SEC S-K 1300 regulations, and all Mineral Resource Estimates presented in this updated technical report have been classified within the meaning of the SEC definitions by independent QP's.

Mineral Resources may be affected by further infill and exploration drilling that may result in increases or decreases in subsequent resource estimates. Mineral Resources may also be affected by subsequent assessments of mining, environmental, processing, permitting, taxation, socio economic, and other factors.

11.3.1 MINERAL RESOURCE CLASSIFICATION FOR THE BELLEKENO DEPOSIT

Block model quantity estimates, grade estimates, and resource classification for the Bellekeno deposit were prepared by Alexco Resource Corp.

The initial Mineral Resource Classification for this block model in 2022 categorized blocks as Indicated Mineral Resources if at least four drill holes within 50 m, and a kriging variance less than 0.5 was obtained. Blocks were classified as Inferred Mineral Resources if at least two drill holes within 100 m, and a kriging variance less than 0.85 was obtained. Due to the limited data in the East Vein, no Indicated Mineral Resource existed for the East Vein. All other blocks remained unclassified.

Upon review by the Mining Plus geology QP, several inconsistencies between the block model and raw data were detected and have not been sufficiently resolved. Incomplete or unclear data did not allow for exact replication; additionally, certain domains exhibited an apparent overestimation of zinc (domain 991 and 481) and silver (smallest domain 481). Density calculations are derived from the grades of silver, lead and zinc, posing a potential for overestimation in these domains. Reasons behind this overestimation remain unclear and necessitate further investigation. It is important to highlight that the resource contribution at Bellekeno constitutes a small percentage (4%) of silver ounces in comparison to the global

resources, and any potential issues associated with this deposit are not deemed material. This has resulted in the downgrade of all indicated to inferred resources. The existing inferred resource has not changed status and unclassified blocks remain unclassified. Nevertheless, it is advised to undertake a new resource estimate, taking into consideration the noted discrepancies.

All blocks estimated in the first estimation run were classified as Inferred Mineral Resources along with all blocks from subsequent estimation runs for this report.

11.3.2 MINERAL RESOURCE CLASSIFICATION FOR THE LUCKY QUEEN DEPOSIT

Block model quantity estimates, grade estimates, and resource classification for the Lucky Queen deposit were prepared by F. H. Brown, CPG, PrSciNat, under the supervision of Dr. Gilles Arseneau, P.Geo. The Mining Plus geology QP reviewed the block model and all associated data.

The Mining Plus geology QP considers that the quality of the exploration data (confidence in the location and reliability of assaying results) is good and, therefore, is not a factor that would impact resource classification. The confidence in the underlying data sets supports the classification of Indicated and Inferred Mineral Resources. There is insufficient information to confirm both the geological and grade continuity with the current level of sampling to support a Measured Mineral Resource classification.

All blocks estimated in the first estimation run were classified as Indicated Mineral Resources and all blocks estimated using the second estimation run were classified as Inferred Mineral Resources.

11.3.3 MINERAL RESOURCE CLASSIFICATION FOR THE FLAME AND MOTH DEPOSIT

Block model quantity estimates, grade estimates, and resource classifications for the Flame and Moth deposit were prepared by Ben Chambers, Resource Geologist, Hecla. The block model and all associated data was reviewed by the Mining Plus geology QP.

Block classification hinged on proximity to drillholes and available sample data. The majority of Indicated category blocks drew data from two drill holes, ensuring an approximate drill spacing of 25 m x 25 m. and a minimum of 6 samples for estimation. After this initial review, hand drawn outlines were created to clean up any artifacts and remove instances of “spots” within the model. These outlines were extruded through the mineralized domains and used to classify the material.

Mining Plus remains in agreement with the applied classification and further recommends that the 25 m threshold for Indicated is maintained.

The removal of the closer spaced samples in the already mined area remains a concern. The samples obtained from these mining areas, in conjunction with completed geology mapping may permit sufficient control to classify some of the resource estimate as Measured.

11.3.4 MINERAL RESOURCE CLASSIFICATION FOR THE ONEK DEPOSIT

Block model quantity estimates, grade estimates, and resource classification for the Onek project were prepared by Dr. Gilles Arseneau, P. Geo, who is an independent QP. The block model and all associated data was reviewed by the Mining Plus geology QP.

The Mining Plus geology QP considers that the quality of the exploration data (confidence in the location and reliability of assaying results) is good and therefore is not a factor that would impact resource classification. The classification of Indicated and Inferred Mineral Resources was applied to the Onek deposit based on a full review that included the examination of drill spacing, visual comparison and distance to nearest drillhole. There is insufficient information to confirm both the geological and grade continuity with the current level of sampling to support a Measured Mineral Resource classification.

Blocks were classified as Indicated Mineral Resources if at least two drill holes and five composites were found within a 60 m by 30 m search ellipse. All other interpolated blocks were classified as Inferred Mineral Resource. Similar to previous deposits, block classification relied on the proximity to drillhole data and available sample information. The majority of Indicated classified blocks use approximately 25 x 25 m spacing drilling.

11.3.5 MINERAL RESOURCE CLASSIFICATION FOR THE BIRMINGHAM DEPOSIT

Block model quantity estimates, grade estimates, and resource classification for the Birmingham deposit were prepared by Ben Chambers, Resource Geologist, Hecla. The block model and all associated data was reviewed by Mining Plus geology QP.

The Mining Plus geology QP assesses that the exploration data's quality, reflecting both confidence in the spatial accuracy and reliability of assaying results, is deemed satisfactory and, consequently, does not constitute a determinant affecting the resource classification. The classification methodology applied to the Birmingham deposit relied on computing the average distance to drillholes utilized in the estimate. Final delineations were formulated by considering the density of drilling information and the level of confidence in the geologic interpretation.

Material exhibiting the highest confidence level is categorized as Indicated, with the initial selection determined during the first pass. Subsequent adjustments to boundaries are made based on proximity to drilling sites and the associated geological confidence.

11.4 DEPLETION

All five block models for the deposits within the Keno Hill Project were depleted using underground void wireframes. Depletion at the Bellekeno deposit was completed and inclusive to the end of 2021 with no additional mining having taken place since. Challenges encountered during the depletion process included topographical triangulation issues and uncertainties in recent MRE updates, both of which complicated the depletion process. The depletion was facilitated with the aid of a bubble wireframe, incorporating a 5.0 m buffer around the underground voids.

The Lucky Queen and Onek Mines experienced complete depletion of mineral production by the conclusion of 2017. Post-2017 mining endeavors in these mines were primarily focused on rehabilitation efforts. Flame and Moth and Bermingham, both undergoing active mining, were depleted as of the conclusion of September 2023 and end of December 2023, respectively. Updated underground drift and stope voids were used for this process.

Figure 11-41 shows the underground workings along with the wireframe used during the depletion process at Bellekeno.

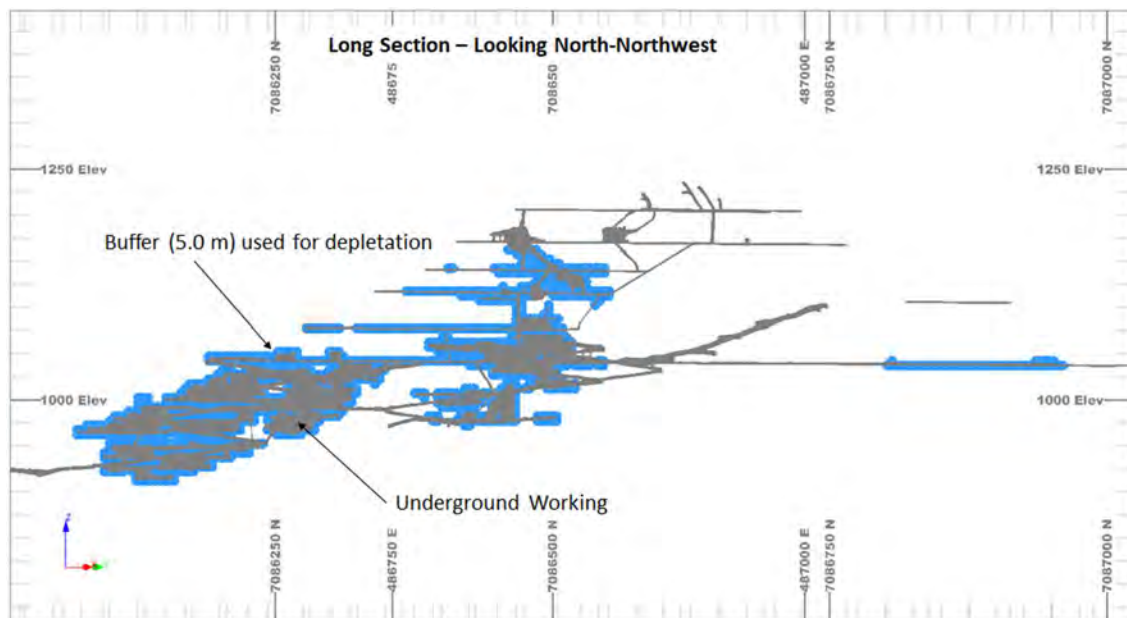

Figure 11-41 – Bellekeno Mine Long Section, Underground Working Wireframes, Looking North-Northwest.

11.5 BASIS FOR ESTABLISHING THE PROSPECTS OF ECONOMIC EXTRACTION FOR MINERAL RESOURCES

An optimization was carried out at SMU using Surpac software to determine the extent of the mineral resource with "reasonable prospects for eventual economic extraction" in all five of the deposits using the cut and fill method to satisfy the requirement in accordance with industry standards.

Mining Plus performed a resource optimization in accordance with the economic parameters and stope dimensions detailed in Table 11-55 using an NSR cut-off of CAD \$185/tonne. All the Mineral Resources are reported inside the optimized underground shell.

The NSR cut-off of CAD \$185/tonne is derived from past studies focusing on mining and mill process costs. Hecla's current assessment suggests that, based on their updated cost analysis, the NSR cut-off should be around CAD \$200/tonne. Hecla's comparisons of reported resources at the two cut-off levels indicate no significant differences. Mining Plus has independently reviewed the results and concluded that the difference in cut-off values is not deemed material.

In the resource optimization process for Bellekeno, Lucky, and Onek, a modification was sub-cells in the block model. This adjustment aimed to transition from a block model with regular cell size and a percentage representation of the mineral zone to a block model with sub cells. Mining Plus conducted a thorough examination of the outcomes of the model with sub cells and identified a discrepancy in the Onek model. Despite this inaccuracy, it is deemed non-material for the reported resources due to location and quantity. Mining Plus strongly recommends the need to update these models in a consistent, traceable, and practical manner for operational purposes.

Table 11-55 – Assumptions Considered for Preparing the 2023 Mineral Resource Estimates at Keno Hill.

Parameter	Bellekeno, Onek, Lucky Queen	Flame and Moth, Bermingham	Unit
Silver price	21	21	USD per oz
Gold price	1,750	1,750	USD per oz
Lead price	1.15	1.15	USD per lb
Zinc price	1.35	1.35	USD per lb
Exchange rate	1.3	1.3	CAD/USD
NSR cut-off value	185	185	CAD per tonne mined
Minimum mining width	1.5	1.5	metres
Process recovery silver	93	96	%
Process recovery gold	25	25	%
Process recovery lead	93	93.24	%
Process recovery zinc	72	72	%

11.6 MINERAL RESOURCE STATEMENT

The Mineral Resources have been estimated in compliance with the Securities and Exchange Commission requirements (SEC, 2018) and are reported in accordance with S-K 1300 regulations. Mineral Resources are not Mineral Reserves and do not have demonstrated economic viability.

In the opinion of the QP, the resource evaluations reported herein are a reasonable representation of the global polymetallic Mineral Resources in the Bellekeno, Lucky Queen, Flame and Moth, Onek, and Bermingham deposits given the current level of sampling.

As noted by Mining Plus, there has been no substantial alteration in Indicated resources on a global scale, notwithstanding the degradation of Indicated resources from Bellekeno to Inferred and the depletion of Flame and Moth and Bermingham. Nevertheless, there has been a notable upswing in Inferred resources, amounting to a 30% increase. While it is important to acknowledge that the previous models are not directly comparable, these significant changes primarily stem from five factors:

- New drilling primarily at Flame and Moth and Bermingham.
- New vein interpretations at Flame and Moth and Bermingham deposits.
- New metal prices that are generally higher, according to long-term updated prices.
- For the reporting of Mineral Resources, optimized underground shells were generated utilizing a cut-off of CAD \$185/tonne with a minimum mining width of 1.50 m, and all the Resources were subsequently reported within these specific underground shells; in comparison to previous resources that were reporting on an NSR cut-off.
- Depletion at Flame and Moth and Bermingham with the mining production.

11.7 MINERAL RESOURCE UNCERTAINTY DISCUSSION

Possible risk factors together with the rationale for the approach taken or mitigating factors established to reduce any risk are described below:

- a) Data: Although no material inconsistencies have been detected, the flagging of NR (No record or NULL) assay data is noted and has been left as NULLs in the estimation process. This is standard practice; however, it was noted that many are located within low grade zones (zones for Christal and Lightning in Flame and Moth) so it may not have a significant impact on the resources. At Flame and Moth, it was noted that the NR intervals constituted around 15% of the total sampled length of some domains and monitoring of these zones is recommended.

The examination of various drilling databases revealed some minor inconsistencies that should be appropriately addressed in future efforts. Among these, the most crucial issues included the lack of consistency in logging information prior to 2010 and discrepancies observed between the entered assay data and the laboratory certificates, particularly notable in the Onek database, and to a lesser extent at Bellekeno and Lucky Queen. While the discrepancies identified in the database review are minor, conducting a more comprehensive audit is imperative to address

these inconsistencies and ascertain whether any other issues exist that may not have been uncovered in Mining Plus's initial review.

Density determination was conducted using the pycnometer applied to the pulp. This method is widely employed in most cases for density calculations through regression functions with metal content. It is important to note that, to eliminate biases associated with the pycnometer, a comparison was made with density obtained through the Archimedes method. While no significant bias was detected, Mining Plus suggests that the Archimedes method may require improved measurement accuracy, particularly in porous or vuggy areas. To address this, it is recommended to compare the Archimedes method using a paraffin coating or to engage an external laboratory in these areas to ensure the absence of any density biases.

- b) **Geologic Model:** This aspect is considered critical as different models can be interpreted under different criteria or perspectives, being the main risk associated with any project. The applied interpretation and modelling criteria seem to vary from deposit to deposit. The interpretations are apparently based on a combination of geology and economic cut-off and a lack of accurate snapping was observed in some deposits. These problems may not have a significant global impact on the resource but there could be some impact at a local scale. It is advisable to have clear and consistent modeling criteria for any future updates.

Some logging inconsistencies have been detected for holes prior to 2010 that can, in some cases, generate a misinterpretation. It is therefore suggested to review the logging carried out in the estimation domains for future estimates.

- c) **Classification Criteria:** Classification appears to have been applied to a reasonable standard, with most blocks within 25 m of source data being assigned Indicated status. However, it was noted that the classification scheme for many deposits is around 50-m distance for the Indicated classification, which is typically wider than what would normally be applied. Furthermore, the classification criteria include uncertainty in the data and estimate due to discrepancies found in the revision made by Mining Plus as in the case of Bellekeno.

- d) **Grade Capping:** The implementation of capping has been applied on a case-by-case basis and as needed. Overall, most estimation domains exhibit a low coefficient of variation (CV). For Flame and Moth, a clamp method was employed to limit high-grade values. Whilst this results in lower than anticipated grades in high grade zones, this method shows improved results compared to traditional capping methods. Mining Plus holds the opinion that there are no notable concerns regarding the outcomes of capping; nevertheless, it is recommended that a consistent capping method be applied uniformly across all five deposits and the domains with high CV are reviewed to detect subpopulations.

Mining Plus advises against methods of raw data capping, as it may result in potentially higher loss of metal compared to capping on the composite. The recommended approach is to consider capping after the compositing process, where the influence of high grades is mitigated.

- e) Interpolation of the Grades: Block model grade interpolation was completed with different estimation techniques to accommodate local and global biases, which currently remain within the acceptable range. No material issue was detected with the exception of the Bellekeno deposit, which was subsequently downgraded from Indicated classification to Inferred. However, it was noted that different estimation approaches have been applied to each deposit due to differing authors. Future estimates should establish consistent estimation criteria as far as practicable, which includes capping methods, density estimates, and classification criteria among others. The implementation of mining reconciliation is currently ongoing, and a comprehensive review is underway to grasp all the components involved and comprehend potential differences. Mining Plus emphasizes that, in accordance with best practices, mining reconciliation stands out as a tool with the potential for achieving superior results in validation. It plays a crucial role in enhancing an understanding regarding the certainty of Mineral Resources and anticipating future improvements.

- f) Processing and Mining Costs: Mining Plus has assumed no risk for the processing and mining costs applied to the NSR economic cut-off for reporting the Mineral Resource estimates. These costs have been reportedly based on previous studies. However, verification with current Hecla costs (mining and processing cost) showed no significant differences in the reported resources.

- g) Metal Price Assumption: The assumptions are deemed reasonable for reporting Mineral Resources considering long-term prices over the last decade. Nonetheless, it is essential to acknowledge that these parameters could be influenced by significant shifts in the market economy.

It is the opinion of the Mining Plus geology QP that the Mineral Resource models presented in this report are representative of the informing data and that the data is of sufficient quality and quantity to support the Mineral Resource estimate to the Classifications applied.

12. MINERAL RESERVE ESTIMATES

This section describes the methodology and parameters used to estimate the Mineral Reserves for the Keno Hill Mine.

Mineral Reserves are those parts of Mineral Resources, which, after the application of all modifying factors, result in an estimated tonnage and grade that is the basis of an economically viable project. Mineral Reserves are inclusive of diluting material that will be mined in conjunction with the economically mineralized rock and delivered to the treatment plant or equivalent facility. The term “Mineral Reserve” need not necessarily signify that extraction facilities are in place or operative, or that all governmental approvals have been received. It does signify that there are reasonable expectations of such approvals.

The current Mineral Reserve Estimate, as prepared by Hecla and reviewed and accepted by Mining Plus, is effective as of December 31, 2023, considers all information used in the Mineral Resource Estimate presented in Section 11.1, and is summarized in Table 12-1.

Only Measured and Indicated Mineral Resources were converted to Mineral Reserves. Any Inferred Mineral Resources included within the Mineral Reserve designs are carried at zero grade.

Table 12-1 – Summary of Mineral Reserves – December 31, 2023 – Hecla Yukon – Keno Hill Mine.

Deposit	Class	Volume (m ³)	Mass (t)	Ag (g/t)	Pb (%)	Zn (%)	Au (g/t)	Ag (oz)
Lucky Queen	Proven							
	Probable	37,055	103,365	948	2.03	1.06	0.09	3,151,253
Flame and Moth	Proven							
	Probable	136,334	455,244	764	2.86	5.83	0.48	11,184,405
Birmingham	Proven							
	Probable	438,155	1,318,748	961	2.85	1.51	0.15	40,732,370
Total	Proven							
	Probable	611,544	1,877,357	912	2.81	2.53	0.22	55,068,028

Notes:

- Classification of Mineral Reserves is in accordance with the S-K 1300 classification system.
- Mineral Reserves were estimated by Hecla and reviewed and accepted by Mining Plus.
- The point of reference for the Mineral Reserves is defined at the point where the ore is delivered to the processing plant.
- Mineral Reserves are 100% attributable to Hecla.
- Mineral Reserves are estimated at an NSR cut-off value of CAD 350/tonne.
- The NSR values reflect the discrete metallurgical responses for the Mineral Reserve blocks.
- Mineral Reserves are estimated using metallurgical recoveries of 92.0% Ag, 25% Au, 4.0% Zn and 88% Pb for the silver lead concentrate and 5.24% Ag, 0% Au, 68% Zn and 4.0% Pb for the Zinc concentrate.
- Mineral Reserves are estimated using long-term silver price of USD 17.00/oz, lead price of USD 0.90/lb, zinc price of USD 1.15/lb and a CAD:USD exchange rate of 1.30.
- A minimum mining width of 3.5 m was used for all assets.
- Rounding as required by reporting guidelines may result in apparent summation differences between tonnes, grade and contained metal content.

The Mineral Reserve metal prices were established mid-year 2023 based on the following:

- Hecla’s historic price decks for year-end 2022 Mineral Reserves and Resources, 2024 Long-Range Plans and 2023 budgets.
- Bloomberg Historical prices from June 26, 2023.
- Future prices from Consensus Economics from June 26, 2023.
- Wood Mackenzie Short Term Outlook reports for July 2023.
- Year-end 2022 Mineral Reserve metal price for selected peer and other companies.

Mining Plus’s QP is of the opinion that the Mineral Reserve prices for silver and gold are moderately conservative when compared against third-party economics firm’s long-term consensus pricing. The zinc and lead price are near the mean when compared against third-party economics firm’s long-term consensus pricing.

Detailed information on mining, processing, and other relevant factors are contained in the following sections and combined to demonstrate that the Keno Hill Mine is economically viable.

12.1 MINERAL RESERVE ESTIMATE METHODOLOGY

Mechanized cut and fill (MCF) mining method is used in this Mineral Reserve Estimate and detailed in Section 13.3.1.

Production designs are created based on the geometries relevant to the cut and fill mining method which are discussed in Section 13.3.1. Mineral Reserve Estimates are based on the Mineral Resource 3D block models. Mineable shapes are created based on individual zones and lens geometries around the production locations that meet the NSR cut-off threshold, while also ensuring that adverse pillar geometries are not created that could become unstable, and that mining does not cease near a problematic structure. Production locations outside the Mineral Reserve outlines are not included in Mineral Reserves. Once designs are completed, access ramps and other supporting infrastructure are designed to facilitate production mining.

The production design wireframes are evaluated against the sub-blocked model to generate tonnes and grades for each location.

Internal portions of the mineralized zones that did not meet the NSR cut-off grade value are treated as waste. This mineralized material could be included in the mineable shapes and the Mineral Reserves by applying a marginal cut-off grade as the material will have to be mined to gain access to other areas of the Mineral Reserve. The Mining Plus mining QP recommends that the material be evaluated for inclusion in the Mineral Reserves for any future updates.

12.2 NET SMELTER RETURN AND CUT-OFF GRADE

The primary saleable metal of Keno Hill is silver with lead and zinc as significant byproducts. Gold is also present and recovered to the concentrate, however, it is not payable under the current smelter contract and does not contribute to the NSR value. As is typical of polymetallic deposits, the cut-off grade (COG) for Mineral Reserves is calculated and expressed in terms of Net Smelter Return (NSR) value per tonne. The NSR is calculated on a unit metal value basis using representative smelter contract terms, freight costs, and forecast metal prices. Metal prices and metallurgical recoveries used to calculate NSR are summarized in Table 12-2 and Table 12-3.

Table 12-2 – Metal Prices Used in NSR Calculation.

Product	Unit	Price
Silver (Ag)	USD/oz	17.00
Lead (Pb)	USD/lb	0.90
Zinc (Zn)	USD/lb	1.15
Exchange Rate	CAD/USD	1.30

Note: Hecla 2023 End of Year Reserve Pricing (Gold (Au) excluded)

Table 12-3 – Representative NSR Parameters.

NSR Assumptions	Unit	Ag-Pb Concentrate	Zn Concentrate
Recovery			
Ag	%	92.0	5.24
Au	%	25.0	0.0
Zn	%	4.0	68.0
Pb	%	88.0	4.0
Concentrate Grade			
Ag	g/t	19,268.8	1997.0
Au	g/t	0.7	0.0
Zn	%	1.2	47.0
Pb	%	45.0	6.4
Moisture Content	%	10	10
Payability			
Minimum Deductible Ag	grams/DMT of concentrate	50	93
Minimum Deductible Pb/Zn	%	3	8
Payable Ag after Deductions	%	95	70
Payable Pb/Zn after Deductions	%	95	85

NSR Assumptions	Unit	Ag-Pb Concentrate	Zn Concentrate
Charges			
Total charge (concentrate treatment, freight, refining)	USD/WMT of Concentrate	382.31	522.31

Note: preliminary recoveries, concentrate grades, payment terms and charges available at the time of mine planning, used for the design only.

The COG value used for mineable shapes evaluation is CAD 350.00/tonne. This COG reflects the property-wide operating costs distributed on a per-tonne basis. The Keno Hill operating costs used as the basis for cut-off grade calculations are presented in Table 12-4.

Table 12-4 – Keno Hill Mine Cut-off Values by Cost Area

Description	Mining	Mill	G&A	Total
Operating Costs (CAD/t)	180	62	108	350

Mining Plus independently verified the Mineral Reserve NSR estimation methodology. Variances were noted in the application of the metal prices between the NSR build up for the Mineral Reserve Estimate and the prices used for economic evaluation. The economic evaluation is based on higher assumed metal prices supported by end of year 2023 long term metal price forecasts and consensus reporting.

12.3 DILUTION

Dilution refers to material below cutoff grade or value which must be mined because it cannot be selectively excluded from within the planned mining shapes at the time of excavation. This low-grade material is also typically referred to as internal dilution. Dilution is impossible to avoid due to the narrow geometry of the orebody.

In the cut and fill design stage, in many cases, the shapes of the planned excavation cannot be perfectly matched to the mineralized outlines. Areas outside of the mineralized outline, but inside the planned development are typically referred to as planned dilution and must be excavated for technical and operational reasons. In addition to the above-planned dilution, dilution can result from additional material that is mined as a result of uncontrolled, unplanned, or unforeseen reasons. This material is often referred to as overbreak, unplanned dilution, or external dilution.

Accurate reconciliation studies are required to estimate the tonnage and grade of the planned and unplanned dilution in an underground mine. The tonnage of the unplanned dilution can be measured by comparing the excavated volume of a given cut and fill shape to the planned or designed volume. The grade of the planned and unplanned diluting materials can be estimated from the available sample information. The volume of the secondary dilution can be estimated by comparing the surveyed

excavation shape of the backfilled development with the surveyed excavation shape of the newly blasted development. Internal dilution (planned dilution) is primarily a function of the geometry of the orebody and the minimum mining width.

In operating underground mines, an additional type of dilution can occur. This dilution occurs when blasting of new cut and fill development takes place adjacent to a previously excavated development containing backfill material. In these situations, a portion of the backfilled volume can become entrained with the newly blasted material. The grades of the backfill material are typically far below the breakeven cut-off grade or value, and this material contributes to the total dilution of the newly blasted material. Furthermore, the backfill can have very different chemical characteristics to the mineralized material and its inclusion in the process plant feed can have serious adverse consequences for the process plant. This dilution is referred to as secondary dilution.

The dilution percentage is defined as tonnes of dilution material (W) divided by tonnes of mineralized material (O) (Dilution % = $W/O \times 100$).

12.3.1.1 Development Overbreak

Due to the challenging ground conditions in KHM, the expected overbreak for capital lateral development is 10%. This is comparable to what was achieved during the excavation of the Flame and Moth and Bermingham exploration declines.

12.3.1.2 MCF Dilution

The minimum mining width for the MCF method in all deposits is 3.5 m. The MCF development contains internal dilution within the proposed mining shape due to the narrow vein width. No external dilution has been allowed due to the highly selective nature of the chosen mining method.

The Mining Plus mining QP is of the opinion that the exclusion of unplanned dilution in the MCF production shapes is potentially optimistic. There is potential for unplanned dilution to be introduced through small scale variations in the vein location, floor or wall backfill material, overbreak, and re-handle dilution. Mining Plus recommends that a reconciliation program be established for the current production areas in Bermingham to better understand the potential impact of unplanned dilution and apply those findings to future Mineral Reserve updates.

12.4 RECOVERY

Mining recovery is the difference between the planned amount of ore and the actual amount of ore that is mucked and sent to the mill.

Due to the high-grade nature of the mineralization, all efforts will be made to ensure that recovery is maximized. A mining recovery of 100% has been applied to all planned production blocks due to the highly selective nature of the mining method. The Mining Plus mining QP considers this assumption to be reasonable and recommends close survey monitoring of the performance of the production areas to ensure that production as-builts are able to fully recover the Mineral Reserve when compared to design.

12.5 RISK FACTORS THAT COULD MATERIALLY AFFECT THE MINERAL RESERVE ESTIMATE

In the opinion of the Mining Plus mining QP, the Mineral Reserves are subject to the type of risks that are common to underground polymetallic narrow vein mining operations and may be materially affected by the following risk factors:

- Changes in realized metal prices from what was assumed.
- Changes to the mining costs, processing and G&A costs used to calculate the cut-off grade.
- Changes in local interpretation of mineralization geometry or modelled continuity of mineralized zones.
- Changes to geotechnical or hydrogeological design assumptions resulting in schedule delays, increased dilution, or reduced recoveries.
- Changes to mining and metallurgical recoveries.
- Changes in the long-term assumptions relating to concentrate payability, marketability and penalty terms.
- Changes in the mining development or geotechnical conditions resulting in additional unplanned dilution.
- Changes to the current mining method where certain zones or lenses permit.
- Assumptions as to the continued ability to access site, retain mineral tenure, obtain required environmental, mining, and other regulatory permits, and maintain a social license to operate with relevant stakeholders.

13. MINING METHODS

The Keno Hill Mine (KHM) contains five separate deposits: Bellekeno, Lucky Queen, Flame and Moth, Onek, and Bermingham. The location of the deposits is shown in Figure 13-1; the mill, administration, and shop complexes are located near the Flame and Moth Deposit.

All deposits are characterized by high grades, narrow vein widths, and challenging ground conditions. Historical mining methods used in Keno Hill have included cut and fill, small-scale long-hole stoping, shrinkage stoping, and square set stoping.

This section focuses on three deposits: Lucky Queen, Flame and Moth, and Bermingham. Lucky Queen is in the advanced exploration stage and the Mineral Reserve is included in the Life of Mine Plan (LOM). Flame and Moth, and Bermingham are currently mined by mechanized underground mining methods of cut and fill (MCF) with cemented rock fill (CRF) and unconsolidated rock fill (URF) as required.

The operations at Bellekeno deposit were suspended in 2021 and is not currently planned to be reopened without further study.

Onek is a historic mine with remaining Mineral Resources but is not currently planned to be reopened without further study.

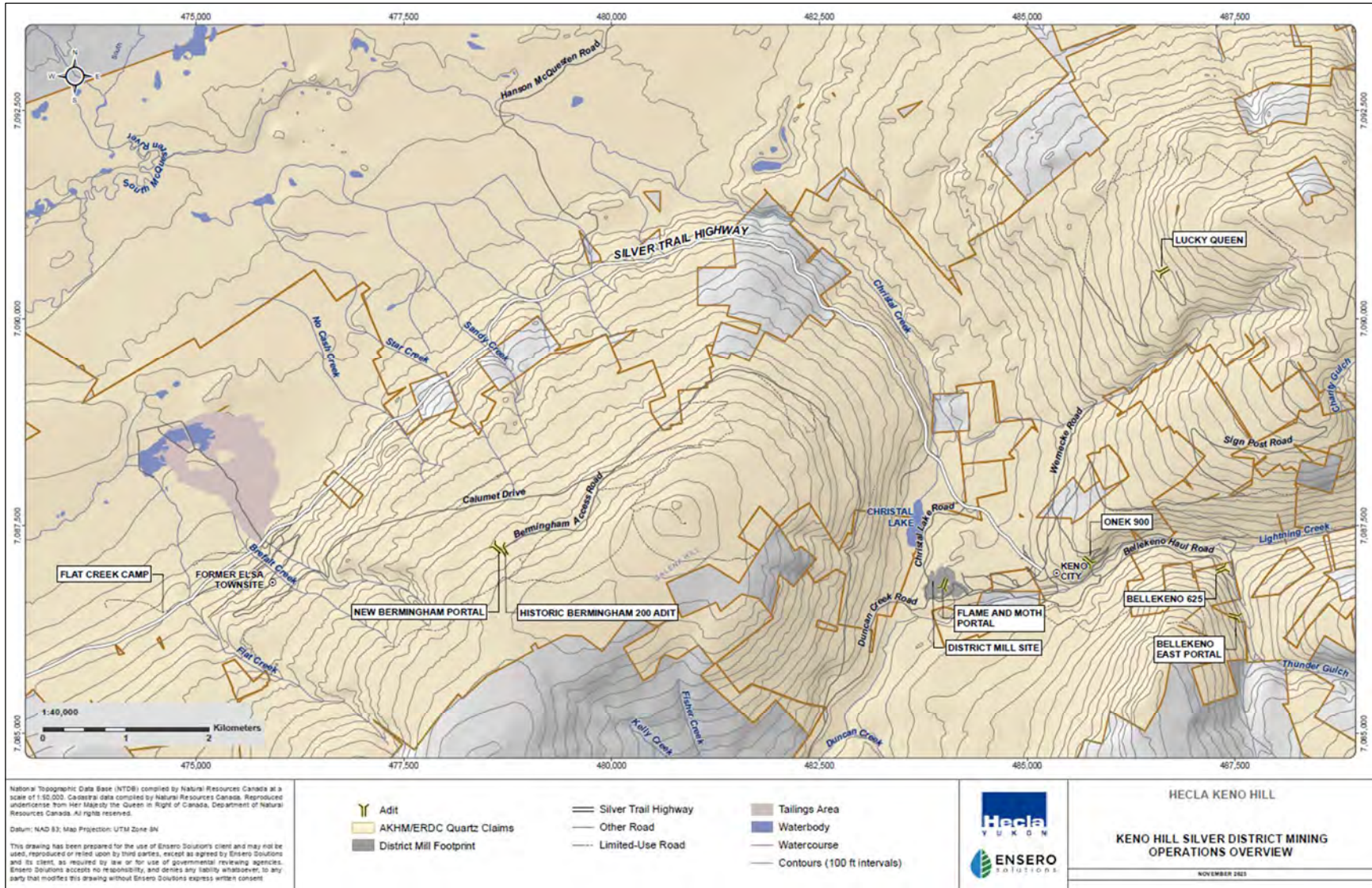

Figure 13-1 – Keno Hill Mine Location.

13.1 GEOTECHNICAL AND HYDROLOGICAL CONSIDERATIONS

Numerous geotechnical studies have been carried out on the KHM most recently by Jacobs Engineering (Jacobs, 2019).

13.1.1 GEOTECHNICAL DATABASE

Geotechnical data for this study was only available for the Flame and Moth and Bermingham deposits. Based on discussions with Hecla personnel, it is reasonable to assume that ground conditions previously encountered at the Bellekeno deposit will be comparable with those at the Lucky Queen. Therefore, operational experience gained during previous production mining at the Bellekeno deposit will be used to guide (but not directly influence) the development of geotechnical mine design parameters at the Lucky Queen deposit. However, prior to the execution stage, the geotechnical conditions of the Lucky Queen will need to be verified.

13.1.2 GEOTECHNICAL DOMAINS

To understand the ground conditions at the KHM, geotechnical domains were created for the Bermingham and Flame and Moth deposits. Preliminary geotechnical parameters were assessed using major lithology types as identified by Hecla geology personnel. The geotechnical domains are outlined below on which ground support designs have been based:

- Domain 1: Quartzite (waste development).
- Domain 2: Schist (waste development).
- Domain 3: Faults (waste and production development).
- Domain 4: Mineralization (production development).

13.1.3 STRUCTURAL CHARACTERIZATION

The Flame and Moth deposit is divided into the Lightning and Christal mining areas, which are separated by the Mill Fault. The Mill Fault offsets Christal in a southeast direction by approximately 120 meters relative to the Lightning mining area as shown in Figure 13-2.

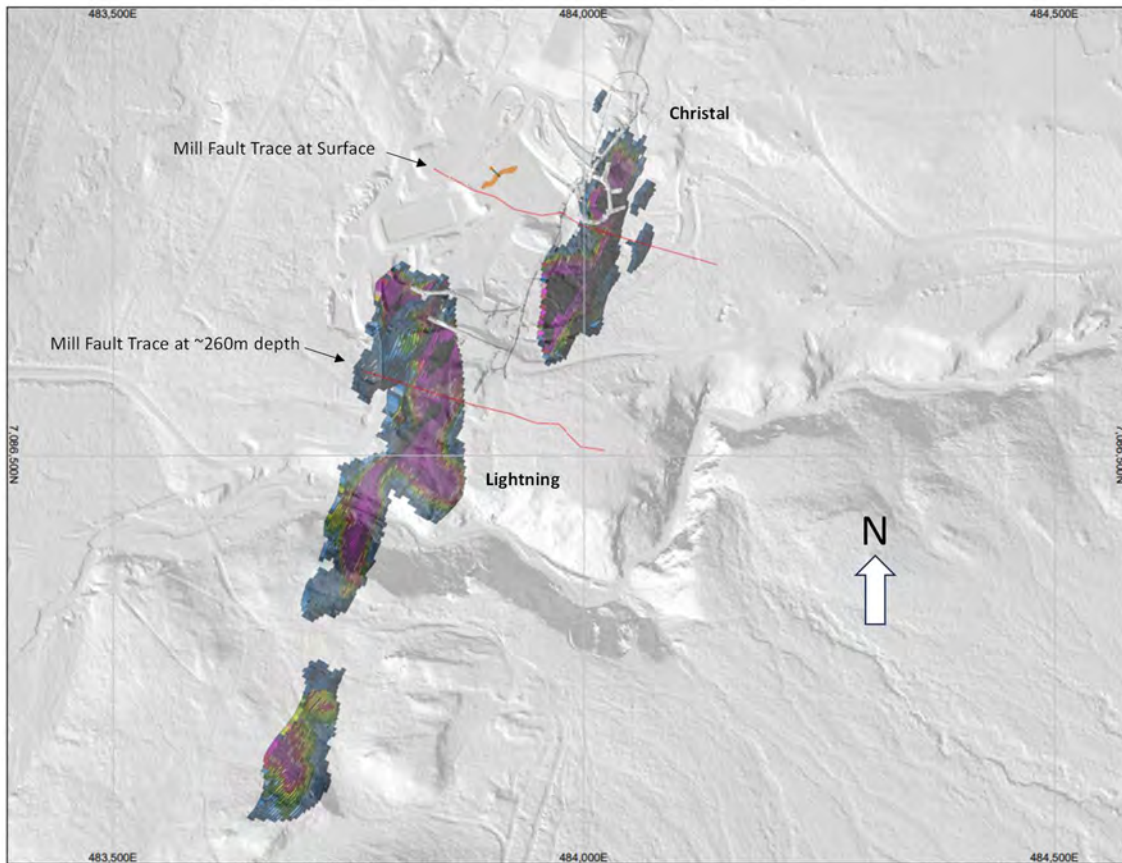

Figure 13-2 – Plan View of Flame and Moth Showing Fault Offset of Christal Relative to Lightning Mining Area.

The Birmingham deposit hosts five major faults as summarized in Table 13-1. Figure 13-3 shows a three-dimensional representation of the major faults relative to the Birmingham mine plan. The NE zone is located underneath the Ruby Fault while the Bear zone and Artic zone are located between the Ruby Fault and Cross Fault and Cross Fault and Mastiff Fault respectively. The Super Fault intercepts the upper part of the Artic zone but does not intercept the ore veins within the Birmingham deposit.

Table 13-1 – Average Trend of Major Faults in the Birmingham Deposit.

Fault ID	Strike	Dip (°)
Mastiff Fault	131	-52
Ruby B Fault	124	-68
Hanging Wall Fault	0	-60
Super Fault	133	-25
Cross Fault	114	-62

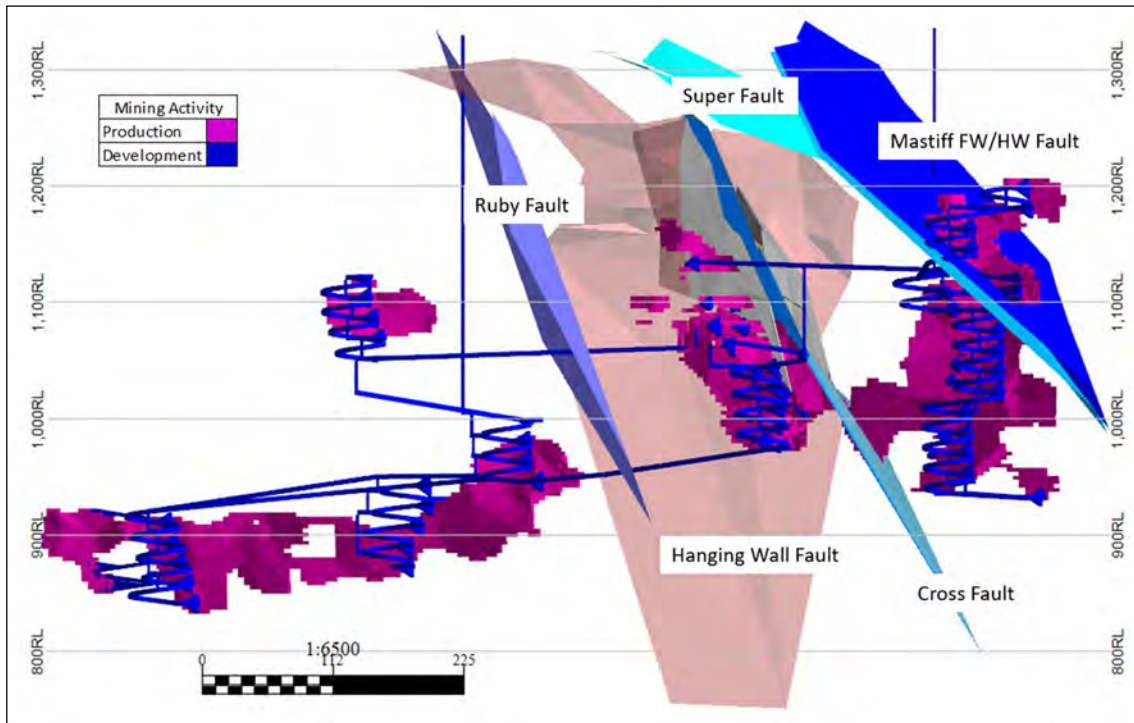

Figure 13-3 – Longitudinal Section View (Looking South-East) of Bermingham.

13.1.4 ROCK QUALITY DESIGNATION (RQD)

A first-pass assessment of the rock mass in geotechnical domains was completed by considering the Rock Quality Designation (RQD) (after Deere, 1964). RQD is a fundamental input into several rock mass characterization schemes and is generally regarded as a reliable, basic indicator of ground conditions. The RQD is calculated as the ratio of the sum of the lengths of all core sticks greater than 10 cm in length, to the total length of the drill core run, expressed as a percentage.

A summary of RQD values for the Bermingham and Flame and Moth deposits and geotechnical domains is presented in Table 13-2. The descriptive statistics for each domain are described as 'Poor', except for the Fault domain of the Bermingham deposit ('Very Poor') and the Mineralization Domain of the Flame and Moth deposit ('Fair').

Table 13-2 – Summary of RQD Values for Flame and Moth and Bermingham Deposits by Geotechnical Domain.

Deposit	Descriptive Statistics	Domain 1	Domain 2	Domain 3	Domain 4
Flame and Moth	Mean	49%	43%	27%	51%
	Median	49%	42%	24%	57%
	Std. Deviation	25%	25%	22%	26%
	Coefficient of Variation	51%	58%	80%	51%
Bermingham	Mean	36%	30%	22%	35%
	Median	33%	25%	17%	34%
	Std. Deviation	25%	23%	21%	22%
	Coefficient of Variation	69%	79%	94%	64%

It should be noted that over 90% of boreholes in the geotechnical database were drilled using conventional, double-tube drilling equipment. This approach may lead to excessive disturbance of the core ('mechanical' or handling breaks) which can be difficult to distinguish from naturally occurring joints when logging RQD. This can typically result in artificially low RQD values.

Based on a review of in-situ rock mass exposed in underground excavations, an under-representation of RQD values in double-tube core drilling was likely to be the case at the KHM. As such, the summary values in Table 13-2 may be 'worst case', however it is problematic to estimate likely upper bound values with confidence. It is recommended that all future geotechnical holes are drilled using the triple-tube system.

13.1.5 NGI Q AND GSI ROCK MASS CLASSIFICATION VALUES

Rock mass classification was conducted using the Norwegian Geotechnical Institute's tunneling quality index (the Q-system), as proposed by Barton et al. (1974), where Q is obtained from the following relationship: RQD (as described above), Joint Set Number (J_n), Joint Roughness (J_r), Joint Alteration (J_a), Joint Water Factor (J_w), and the Stress Reduction Factor (SRF):

Equation 1: Q Equation Barton et al. (1974).

$$Q = \frac{RQD}{J_n} \cdot \frac{J_r}{J_a} \cdot \frac{J_w}{SRF} \quad (1)$$

Q values have been estimated using the methods outlined by Barton and Grimstad (1994), whereby:

- Use representative Q input values for each geotechnical domain; and
- Where logged recorded RQD values are $\leq 10\%$ (including 0%), use a nominal value of 10% to evaluate Q.

To better understand the statistical variability and character within each data set, basic descriptive statistics and histograms were generated for each input value, within each geotechnical domain for the Bermingham and Flame and Moth deposits. This information was used to identify representative values for each Q input value. In the case of J_w and SRF, site experience, assumed far-field stress conditions, and a typical depth of mining were applied, along with engineering judgment to derive input values. The NGI Q estimates for the Bermingham and Flame and Moth deposits and geotechnical domains are presented in Table 13-3. Table 13-4 provides a comparative summary of the Geological Strength Index (GSI) for the Keno Hill deposits with extrapolated NGI-Q values shown.

Table 13-3 – Summary of NGI Q values for Flame and Moth and Bermingham Deposits by Geotechnical Domain.

Input Parameter	Quartzite (Domain 1)		Schist (Domain 2)		Faults (Domain 3)		Ore Vein (Domain 4)	
	Mean (drill core)	40.0	Mean (drill core)	25.0	Mean (drill core)	20.0	Mean (drill core)	50.0
Jn	2 Joint sets	4.0	2 Joint sets	4.0	2 Joint sets	4.0	2 Joint sets	4.0
Jr	Undulating, smooth	2.0	Undulating, smooth	2.0	Undulating, smooth	2.0	Undulating, smooth	2.0
Ja	Non-softening, fine	3.0	Non-softening, fine	3.0	Non-softening, medium	3.0	Non-softening, medium	3.0
Jw	Dry (minor inflow)	1.0	Wet (drips/rain)	0.7	Wet (drips/rain)	0.7	Dry (minor inflow)	1.0
SRF	Low stress	2.5	Low stress	2.5	Low stress	2.5	Low stress	2.5
Q (Avg)	2.7		1.3		0.9		3.3	

Table 13-4 – General Summary of Rock Mass Classification for Keno Hill.

Rock Mass Quality	Domain	GSI			Q Value Extrapolation
		Structure	Surface	Value	
Fair to Good	Domain 1 - Quartzite	Blocky Very Blocky	Rough Smooth	45 - 60	2.0 - 6.0
Poor to Fair	Domain 2 - Schist	Very Blocky Seamy	Smooth Weathered	30 - 45	0.3 - 2.0
Extremely Poor to Poor	Domain 3 - Faults	Disintegrated Foliated	Slickensided	20 - 30	0.05 - 0.3
Poor to Fair	Domain 4 - Mineralization	Very Blocky Seamy	Smooth Weathered	30 - 45	0.3 - 2.0

13.1.6 GROUND SUPPORT DESIGN

Ground support designs for Flame and Moth and Bermingham have been developed by Hecla personnel according to the following primary development types shown below in Table 13-5.

Table 13-5 – Development Excavation Dimensions by Type and Stand-up Time.

Opening Development	Stand-up Time	Dimension (W x H, m)
Main Ramp (MAR)	Permanent	4.5 x 4.5 (arched)
Level Access Drift (LVL)	Less than three years	4.5 x 4.5 (arched)
Cut and Fill (CF) Production Drift	Less than one year	3.5 ~ 7.0 x 3.5 (flat back with rounded corners)
Remuck (RMK)	Less than three years	5.0 x 5.5 (flat back with rounded corners)
Take Down Back (TDB) retreat Drift underneath Backfill	N/A	5.5 x 6.0
Raise	Permanent	2.8 x 2.8 or D = 3.0

Ground support classes have been established according to the accessed RQD of the rock mass for the development. Details for each ground support class are summarized below:

- Class I – Regular ground with RQD > 40%.
- Class II – Poor to fair ground with 25% < RQD < 40%.
- Class III – Very poor ground with RQD < 25%.

A ground control management plan has been developed for each deposit that governs the ground support methodology. A minimum ground support standard using 1.8 m to 2.4 m long rock bolts for the back and walls has been recommended to prevent possible wedge failure or unconsolidated back and wall sloughing caused by blasting damage. Further refinement to the ground support standard is anticipated as data from underground development is collected and analyzed. Where abnormal ground conditions are encountered, the ground support protocols are to be reviewed for effectiveness and additional support recommendations as determined by a Geotechnical Engineer or designate.

Table 13-6 provides a summary of the Flame and Moth and Bermingham ground support standards. All ground support patterns employ 4" (0.10 m) square, 6-gauge welded wire mesh with the exception of the cut and fill drifts which employ 3" (0.07 m) square, 6-gauge welded wire mesh.

Table 13-6 – Flame and Moth and Bermingham Ground Support Standard (Hecla, 2023d and Hecla, 2022c)

Type	Ground Condition	Ground Support Standards (Bolt Spacing)	
Decline Ramp (permanent openings)			
MAR – I	Regular Ground (40 < RQD)	Back	2.4 m Coated Swellex (1.2 m x 1.2 m)
		Wall	2.4 m Coated Swellex (1.2 m x 1.2 m), 2.0 m from sill
MAR – II	Poor to Fair (25 < RQD < 40)	Back	2.4 m Coated Swellex (1.2 m x 1.2 m), Spiling/Shotcrete as required
		Wall	2.4 m Coated Swellex (1.2 m x 1.2 m) 2.0 m from sill, Spiling/Shotcrete as required
MAR – III	Very Poor Ground (RQD < 25)	Back	2.4 m Coated Swellex (1.2 m x 1.2 m), Spiling as required
		Wall	2.4 m Coated Swellex (1.2 m x 1.2 m) 1.5m from sill, Spiling as required
		Shotcrete	Plain, minimum 3.0" thickness with 1" pre-coat

Type	Ground Condition	Ground Support Standards (Bolt Spacing)	
Level Access Drift (opening less than 3 years)			
LVL – I	Regular Ground (40 < RQD)	Back	2.4 m Coated Swellex (1.2 m x 1.2 m)
		Wall	2.4 m Coated Swellex (1.2 m x 1.2 m), 2.0 m from sill
LVL – II	Poor Ground (25 < RQD < 40)	Back	2.4 m Coated Swellex (1.2 m x 1.2 m), Spiling/ Shotcrete as required
		Wall	2.4 m Coated Swellex (1.2 m x 1.2 m) 2.0 m from sill, Spiling/Shotcrete as required
	Very Poor Ground (RQD < 25)	Back	2.4 m Coated Swellex (1.2 m x 1.2 m), Spiling/Shotcrete as required
		Wall	2.4 m Coated Swellex (1.2 m x 1.2 m) 1.5m from sill, Spiling/Shotcrete as required
		Shotcrete	Plain, minimum 3.0" thickness with 1" pre-coat
		Spiling	Face (3.0 m long with 1m tail pinned with strapping to back)
Cut and Fill Drift (opening less than 1 year)			
CF-I	Regular Ground (40 < RQD)	Back	1.8 m Swellex (1.2 m x 1.2 m Dice)
		Wall	1.8 m Swellex (1.2 m x 1.2 m Dice), 1.5m from sill
CF-II	Poor Ground (25 < RQD < 40)	Back	1.8 m Swellex (1.2 m x 1.2 m Dice)
		Wall	1.8 m Swellex (1.2 m x 1.2 m Dice), 1.5m from sill
CF-III	Very Poor Ground (RQD < 25)	Back	1.8 m Swellex (0.8m x 0.8m), 2" SC, Spilling as required
		Wall	1.8 m Swellex (0.8m x 0.8m), 2" SC, Spilling as required
		Shotcrete	Plain, minimum 3.0" thickness with 1" pre-coat
		Spiling	Face (3.0 m long with 1m tail pinned with strapping to back)
Wide Production Retreat Drift (3.0 .5 m ~ 7.0 m)			
CFW – I	Regular Ground (40 < RQD)	Back	CF-I + 3.0 .6 m Superswellex (2.0 m x 2.0 m)
		Wall	CF- I
CFW – II	Poor Ground (25 < RQD < 40)	Back	CF-II + 3.0 .6 m Superswellex (1.8 m x 1.8 m), 2" SC as required
		Wall	CF-II
Remuck			
RMK – I	Regular Ground (40 < RQD)	Back	2.4 m Coated Swellex (1.2 m x 1.2 m)
		Wall	2.4 m Coated Swellex (1.2 m x 1.2 m) 2.0 m from sill, Shotcrete as required
		Shotcrete	Plain, minimum 3.0 " thickness with 1" pre-coat
RMK - II	Poor Ground (25 < RQD < 40)	Back	2.4 m Coated Swellex (1.2 m x 1.2 m), Spiling/Shotcrete as required
		Wall	2.4 m Coated Swellex (1.2 m x 1.2 m) 2.0 m from sill, Spiling/Shotcrete as required
		Shotcrete	Plain, minimum 3.0" thickness with 1" pre-coat
RMK - III	Very Poor Ground (RQD < 25)	Back	2.4 m Coated Swellex (1.2 m x 1.2 m), Spiling/Shotcrete as required
		Wall	2.4 m Coated Swellex (1.2 m x 1.2 m) 2.0 m from sill, Spiling/Shotcrete as required
		Shotcrete	Plain, minimum 3.0" thickness with 1" pre-coat
		Spiling	Face (3.0 m long with 1m tail pinned with strapping to back)
Raise			
SR – I CR – I	Regular Ground (40 < RQD)	Face	1.5 m Swellex or Rebar (1.2 m x 1.2 m)
		Wall	1.5 m Swellex or Rebar (1.2 m x 1.2 m)
SR – II CR – II	Poor Ground (25 < RQD < 40)	Face	1.5 m Swellex or Rebar (0.8m x 0.8m), 2" SC as required
		Wall	1.5 m Swellex or Rebar (0.8m x 0.8m), 2" SC as required

Type	Ground Condition	Ground Support Standards (Bolt Spacing)	
Intersection			
IS-1	Regular Ground (40 < RQD)	Back	MAR/LVL-1 + 3.0 .6 m Connectable (2.0 m x 2.0 m)
		Pillar	3.0 rows of strap with 2.4 m Swellex

Intersections are recognized as posing a higher risk for ground instability and the site Ground Control Management Plans (GCMPs) provide the following guidance to minimize this risk:

- 4-way intersections should be avoided as much as possible.
- Intersections in very poor ground must be avoided and/or relocated.
- Over-excavation should be minimized.

13.1.7 PILLAR SIZING

Mechanized cut and fill mining at Keno Hill requires rib pillars to mine parallel veins and sill pillars between sublevels. Rib pillars for adjacent mining are nominally sized at 3m. Sill pillars between sublevels are also sized at no smaller than 3 m and nominally targeted to be 4m high. Previous evaluations of pillar sizing were done using the formula developed by Potvin et al. (1989), shown below:

Equation 2: Pillar Strength by Potvin et al. (1974).

$$\text{Pillar Strength (MPa)} = 0.42 * \text{UCS} * \text{W/H} \quad (2)$$

13.2 HYDROLOGICAL CONSIDERATIONS

The Lucky Queen and Bermingham mining zones are located above the valley floor. Consequently, this tends to limit the occurrence and effect of adverse hydrogeological conditions. However, the Flame and Moth deposit is located on a valley floor such that there is a possibility of higher water inflow to the workings. Preliminary investigations suggest that groundwater may be structurally compartmentalized in the deposit-scale Mill Fault. Additional hydrogeological studies are underway in 2024 that are expected to further improve the hydrogeological understanding and modelling at Bermingham.

13.3 MINE DESIGN

13.3.1 MINING METHOD

Keno Hill ore is mined with a mechanized cut and fill method (MCF). Where the ore width is wider than can be safely extracted in one cut, the ore will be mined in adjacent drifts. Lenses are predominantly mined in a bottom-up sequence and filled with cemented rock fill (CRF) with a 3%-8% binder content. CRF

is used to introduce temporary sill levels or to fill initial drifts when multiple adjacent drifts are required. Temporary sill levels form a sequence interrupting pillar which allows for multiple mining fronts to be active on one lens at a time. The remainder of the lifts will be backfilled with URF.

This mining method was chosen due to the narrow steeply dipping nature of the orebodies and to maximize safety and productivity. The various deposits require the use of mining methods that can adequately support the vein and that are flexible and selective while minimizing the direct mining costs.

The main factors driving the mining method selection process are:

- Ground conditions in the vein and along the vein contacts range from good to very poor.
- Ground conditions can vary substantially over short distances (five meters).
- Vein continuity is good; however, the veins geometry varies greatly between deposits.
- Metal content and distribution vary significantly both between deposits and the mining zones within each deposit.
- The footwall is often characterized by competent quartzite but can be weak in some areas.
- The hanging wall varies from competent quartzite to weak layers of quartz breccia with clay-filled shear bands, graphitic schists, or sericite schists.
- Geological contacts at the hanging wall and footwall can often be visually identified but can be faulted or fractured contacts with gouge and breccias.
- Mineralization contacts are less clearly defined and are based on a combination of structure, vein mineralogy, and metal grades.
- Vein systems can be locally water-bearing and require time to drain when they are first crosscut by development.
- Vein depths are shallow with a low-stress regime, high-stress issues are not a factor in mine planning, but lack of clamping forces contributes to the poor ground conditions.

In MCF method, an attack ramp is developed from the main ramp at a gradient of -15%. Upon reaching the orebody, an intersection is developed, and a lift is developed in both directions along strike, following the geological contact of the orebody. At the end of the lens, the void is backfilled using either with a Load Haul Dump (LHD) machine. The LHD utilizes a rammer-jammer plate (a dozer plate modified to be attached to an LHD to push waste tight to the back) to ensure that the backfill is placed tight to the back of the drift.

Once the level has been completely backfilled, the next lift above the previously mined lift is accessed by slashing down the back of the attack ramp and working off the muck pile/horizon. Figure 13-4 illustrates the sequence of activities with MCF mining.

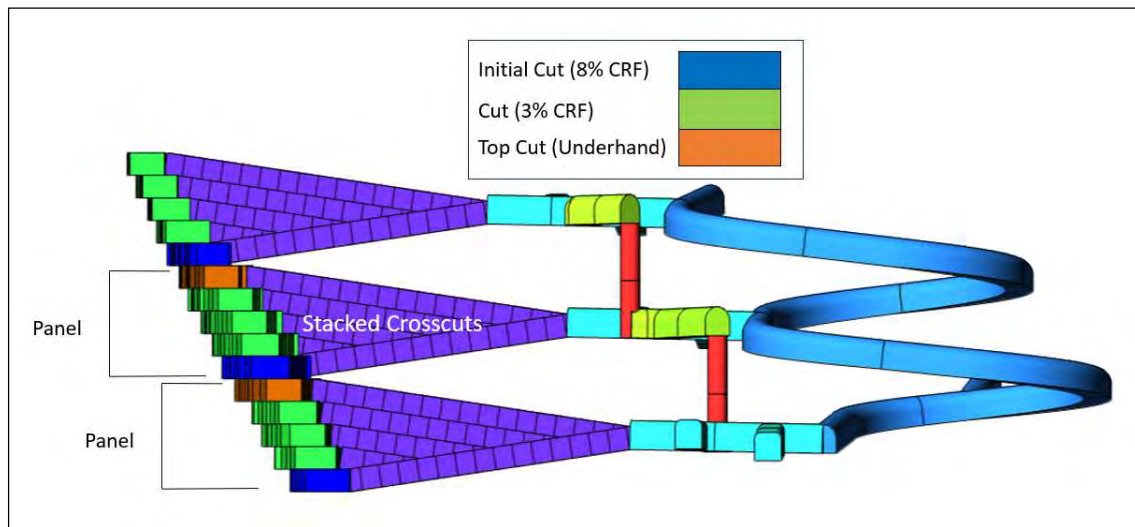

Figure 13-4 – Mechanized Cut and Fill Mining Method Layout.

MCF drift sizes for Flame and Moth and Birmingham deposits are on average 3.5 m H x 3.5 m W. MCF drift sizes for Lucky Queen deposit are on average 3.5 m H x 3.5 m W. For areas wider than development equipment capable of mining or supporting a second parallel drift will be mined beside the backfilled drift to fully extract the orebody width prior to accessing the lift above. In this situation, the first drift will be completely backfilled with cemented rock fill to ensure a stable wall to allow adjacent mining activity.

For the Birmingham, and Flame and Moth deposits, the lifts are sequenced bottom-up within each panel; however, to maximize productivity the panels are mined as access allows. As such, the final lift in a panel located under an adjacent panel will be mined underhand with the back being the 8% CRF used to fill the initial cut of the panel above.

13.3.2 MINE DESIGNS

13.3.2.1 Lucky Queen

The Lucky Queen is located approximately 10 km from the mill and has previously been the site of underground production by a previous operator. Approximately one km of old workings has been rehabilitated from the portal. The access drift is 3.0 m W x 3.6 m H and production drifts will be sized at a minimum of 3.5 m W x 3.5 m H. These drifts are too small for some of the production and development mining fleets used at the other mines. The Lucky Queen deposit is planned to be mined at the end of the LOM plan using contractor mining.

Figure 13-5 shows a south-looking view of the existing and planned workings.

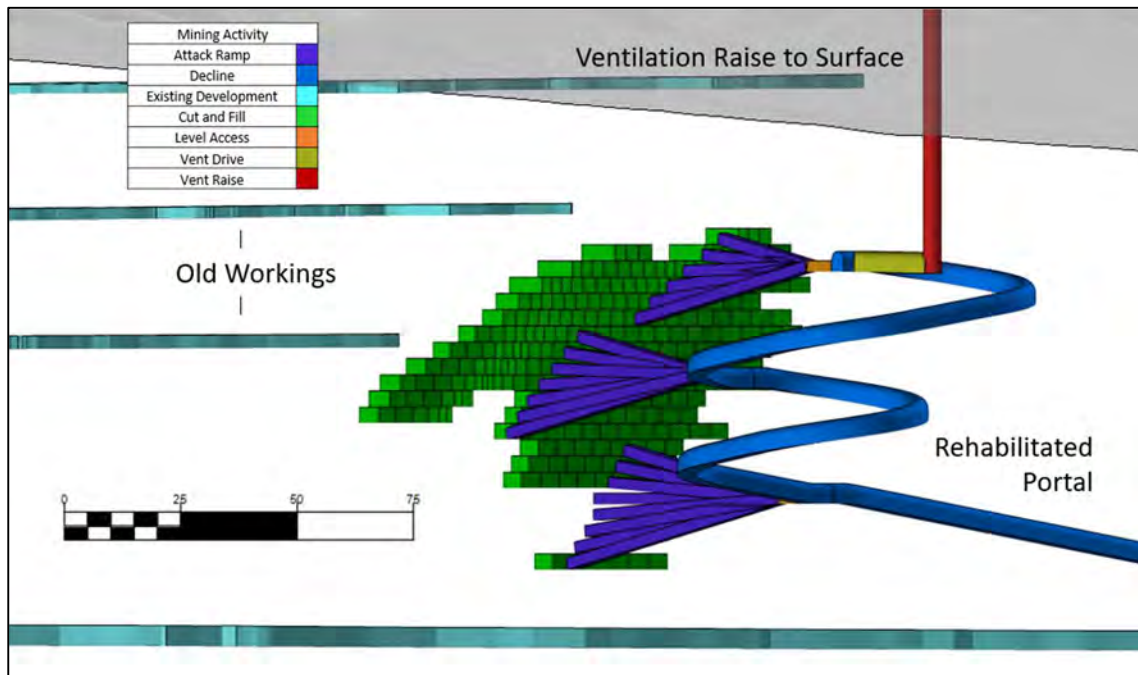

Figure 13-5 – Lucky Queen Isometric View (Looking South).

Table 13-7 shows the annual production schedule for the Lucky Queen.

Table 13-7 – Lucky Queen Production Quantities.

Lucky Queen	Total	2024	2025	2026	2027	2028	2029	2030	2031	2032	2033	2034
Total Tonnes	152,427										39,862	112,565
Ore Tonnes	103,365										18,000	85,365
Waste Tonnes	49,062										21,862	27,200
Backfill Tonnes	93,029										16,200	76,829
Ag (g/t)	948										948	948
Au (g/t)	0.09										0.09	0.09
Pb (%)	2.03										2.03	2.03
Zn (%)	1.06										1.06	1.06
Ag (Oz)	3,151,240										548,758	2,602,483
Au (Oz)	305										53	252
Pb (lbs)	4,631,016										806,446	3,824,570
Zn (lb)	2,417,984										421,068	1,996,916
Development (m)	1,554										687	866

Notes:

1. Development is lateral and vertical meters.
2. Ore tonnes are all Probable Mineral Reserves as shown in Section 12 of this report.
3. Rounding as required by reporting guidelines may result in apparent summation differences between tonnes, grade and contained metal content.
4. Tonnages are diluted and recovered.
5. Tonnage and grade measurements are in metric units. Contained silver ounces are reported as a troy ounce.

13.3.2.2 Flame and Moth

Flame and Moth is located adjacent to the existing mill and administration facilities. Access to the deposit is through an already-developed portal and a 460-meter-long ramp. Ore from the Flame and Moth is sourced from the Lightning and the Christal zones, which contain approximately 64% and 36% of total ore tonnes, respectively. Development in the Flame and Moth is sized 4.2 m W x 4.2 m H for the ramp and 3.5 m W x 3.5 m H for the operating development and cut and fill stopes.

Emergency egress and ventilation for the Flame and Moth are provided through a vent raise driven to the surface. Figure 13-6 shows a long section of the existing and planned workings.

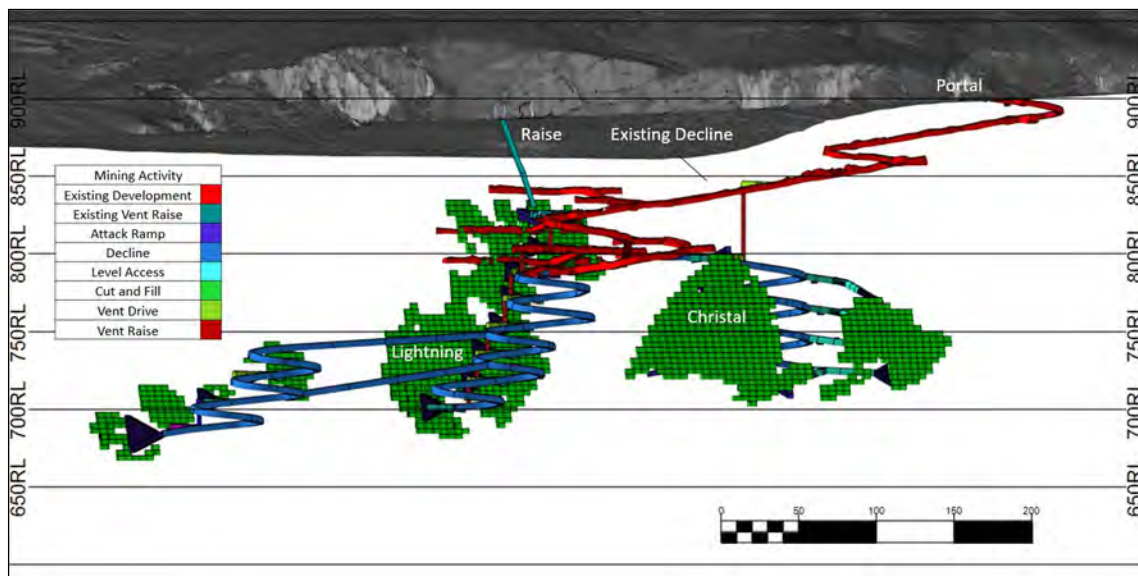

Figure 13-6 – Flame and Moth (Looking North-West).

Table 13-8 shows the annual production schedule for the Flame and Moth.

Table 13-8 – Flame and Moth Production Quantities.

Flame and Moth	Total	2024	2025	2026	2027	2028	2029	2030	2031	2032	2033	2034
Total Tonnes	771,785				127,499	124,124	125,087	118,862	115,923	113,977	46,312	
Ore Tonnes	455,243				56,485	73,244	73,244	72,657	65,784	71,477	42,352	
Waste Tonnes	330,990			14,448	71,014	50,880	51,842	46,205	50,140	42,500	3,960	
Backfill Tonnes	415,438				38,237	39,055	59,340	66,900	64,226	68,889	65,852	12,940
Ag (g/t)	764				704	745	832	844	783	663	765	
Au (g/t)	0.48				0.30	0.46	0.50	0.52	0.52	0.52	0.48	
Pb (%)	2.86				2.30	3.37	3.75	3.61	2.54	1.46	2.77	
Zn (%)	5.83				6.89	6.06	6.60	6.25	5.74	4.33	4.62	
Ag (Oz)	11,184,379				1,278,194	1,753,811	1,958,839	1,972,504	1,655,844	1,523,061	1,042,126	
Au (Oz)	6,958				542	1,077	1,181	1,213	1,097	1,195	653	
Pb (lbs)	28,720,473				2,866,083	5,448,197	6,058,163	5,778,154	3,679,267	2,307,671	2,582,938	
Zn (lb)	58,499,658				8,585,504	9,785,034	10,654,467	10,008,659	8,321,434	6,827,366	4,317,195	
Development (m)	8,126			293	1,727	1,228	1,265	1,073	1,224	1,197	120	

Notes:

1. Development is lateral and vertical meters.
2. Ore tonnes are all Probable Mineral Reserves as shown in Section 12 of this report.
3. Rounding as required by reporting guidelines may result in apparent summation differences between tonnes, grade and contained metal content.
4. Tonnages are diluted and recovered.
5. Tonnage and grade measurements are in metric units. Contained silver ounces are reported as a troy ounce.

13.3.2.3 Bermingham

Bermingham deposit is located approximately 4 km from the mill underneath the historic Bermingham Pit. Access to the deposit is through the portal. Ore from the Bermingham is sourced from the Arctic, Bear, Etta, Northeast, and Bermingham Deep zones as shown in Figure 13-7. Development in the Bermingham is sized 4.2 m W x 4.2 m H for the ramp and an average of 3.5 m W by 3.5 m H for the operating development and MCF development. Emergency egress and ventilation are provided by a ventilation raise driven to the surface.

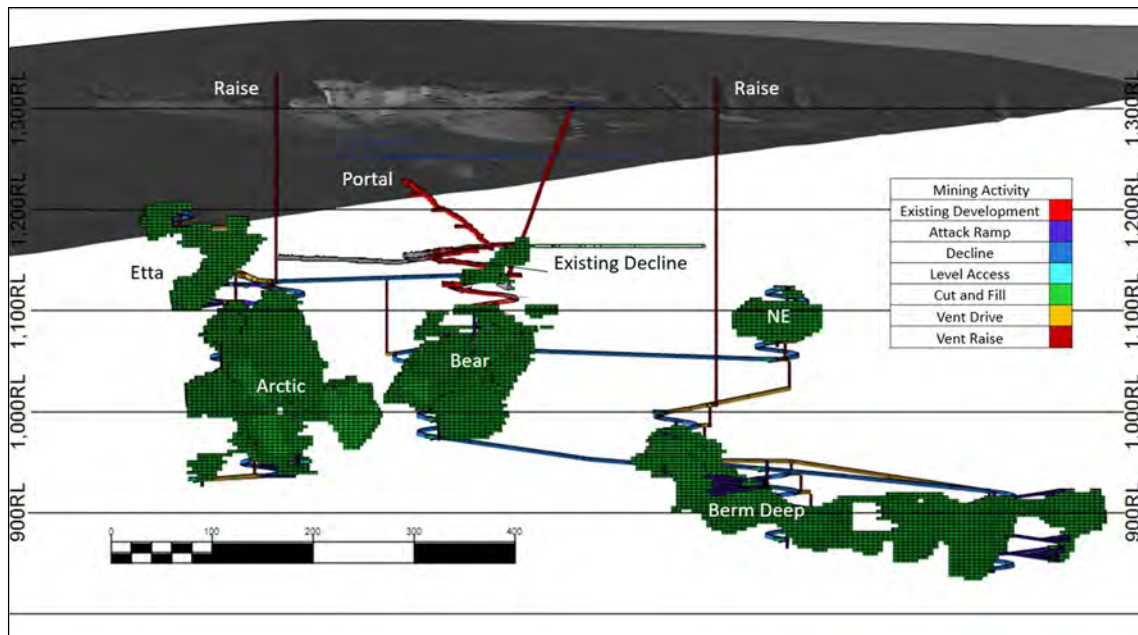

Figure 13-7 – Bermingham Isometric View (Looking Southeast).

Ore, waste and backfill are handled by 22-tonne capacity haulage trucks underground. Trucks are loaded at remuck bays on the ramp systems and hauled directly to the surface ore pad. From the surface ore pad, all ore is loaded on 30-tonne articulated trucks to be transported to the mill.

Surface handling and backfill of Bermingham waste rock is based on geochemical characterization and approved waste rock characterization and management as required by the Water Licence QZ18-044.

Table 13-9 shows the production quantities and table for the Bermingham.

Table 13-9 – Bermingham Production Quantities.

Bermingham	Total	2024	2025	2026	2027	2028	2029	2030	2031	2032	2033	2034
Total Tonnes	2,213,581	300,680	240,082	178,975	267,593	263,368	214,373	175,022	180,666	179,823	213,000	
Ore Tonnes	1,318,748	127,307	139,259	146,136	120,452	127,559	127,635	128,260	133,293	128,757	140,091	
Waste Tonnes	894,833	173,373	100,824	32,839	147,140	135,809	86,738	46,763	47,373	51,066	72,908	
Backfill Tonnes	1,303,633	91,542	149,323	162,242	95,065	108,115	106,088	135,187	147,296	140,847	166,308	1,620
Ag (g/t)	955	944	941	974	926	909	1,008	1,073	1,104	931	803	
Au (g/t)	0.14	0.10	0.11	0.13	0.12	0.15	0.18	0.20	0.19	0.15	0.12	
Pb (%)	2.80	2.11	2.05	2.00	2.18	3.52	2.96	3.33	4.17	3.39	2.92	
Zn (%)	1.50	1.34	1.58	1.99	1.51	1.59	1.46	1.62	1.27	1.23	1.44	
Ag (Oz)	40,732,395	3,863,236	4,215,044	4,575,038	3,587,951	3,727,827	4,136,539	4,424,784	4,730,605	3,853,141	3,618,230	
Au (Oz)	6,168	427	513	603	466	612	747	822	805	626	546	
Pb (lbs)	82,991,516	5,934,795	6,299,234	6,446,128	5,776,345	9,900,692	8,342,488	9,425,372	12,246,252	9,613,451	9,006,759	
Zn (lbs)	43,838,846	3,749,760	4,841,551	6,404,024	3,997,978	4,471,659	4,109,309	4,593,716	3,720,366	3,504,379	4,446,104	
Development (m)	22,825	4,219	2,730	996	3,351	3,302	2,248	1,300	1,254	1,340	2,084	

Notes:

1. Development is lateral and vertical meters.
2. Mill feed tonnes are all Probable Mineral Reserves as shown in Section 12 of this report.
3. Rounding as required by reporting guidelines may result in apparent summation differences between tonnes, grade and contained metal content.
4. Tonnages are diluted and recovered.
5. Tonnage and grade measurements are in metric units. Contained silver ounces are reported as a troy ounce.

13.4 BACKFILLING

Backfilling is cemented rock fill (CRF). All backfill material is hauled by the underground haul trucks and placed using LHDs. In areas where a tight seal between the backfill and the back is required, the LHD is equipped with a rammer-jammer plate to push the backfill tight to the back. CRF is mixed in the nearest remuck bay to the backfill area, which is driven at a slight negative grade (e.g., -2%). Cement is currently provided by a mobile cement batch plant and mixed with the waste rock by the LHD. Hecla is planning to build a surface backfill plant at Bermingham in 2024. The plant will be capable of supplying a cemented backfill product that blends waste rock and dewatered mill tailings. The cement content in the CRF ranges between 3% - 8%. The 8% binder CRF is limited to cuts which will form the back of an underhand stope — the initial cut of panels which are above others along the same vein. All other cut and fill excavations are planned to use uncemented waste rock (URF) or 3% binder CRF if there is an adjacent cut to be mined.

13.5 VENTILATION

A ventilation model was designed based on the mine plan for the Bermingham, Flame and Moth, and Lucky Queen deposits. Primary fans, auxiliary fans, and heating units are installed at Bermingham and Flame and Moth mines.

13.5.1 MINE AIR HEATING

Intake air is heated to a minimum of +2°C for all mines. This requires approximately 1.9 MW for Flame and Moth, 1.8 MW for Bermingham, and 1.0 MW for Lucky Queen in the coldest month of January. Direct-fire propane heaters are utilized for Flame and Moth and Bermingham mines. Once mining in Bermingham is completed, Lucky Queen will make use of the existing propane heater and fan inventory. Figure 13-8 displays the average temperature at the nearest weather station of Mayo, Yukon Territory, Canada.

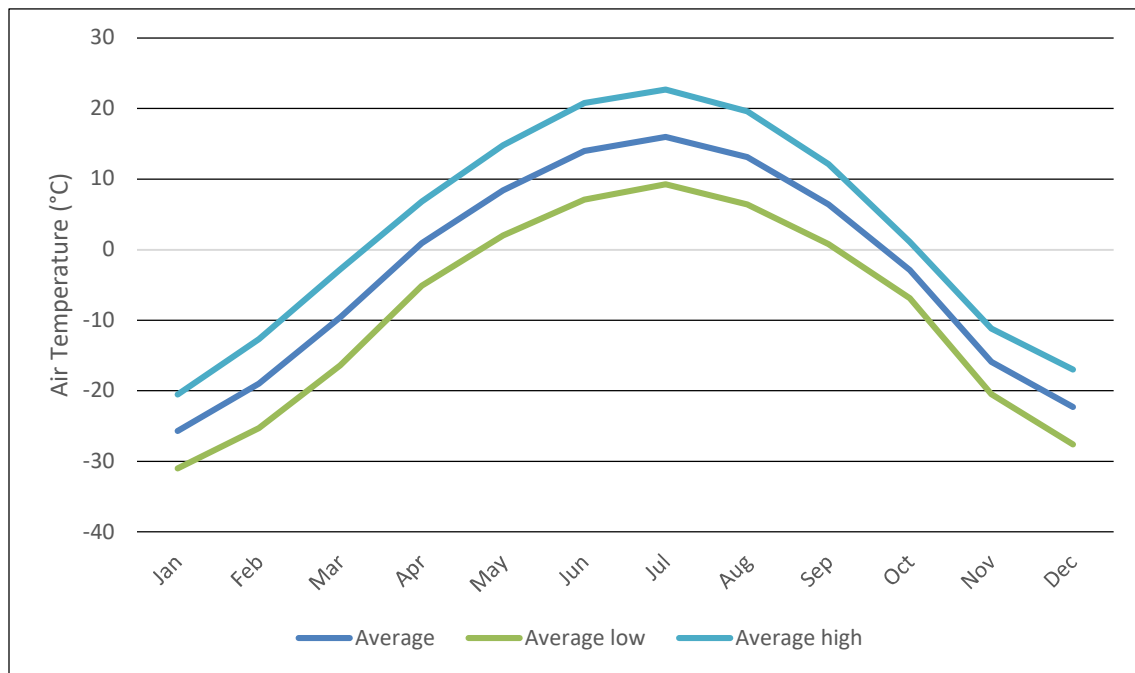

Figure 13-8 – Monthly Average Temperature for Mayo, Yukon Territory (Alexco, 2021b).

13.5.2 VENTILATION MODELLING

A ventilation model for each deposit was developed based on the proposed designs for the three mines using Ventsim® software. This was used to determine operability and estimate the required primary fan duties required at different stages of the mine life. Key modeling considerations include:

- Expected diesel equipment fleets for each mine are based on the mine plan.
- Utilization of availability for equipment is based on the mine plan.
- Associated friction factors and resistances are based on excavation methodology and accepted industry design values.
- A leakage allowance of 20% of total airflow demand.
- Early development work in both the main and ventilation declines will have fans located well outside each portal, a minimum of 50 m away, to limit the possibility of recirculation.
- Airways will maintain an air velocity of at least 0.5 m/s to remove contaminants and maintain an appropriate temperature in the mine.
- Working areas will be limited to an air velocity of 4 m/s and travel ways to a maximum of 6 m/s to maintain a safe and healthy environment.

13.5.2.1 Lucky Queen

The proposed layout for the Lucky Queen underground project will support a simple positive-pressure ventilation circuit. The primary fan located at the collar of a dedicated intake raise will cause air that has passed through a heating system to enter the mine. The air will then flow onto the ramp at the first available opportunity where it will be forced onto each level by an auxiliary fan, sweeping the face and returning to the ramp to repeat the process at the next working area. Ultimately, the air will be exhausted from the main portal. Figure 13-9 shows an isometric view of the ventilation circuit.

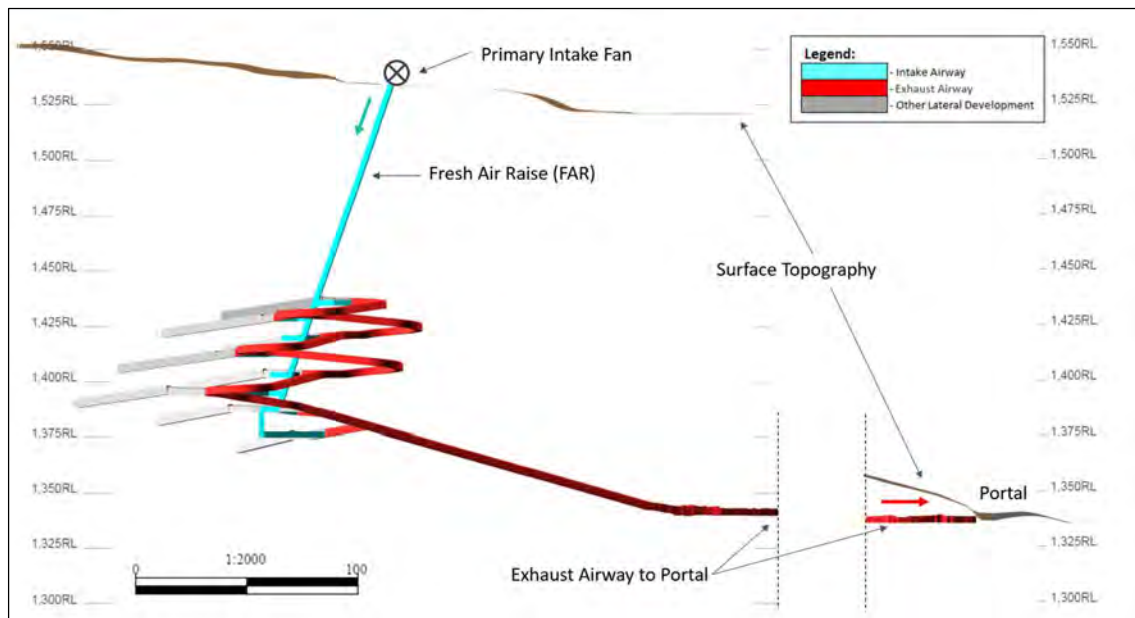

Figure 13-9 – Lucky Queen Primary Airflow Schematic (Alexco, 2021b).

Peak fan power for the Lucky Queen is estimated to be 34.0 kW. Peak airflow requirements reach 41 m³/s in year 10 of the project schedule and remain constant for the life of mine.

During initial development, low-friction twin ducts will be used to push the air the distance to the face. The number of concurrent activities underground will be restricted until the ventilation raise has broken through to the surface and the main fans have been commissioned.

13.5.2.1 Flame and Moth

The proposed layout for the Flame and Moth underground project supports a relatively simple positive pressure ventilation circuit. A primary fan located on the surface forces the heated air down the intake raises to each respective ventilation drive that intercepts the intake raise on the working levels. Each

production level is ventilated using an auxiliary fan that draws fresh air from the intake raise and directs the air through ducting to the working area before it returns to the main ramp to exhaust out the portal. Each of these ventilation drive connections must be regulated to ensure only the desired volume is permitted to flow.

One primary surface intake raise supports the Lightning and Christal zones and the Christal Zone utilizes a dedicated ventilation drive to connect to the fresh air system. Figure 13-10 shows the basic primary airflow through the fully developed mine.

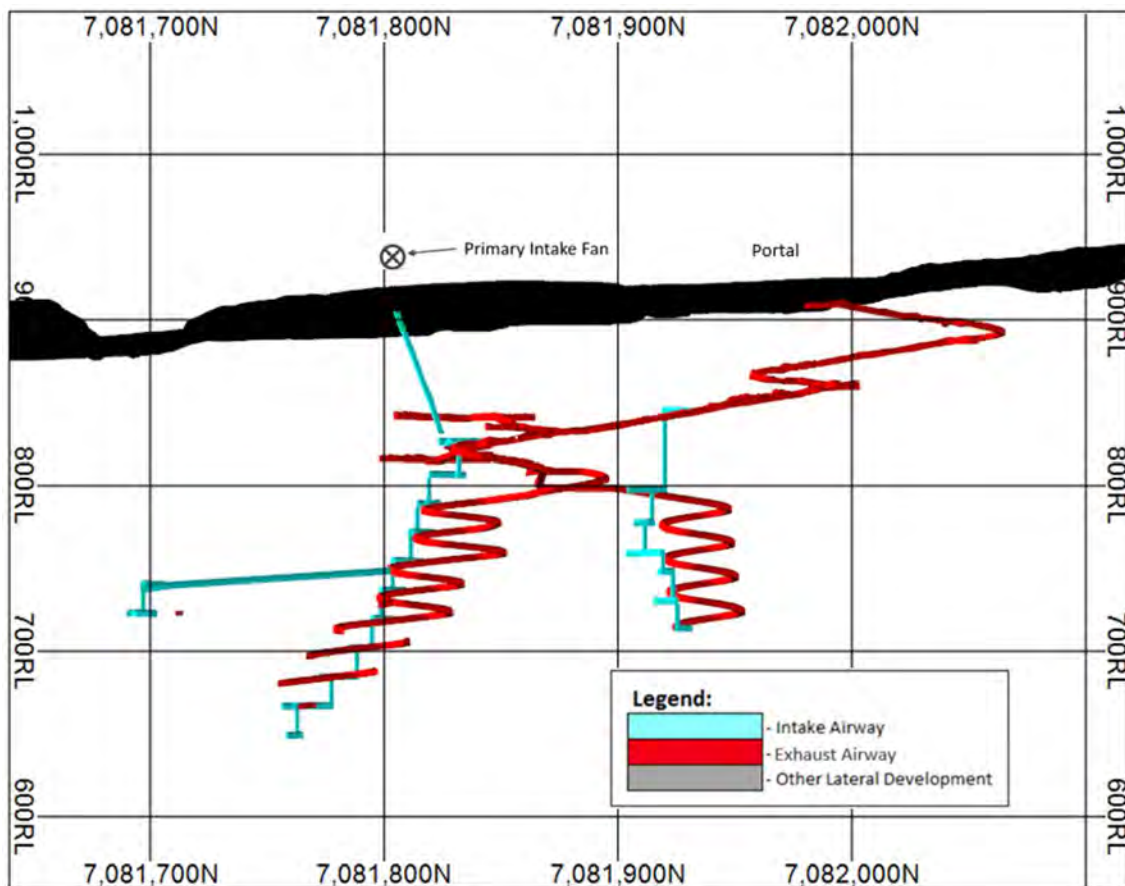

Figure 13-10 – Flame and Moth Primary Airflow Schematic.

Peak fan power for the Lightning intake surface raise is estimated to be 218 kW with an airflow of 117 m³/s.

13.5.2.2 Bermingham

The layout for the Bermingham underground project supports a relatively simple positive pressure ventilation circuit. Two fans located on the surface force heated air down the two intake raises to each respective ventilation drives that intercept the intake raise on the working levels. Each production level is ventilated using an auxiliary fan that draws fresh air from the intake raise and directs the air through ducting to the working area before it returns to the main ramp to exhaust out the portal. Each of these ventilation drive connections must be regulated to ensure only the desired volume is permitted to flow. Figure 13-11 shows the basic LOM primary airflow through the Bermingham.

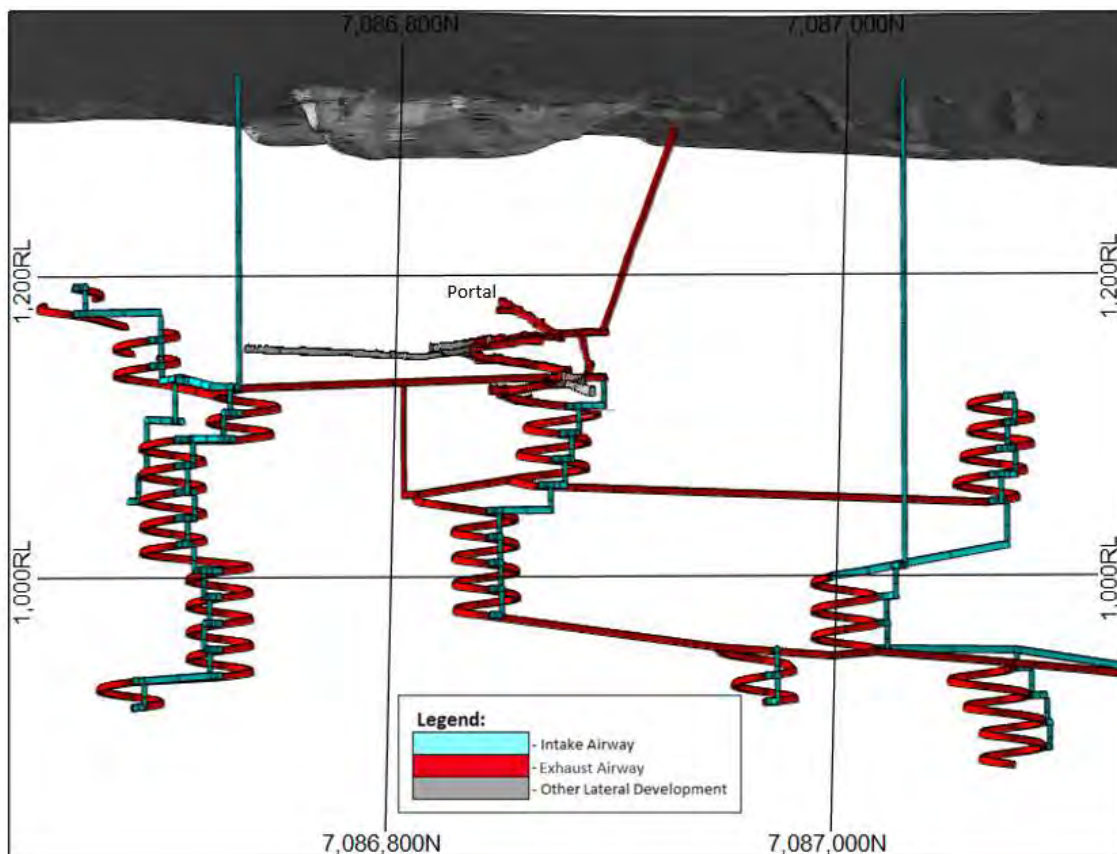

Figure 13-11 – Bermingham Primary Airflow Schematic.

Peak fan power for the Bermingham is estimated to be a combined 301 kW from the two fans. The larger fan has a projected flow of 111.9 m³/s with a power consumption of 233 kW and the second smaller fan has a projected flow of 67 m³/s with a power consumption of 84 kW.

13.6 MINE SERVICES

13.6.1 COMPRESSED AIR

Compressed air is supplied underground through 2" (51 mm) diameter HDPE pipes. At the Flame and Moth, the compressed air is supplied by a fixed air compressor associated with the mill. In the case of Bermingham, compressed air is supplied by an air compressor located underground.

13.6.2 DEWATERING

The Lucky Queen is located above the valley floor so total groundwater inflow is expected to be limited. Dewatering will still be required to remove service water from the underground. Bermingham and Flame and Moth are both expected to have higher groundwater flows. For the Flame and Moth, the maximum groundwater flow is expected to be 33 L/s. The Bermingham requires continual dewatering through the New Bermingham Portal, with discharge flows typically ranging between 3.0 and 10.0 L/s, a value of 11 L/s has been used for engineering purposes.

For all the mines, the dewatering strategy is to use electric submersible pumps or self-contained pump skids to collect water from sumps near the active mining areas and pump it in stages to the dirty water sump located on the ramp. Water is then pumped to the surface and directed to the water treatment plant installed near the portal. Water is treated to meet the effluent quality standards before being discharged to the ground.

13.6.3 POWER

All the mines are connected to the site and provincial power grid. Primary power transmission underground is 4,160 V to mobile power centers located in strategic locations underground where voltages are stepped down to 600 V for final distribution.

13.6.4 MAINTENANCE FACILITIES

For both Flame and Moth and Bermingham mines, the maintenance department has a fuel/lube truck, a mechanic's service truck, a tractor, and access to a scissor lift and a boom truck.

In addition to the mobile equipment, the mine maintenance department is responsible for the stationary equipment consisting of air compressors, main ventilation fans, propane air heaters, underground electrical distribution system, and main dewatering pumps.

Most of the mobile equipment maintenance is performed in a surface shop constructed near each of the mine portals.

13.7 MINING FLEET

All mobile equipment is diesel-powered rubber-tired equipment owned by Hecla.

Flame and Moth and Bermingham mines use equipment of similar size, whereas the Lucky Queen will utilize smaller-scale units. In order to avoid purchasing a new fleet of equipment for the Lucky Queen mine development and production, a contractor is expected to be engaged for these purposes.

Table 13-10 shows the underground equipment build-up by period and Table 13-11 shows the currently owned surface mobile equipment fleet which includes pickups and light equipment such as pumps, light plants, and miscellaneous equipment at the site.

Table 13-10 – Underground Equipment Fleet.

Type	Units	2024	2025	2026	2027	2028	2029	2030	2031	2032	2033	2034
Bolter	4	5	5	5	6	6	6	6	6	6	6	6
1 boom Jumbo	2	2	2	2	2	2	2	2	2	2	2	2
2 boom Jumbo	3	3	3	3	3	3	3	3	3	3	3	3
3yd LHD	7	7	7	7	9	9	9	9	9	9	9	9
6yd LHD	2	2	2	2	2	2	2	2	2	2	2	2
Haul Truck	5	5	5	5	6	6	6	6	6	6	6	6
Shotcrete Sprayer	3	3	3	3	3	3	3	3	3	3	3	3
Concrete Transmixer	2	3	3	4	4	4	4	4	4	4	4	4
Total Production Units	28	30	30	31	35	35	35	35	35	35	35	35
Skid Steer	1	1	1	1	2	2	2	2	2	2	2	2
Dozer	2	2	2	2	2	2	2	2	2	2	2	2
Telehandler	5	5	5	5	5	5	5	5	5	5	5	5
Tractors	1	1	1	1	2	2	2	2	2	2	2	2
Scissor Deck	5	5	5	5	5	5	5	5	5	5	5	5
UTV	13	13	13	13	16	16	16	16	16	16	16	16
Total Utility Units	27	27	27	27	32	32	32	32	32	32	32	32
Total Units	55	57	57	58	67	67	67	67	67	67	67	67

Table 13-11 – Surface Equipment Fleet.

Type	Units
Cement Truck	1
CAT Dozers	2
CAT Excavators	2
CAT Mini Excavator	1
CAT Electric Forklift	1
Generators (<100kW)	3
Cummins Generators (250-750 kW)	2
CAT Generators (100-350 kW)	2
CAT Grader	1
Volvo Haul Trucks	4
Light Vehicles	40
CAT Loaders	6
CAT Packer	1
Genie Scissor Deck	1
Skid Steer Loaders	5
Skandic Skidoo	2
Genie Telehandler	1
Trailers	7
Utility Vehicles	5
Miller Service Truck Welder	1
Water Trucks	2
Vacuum Trucks	2
Plow/Sander Truck	1
Hino Roll-off Truck	1
Gravel Truck	1
Kenworth Highway Truck	1

13.8 PERSONNEL

Hecla operates the mill as well as provides the technical services, management, and administration staff. All underground development and production are performed by Hecla. Table 13-12 shows the total estimated annual personnel for the Keno Hill Mine.

Table 13-12 – Estimated Annual Personnel Requirements for Keno Hill Mine.

Category	2024	2025	2026	2027	2028	2029	2030	2031	2032	2033	2034
Management/Admin	26	26	26	26	24	24	24	24	24	24	24
Mine General	140	140	140	140	140	140	140	140	140	140	70*
Lucky Queen											
Flame and Moth											
Birmingham											
Mill Operations	47	47	47	47	44	44	44	44	44	44	44
Site Services	20	20	20	20	17	17	17	17	17	17	17
Site Environmental	5	5	5	5	4	4	4	4	4	4	4
Health and Safety	5	5	5	5	4	4	4	4	4	4	4
Total	243	243	243	243	233	233	233	233	233	233	93

*Contractor mining at Lucky Queen.

13.9 OPERATIONS

Operations are performed by Hecla personnel using the company’s owned equipment 24 hours per day, 7 days per week with 4 crews rotating to site and staying at the Hecla Flat Creek camp. All mining activities are performed using mechanized methods; with the exception of bolting in small section headings where bolting is performed off of scissor lifts with stoper drills and jacklegs or using dedicated bolting platforms. All mucking is performed by diesel-powered load-haul dump units (LHDs) mucking to diesel-powered underground haul trucks. For the Lucky Queen and Birmingham mines ore is hauled to the portal and stockpiled on the surface where it is re-handled by Hecla’s surface truck fleet and loaders. Due to the proximity of the mill to the Flame and Moth, the underground fleet hauls the ore directly to the mill ore pad. Waste is hauled to the nearest backfill site underground or, if there are none available, hauled to the surface and stockpiled.

13.10 PRODUCTION SCHEDULE

The overall production schedule is based on feeding a consistent 400 to 550 tpd to the centrally located mill. The operations were sequenced to maximize Net Present Value and to minimize the number of operations concurrently active whilst satisfying the mill throughput targets. All references to Ore in this section are exclusively the Probable Mineral Reserves outlined in Chapter 12.

Table 13-13 shows the total life of mine mill feed for the underground operations.

Table 13-13 – LOM Plant Feed Summary.

Deposit	Ore Tonnes	Ag (g/t)	Au (g/t)	Pb (%)	Zn (%)
Lucky Queen	103,365	948	0.09	2.03	1.06
Flame and Moth	455,243	764	0.48	2.86	5.83
Birmingham	1,318,748	961	0.15	2.85	1.51
Total Plant Feed	1,877,356	912	0.22	2.81	2.53

Notes:

1. Rounding as required by reporting guidelines may result in apparent summation differences between tonnes, grade and contained metal content.
2. All Ore tonnes are Probable Mineral Reserves as shown in Section 12 of this report.
3. Tonnages are diluted and recovered.
4. Tonnage and grade measurements are in metric units.

Figure 13-12 shows the combined ore and waste tonnage profile over the project life. Figure 13-13 and Figure 13-14 show the LOM ore production by deposit along with the metal grade for silver and base metals respectively.

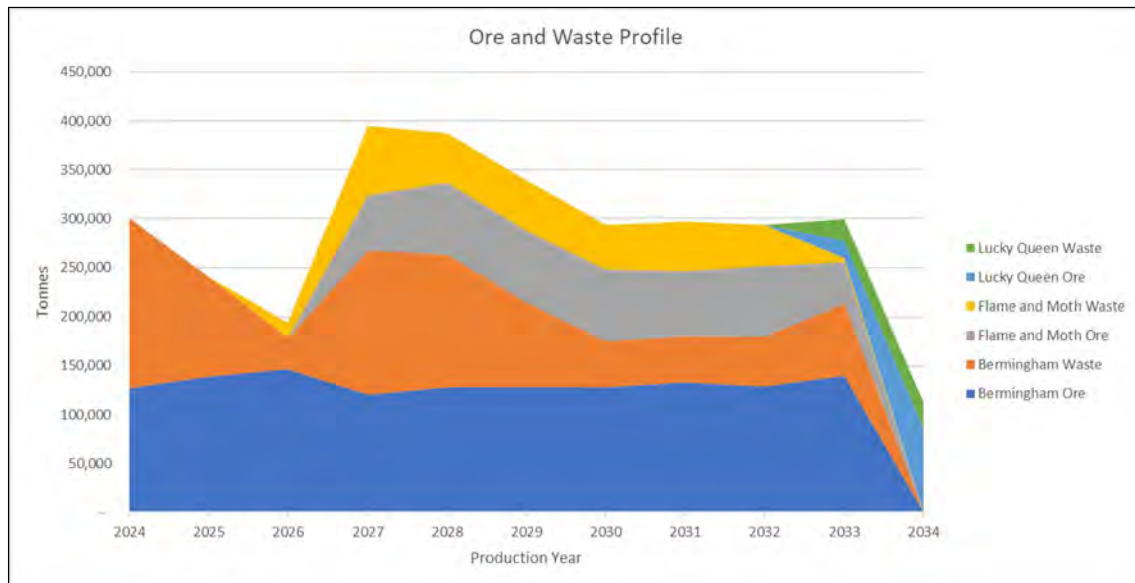

Figure 13-12 Ore and Waste Tonnes – Combined Mines.

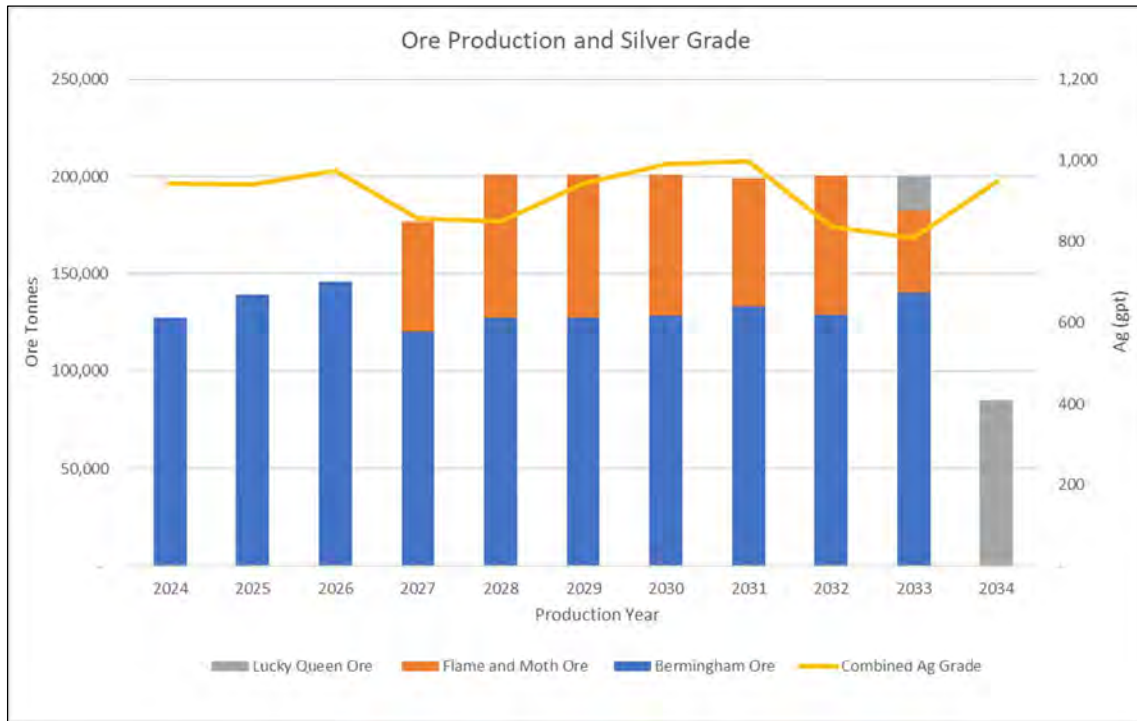

Figure 13-13 – Ore Tonnes vs. Silver Grade.

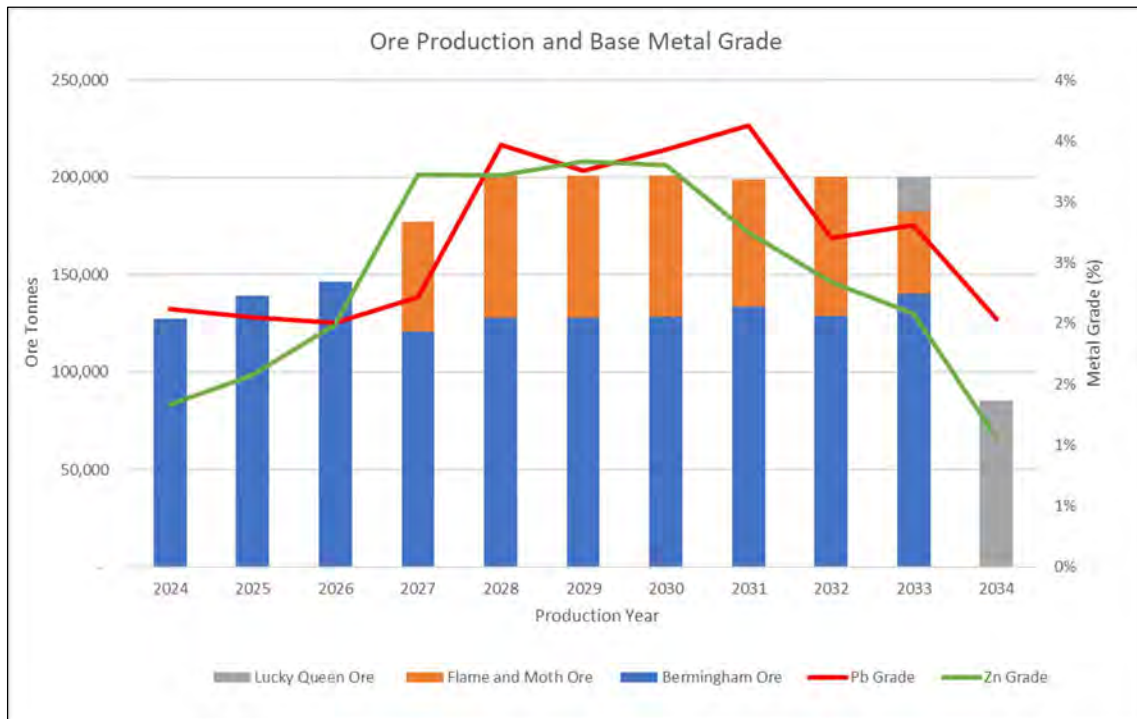

Figure 13-14 – Ore Tonnes vs. Base Metal Grade.

13.11 RECOMMENDATIONS

The QP notes that the overall mine plan benefits from increased flexibility and working fronts as the mine matures and the capital development advances. In the initial years, there is an opportunity to further de-risk the overall LOM plan and better predict the operational performance of future mining zones by addressing the following items:

- Undertake a more detailed dilution and extraction study, including consideration of any existing reconciliation studies, to better quantify the extraction recovery, dilution, and other modifying factors that Hecla is currently applying to all production designs. Specifically, the final cut underneath a planned sill can be expected to have a higher dilution from CRF failure due to blasting cycles of the final lift and previous lift. Use the results of the above noted studies to determine the actions necessary to align mine production grades with the Mineral Reserve Estimates.
- Complete additional geotechnical assessments to determine the amenability of the orebody to more productive and less costly mining methods. There is an opportunity to trial stope mining methods in the Flame and Moth between 2024 and 2026 to refine the method and application without affecting the overall LOM plan.
- Complete additional optimization on the Mineral Reserve mine plan and de-risk the mine plan on a development basis by assessing the potential for slower than planned increases to efficiency and underground unit development operations. Complete additional scenario scheduling to better understand the risk and plan appropriately to meet the schedule.
- Continue evaluating the option of mining at Flame and Moth deposit earlier than planned as a large portion of the underground access has been completed and the mine is ready to produce ore with minimal development. This will assist with reducing the LOM plan risk by creating additional mining fronts with minimal upfront capital.
- Continue conducting definition diamond drilling throughout the remainder of the underground mining operation to convert Inferred to Indicated Mineral Resources and increase the understanding of the mineralization. Doing so may result in increased Mineral Reserves near planned capital and operational development and reduce the overall capital development intensity of the schedule.
- Complete hydrogeological studies to better understand the sources of water at Flame and Bermingham
- Review mining plans and other relevant Hecla operations to define definitive actions to attain the planned improvements in mining productivity, daily development advance and associated costs over the first four years.

14. PROCESSING AND RECOVERY METHODS

The Keno Hill is of a polymetallic silver-lead-zinc vein-type mineralization. Silver predominantly occurs in argentiferous galena and argentiferous tetrahedrite, and to a lesser content, as native silver, and the silver-bearing minerals polybasite, stephanite, and pyrargyrite. Lead occurs in galena and zinc in sphalerite in either an iron-rich or iron-poor variety. Other sulfides identified at the Property include pyrite, pyrrhotite, arsenopyrite, and chalcopyrite. Common gangue minerals include siderite, quartz, and calcite in decreasing order of abundance (RPA, 2017).

The Keno Hill District Mill is currently operating with a LOM average throughput of 500 tpd according to the approximately 11-year mine plan for this technical report. The initial mill throughput is 400 tpd and ramp up to 550 tpd in year 5. The existing District Mill feed is produced from the Birmingham at 400 tpd, then increased by 100 tpd from the Flame and Moth supplying 200 tpd during most of the LOM and followed by the processing of Lucky Queen ore near the end of the project life. Details on the mine plan and production schedule are found in Chapter 13.

The original process flowsheet has been modified accordingly to allow the increased feed capacity. The process modifications were based on additional metallurgical test work described in Section 10, the experience from previous operations, as well as mill modifications and upgrades. This section (Section 14) describes the major processing design criteria, the modified flowsheet including recent modifications and upgrades, a general process description, process unit operation description, and annual production estimates.

14.1 PROCESS UNIT OPERATION DESCRIPTION

The Keno Hill District Mill is based on a conventional sequential flotation process producing lead and zinc concentrates. The silver concentrates are high in silver which typically accounts for approximately 90% to 95% of the mill feed silver values since silver is strongly associated with lead minerals. Overall, silver represents 70% to 80% of the value of the ores in the District.

Ore is crushed and then processed in a conventional flotation mill producing two concentrates: a silver-lead concentrate (aka silver concentrate) and a zinc concentrate. Concentrates are thickened, filtered, and trucked off-site for sale. Tailings are also thickened, filtered, and stored in a dry stack tailing facility (DSTF) adjacent to the mill.

Process water is stored in the mill pond adjacent to the mill complex and recycled to the plant for varied applications. The primary makeup water source is from the Flame and Moth underground mine which is treated within the existing water treatment plant. Excess water is discharged to either of two nearby drainage basins, Christal Creek, or Lightning Creek once the permitted water quality is achieved.

14.2 PROCESS FLOWSHEET AND DESCRIPTION

14.2.1 SIMPLIFIED PROCESS FLOWSHEET

The simplified process flowsheet of the mill complex is shown in Figure 14-1. The mill complex consists of the following process sections and unit operations:

- Primary and secondary crushing circuits with a radial stacker belt conveyor to transport the crushed ore to the covered fine ore stockpile.
- Draw down a pocket reclaiming the crushed ore from the covered fine ore stockpile.
- Two-stage grinding in a closed circuit with hydro-cyclones to produce a grinding product P80 size of 120 μm .
- A grinding classification circuit to produce a cyclone overflow to feed the lead rougher and rougher scavenger flotation circuit to recover lead and silver minerals. The process to produce lead rougher and lead rougher scavenger flotation concentrates which are reground to a P80 size of 30 μm .
- The reground lead rougher and lead rougher scavenger flotation concentrates are upgraded in three stages of cleaner flotation producing the final silver-bearing silver concentrate.
- The zinc rougher and the zinc rougher scavenger flotation circuit is fed by the lead rougher scavenger tailings and the lead 1st cleaner tailings to produce the zinc rougher concentrates and the final zinc rougher scavenger tailings.
- The zinc rougher concentrate is to be reground to a P80 size of 30 μm followed by upgrading in three stages of cleaner flotation. The cleaner circuit generates the final zinc concentrate and the zinc 1st cleaner scavenger tailings.
- Thickening and pressure filtration of the silver concentrate and the zinc concentrate.
- Thickening and pressure filtration of each of the zinc rougher scavenger and zinc 1st cleaner scavenger tailings, which are then disposed of on the surface as dry stack tailings underground as cemented backfill once the Cemented Rock Fill (CRF) plant is operating.
- A reagent preparation section.
- Utility distribution for compressed air and water distribution.

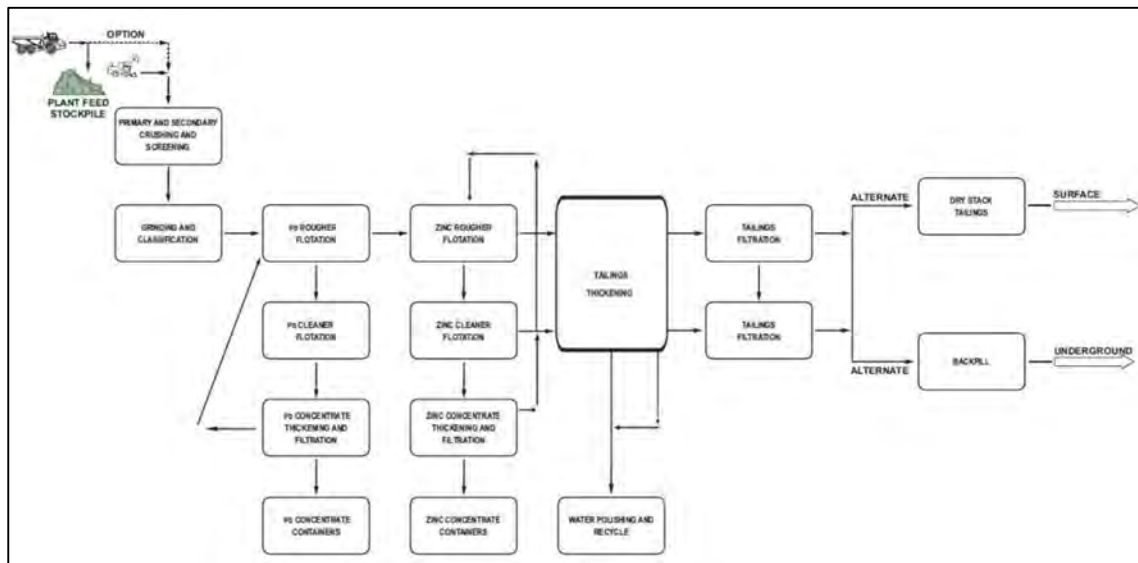

Figure 14-1 – Simplified Process Flow Diagram of the Mill Complex (Alexco, 2021b).

14.2.2 RUN OF MINE ORE CRUSHING, ORE STORAGE, AND RECLAIM

The crushing system is operated up to 12 h/d at a process rate of 50 t/h. The Run of Mine (ROM) ore is crushed in a two-stage crushing circuit closed with a vibrating screen. The final crushed product size P_{80} is 12 mm. ROM ore from Bermingham is dumped onto a ROM ore stockpile and then into the primary jaw crusher. The hopper is equipped with a stationary grizzly with a 450 mm aperture opening to prevent oversized ore from entering the downstream jaw crusher.

The primary crushing products, joined by the secondary crushing discharge, feed the sizing screen to produce the final crushed product. The oversize product from the sizing screen feeds the secondary cone crusher. The crushed material is conveyed to a fine ore stockpile with 550 t live capacity. Crushed ore reclaim is achieved via a draw-down pocket located beneath the fine ore stockpile.

14.2.3 PRIMARY GRINDING CIRCUIT

Crushed ore is reclaimed from the stockpile onto the ball mill feed conveyor belt at a nominal rate of 18.1 t per operating hour (434 tpd). The primary grinding circuit is a two-stage ball milling process producing a ground material with a P_{80} size of 100 to 120 μm . Ore from the ball mill discharges into the feed chute of the primary No.1 ball grinding mill which is a heavy-duty tire-driven type grinding mill 1,800 mm in diameter and 3,600 mm long, with an installed power of 150 kW. The primary mill slurry is discharged into a pump box and then pumped to join the secondary No.2 ball mill discharge.

The combined streams are pumped to the classifying cyclones. The cyclone underflow returns as feed to the secondary ball mill, while the cyclone overflow reports to the flotation circuit. Reagents (3418A and

zinc sulfide) are added to the ball mill feed to suppress zinc minerals during the lead mineral flotation stage.

The ball mill feed conveyor belt is sampled every shift to provide a head assay of the feed to the plant.

14.2.4 CLASSIFICATION

The primary and secondary ball mill discharges are combined in a common pump box and then feed a hydro-cyclone pack. Two cyclones are installed, each with a diameter of 250 mm. Operating in a mode of one running and one standby, the cyclone undersize material returns to the secondary grind ball mill by gravity, while the cyclone overflow with a P_{80} size between 100 and 120 μm gravity flows to the flotation circuit.

14.2.5 LEAD FLOTATION CIRCUIT

The lead flotation circuit produces a final silver concentrate through the stages of rougher flotation, rougher scavenger flotation, rougher scavenger concentrates regrinding, followed by three stages of cleaner flotation. Blower air is injected into each flotation cell mechanism. The reagents zinc sulfide, 3418A, SIPX, and MIBC are added to the circuit as required.

The flotation cells are existing units that were sized for the maximum laboratory-scale retention time for Bellekeno samples. Based on the locked cycle flotation test work completed by SGS, these cells are slightly oversized for the planned LOM mill feed which has lower lead head grades than the Bellekeno ore.

14.2.5.1 Lead Rougher and Rougher Scavenger Flotation

The cyclone overflow fraction from the primary grinding circuit is conditioned with the reagents 3418A and zinc sulfide in two agitated tanks. The pulp density is approximately 33% solids by weight. The residence time in the conditioning tanks is 5 minutes at the design volumetric flow rate.

The conditioned slurry then flows into the first of five 8 m^3 lead flotation tank cells with a total maximum residence time of 25 minutes based on test work. Should a shorter residence time be required, some of the cells can be taken off-line. Low-pressure blower air is injected into each cell mechanism to generate the froth for the flotation of lead and silver sulfide minerals.

The lead rougher concentrate from all the rougher cells and the lead rougher scavenger concentrate flow by gravity to a pump box and then feed the regrinding circuit. The lead rougher tailings report to the rougher scavenger flotation stage consisting of two 8 m^3 tank cells with a total maximum residence time

of 10 minutes. The rougher scavenger flotation tailings flow into a standpipe and are pumped to the zinc flotation circuit.

14.2.5.2 Lead Rougher Concentrate Regrind

The regrinding step prior to the lead 1st cleaner flotation further liberates silver and lead minerals from the gangue and other sulfide minerals to improve product quality and metal recovery. The lead rougher scavenger concentrates are pumped to a regrind ball mill which is 1,050 mm in diameter and 1,400 mm long powered by an 18-kW motor and is operated in a closed circuit with two 100 mm cyclones. One cyclone is in operation at any time and classifies the reground slurry. The regrind cyclone overflow flows to the lead 1st cleaner flotation cells while the cyclone underflow returns to the regrind ball mill for further grinding. The particle size target of the regrinding circuit is a P₈₀ size of about 30 µm.

14.2.5.3 Lead 1st Cleaner Flotation

The reground lead rougher scavenger concentrate and the lead 2nd cleaner flotation tailings are upgraded in the 1st cleaner flotation stage. The cleaner flotation feed gravitates from the lead regrind cyclone overflow into the feed box of the first of three 3 m³ 1st cleaner flotation cells where it is joined by the 2nd cleaner flotation tailings pumped from a standpipe. The 1st cleaner tailings report to the first conditioning tank of the zinc rougher flotation circuit, while the concentrate from the 1st cleaner stage feeds the 2nd cleaner flotation stage. The major equipment used in the 1st lead cleaner flotation circuit includes the following:

- Three 3 m³ conventional flotation cells.
- One 1,050 mm diameter and 1,400 mm long tire-driven regrind ball mill with 18 kW installed power.

The 1st cleaner flotation train has a total maximum residence time of 18 minutes. This residence time has been deemed adequate but can be reduced, if required, by taking flotation cells offline.

14.2.5.4 Lead 2nd Cleaner Flotation

The lead 1st cleaner concentrates and the lead 3rd cleaner flotation tailings are upgraded in the 2nd cleaner flotation stage. The 2nd cleaner tailings are recycled back to the 1st cleaner, while the 2nd cleaner flotation concentrate feeds the lead 3rd cleaner stage. The feed to the 2nd cleaner flotation circuit is the tailings from the 3rd cleaner flotation cell and the 1st cleaner concentrate. These cells are two 3 m³ cells. Blower air is injected into each cell mechanism. The 2nd cleaner flotation train has a total maximum residence time of 15 minutes. This residence time has been deemed adequate but can be reduced, if required, by

taking a flotation cell offline. The 2nd cleaner flotation concentrate flows into a standpipe which transfers the slurry to the 3rd cleaner flotation circuit.

14.2.5.5 Lead 3rd Cleaner Flotation

The lead 2nd cleaner concentrate is upgraded in the 3rd cleaner flotation stage. The 3rd cleaner tailings return by gravity to the 2nd lead cleaner flotation stage, while the concentrate is pumped to the silver concentrate thickener for dewatering.

The cleaner flotation feed is pumped from the 2nd cleaner circuit into the feed box of the 3 m³ cleaner flotation cell. The 3rd cleaner flotation cell has a residence time of 12 minutes. The 3rd cleaner flotation concentrate flows into a standpipe, which transfers the slurry to the silver concentrate dewatering circuit. The 3rd cleaner flotation tailings are recycled by gravity flow to the 2nd cleaner flotation circuit.

14.2.6 ZINC FLOTATION CIRCUIT

The zinc flotation circuit processes the tailings generated from the lead flotation circuit through the stages of rougher flotation, rougher scavenger flotation, rougher concentrate regrinding, followed by three stages of zinc cleaner flotation. Three products are produced, namely the final zinc concentrate, the zinc rougher scavenger tailings, and zinc 1st cleaner scavenger tailings which are filtered and either stored in the dry stack tailings facility or used as backfill once the CRF plant is operating. Blower air is injected into each cell mechanism.

Reagents copper sulfide, SIPX, lime, and MIBC are added to the circuit as required. The flotation area is equipped with a dedicated spillage sump and pump for clean-up purposes. The flotation cells are existing units sized on the maximum laboratory-scale retention time for Bellekeno samples, which is more than the required residence time based on the locked cycle flotation tests.

14.2.6.1 Zinc Rougher Flotation

Prior to zinc flotation, the zinc rougher flotation feed materials, consisting of lead rougher scavenger tailings, lead 1st cleaner tailings, and the returned zinc rougher scavenger tailings, are conditioned with copper sulfide to activate the depressed zinc minerals, and lime to suppress pyrite if required. The zinc rougher flotation stage generates a zinc rougher concentrate, and rougher scavenger flotation tailings which are low in pyrite and feed the corresponding dewatering circuit.

Two zinc flotation conditioning tanks are used in the operation. The conditioned slurry at a solids' density of 29% flows into the feed box of the first of four 8 m³ rougher flotation tank cells with a total residence

time of 40 minutes. Test work has indicated that a maximum residence time of 30 minutes is adequate for the flotation of the zinc sulfide minerals. However, should a shorter residence time be required, some of the cells can be taken off-line.

The zinc rougher flotation concentrate is transferred to a pump box by gravity to feed the zinc rougher concentrate regrinding circuit. The zinc rougher flotation tailings flow by gravity into the zinc rougher scavenger flotation cell.

14.2.6.2 Zinc Rougher Concentrate Regrind

As for the silver concentrate regrinding, the zinc rougher regrinding further liberates lead and zinc minerals from gangue and other sulfide minerals to improve concentrate product quality and metal recovery. The zinc rougher concentrates are pumped to a regrind ball mill of 1,050 mm in diameter and 1,400 mm long powered by an 18-kW motor, which is operated in a closed circuit with two 100 mm cyclones in the classification circuit. In operation, one cyclone classifies reground slurries. The regrind cyclone overflow flows to the zinc 1st cleaner flotation cells while the cyclone underflow returns to the zinc regrind ball mill. The P₈₀ particle size target of the regrinding circuit is around 30 µm.

14.2.6.3 Zinc 1st Cleaner Flotation and Zinc 1st Cleaner Scavenger Flotation

The zinc rougher flotation concentrate is further upgraded by three stages of cleaner flotation in a total of seven 3 m³ conventional flotation cells. The 1st cleaner scavenger flotation tailings have a high pyrite content, which is pumped to the No.2 dewatering circuit. The 2nd and 3rd cleaner tailings are recycled to the respective preceding cleaning stages by gravity flow. The zinc 3rd cleaner concentrate is the final product of zinc concentrate which is dewatered prior to shipping.

The feed box of the zinc 1st cleaner flotation feed receives three streams, namely:

- The zinc-regrinding cyclone overflows by gravity flow.
- The zinc 1st cleaner scavenger flotation concentrates by pumping.
- The zinc 2nd cleaner flotation tailings by gravity flow.

The 1st cleaner flotation train has three 3 m³ cells, which gives a total maximum residence time of 15 minutes. This residence time has been deemed adequate but can be reduced, if required, by taking flotation cells offline. The 1st cleaner flotation concentrate flows into a standpipe, which transfers the slurry to the zinc 2nd cleaner flotation circuit.

The zinc 1st cleaner tailings report to a cleaner scavenger flotation cell which is one 3 m³ tank with a total maximum residence time of 9 minutes. The cleaner scavenger flotation tailings flow into a standpipe and are pumped to the feed box of the zinc 1st zinc flotation circuit.

14.2.6.4 Zinc 2nd Cleaner Flotation

The zinc 1st cleaner flotation concentrate is further upgraded in the second cleaner flotation stage consisting of two 3 m³ conventional flotation cells.

The 2nd cleaner flotation feed is pumped from the zinc 1st cleaner flotation standpipe into the feed box of the first of two-zinc 2nd cleaner stage flotation cells. The zinc 2nd cleaner flotation train has a total maximum residence time of 15 minutes. This residence time has been deemed adequate but can be reduced, if required, by taking a flotation cell off-line. The 2nd cleaner flotation concentrate flows into a standpipe which transfers the slurry to the 3rd cleaner flotation circuit.

14.2.7 SILVER AND ZINC CONCENTRATES DEWATERING AND LOADOUT

14.2.7.1 Silver Concentrate

The final lead flotation concentrate is discharged to the lead 3rd cleaner concentrate standpipe and then pumped to the silver concentrate thickener. Flocculant is added as an aid in settling the solids. The thickener is a 3.05 m diameter high-rate unit fitted with an automated rake lifting mechanism and an auto-dilution system. It produces a thickener underflow density of 60% solids which are pumped to the silver concentrate filter feedstock tank. Thickener overflow solution flows into a lead process water collection tank and is pumped to the lead flotation circuit for re-use.

A 25 m³ holding tank holds the thickener underflow silver concentrate prior to dewatering by using a pressure filter. The concentrate filter feed tank has a residence time of 10 hours to provide sufficient time for regular maintenance on the silver concentrate filter. The filter is a 1,000 mm by 1,000 mm pressure filter unit with 9 plates. The slurry is pumped into the filter chambers on a batch basis, and the solution is squeezed out by high-pressure air. Then air is blown through to dry the cake to attain the required moisture level of 8%.

The filter cake is discharged periodically onto a stockpile. Samples are tested to determine the moisture content of the filter cake for metallurgical mass balance purposes. Filtrate from the filter is returned to the concentrate thickener. The dewatered silver concentrate is discharged to the covered silver concentrate stockpile, which has a storage capacity of seven days of silver concentrate production.

Filtrate from the pressure filter is pumped back to the thickener feed well as dilution water. The concentrate thickener overflow is distributed to the lead flotation circuit as process water. The silver concentrate dewatering area is equipped with a spillage sump for clean-up and recycling. Spillage is returned to the silver concentrate thickener.

14.2.7.2 Zinc Concentrate

The final zinc flotation concentrate is discharged to the zinc 3rd cleaner concentrate standpipe and then pumped to the zinc concentrate thickener. Flocculant is added as an aid in settling the solids. The thickener is a 3.05 m diameter high-rate unit fitted with an automated rake lifting mechanism and an auto-dilution system. It produces a thickener underflow density of 60% solids, which are pumped to the zinc concentrate filter feedstock tank. The thickener overflow solution flows into a process water collection tank and is pumped to the zinc flotation circuit for re-use.

A 25 m³ holding tank holds the thickener underflow zinc concentrate prior to dewatering by a pressure filter. The concentrate filter feed tank has a residence time of 10 hours to provide sufficient time for regular maintenance of the zinc concentrate filter. The filter is a 1,000 mm by 1,000 mm pressure filter unit with 9 plates. The slurry is pumped into the filter chambers on a batch basis, and the solution is squeezed out by high-pressure air. Then air is blown through to dry the cake to attain the required moisture level of 8%.

The filter cake is discharged periodically onto a concentrate stockpile. Samples are tested for the moisture content of the filter cake and to determine the concentrate grade used for metallurgical mass balance. Filtrate from the filter is returned to the zinc concentrate thickener. The dewatered zinc concentrate discharges to the covered zinc concentrate stockpile which has a storage capacity of approximately seven days of zinc concentrate production.

Filtrate from the pressure filter is pumped back to the thickener feed well as dilution water. The concentrate thickener overflow is distributed to the zinc flotation circuit as process water. The zinc concentrate dewatering area is equipped with a dedicated spillage sump and pump for clean-up purposes. Spillage is returned to the zinc concentrate thickener.

14.2.7.3 Tailings Dewatering and Handling

The tailing's thickening area is equipped with one dedicated spillage sump and pump for clean-up purposes. The spillage is returned to one of the two tailings thickeners.

The zinc 1st cleaner scavenger tailings feed the No.2 tailings thickener where it is combined with a flocculant solution to aid the settling. The thickener is a 3.05 m in diameter high-rate type, allowing for the thickener underflow density of 58% solids to be produced ahead of the filtration stage. Thickener overflow solution flows via gravity into the water polishing/settling pond. Thickener underflow slurry is pumped to a tailings storage tank and then pumped to No.2 tailings filter presses for dewatering. The filtrate solution from the filter press is collected in a filtrate standpipe and returned to the No.2 tailings thickener as dilution water.

Similarly, the zinc rougher scavenger tailings standpipe feeds the No. 1 tailings thickener, where it is combined with flocculant to aid settling. The thickener is 6.1 m diameter, and high-rate type, allowing for

a thickener underflow density of 58% solids to be produced ahead of the filtration stage. Thickener overflow solution flows via gravity into the water polishing/settling pond. Thickener underflow slurry is pumped to a tailings storage tank and then pumped to the No. 1 tailings filter press for dewatering. Filtrate solution from the filter is collected into a filtrate standpipe and returned to the No. 1 thickener as dilution water.

Both tailings’ filters discharge onto the filtered tailings belt conveyer. The tailings filter products have a greater than 88% solids content, which is suitable for disposal by truck from the stockpile to either the underground as cemented tailings backfill once the CRF plant is operating or the dry stack tailings facility.

The major equipment for tailings management includes:

- One 3,050 mm diameter tailings thickener (No.2 Tailings Thickener).
- One 6,100 mm diameter tailings thickener (No. 1 Tailings Thickener).
- One 1,250 mm by 1,250 mm pressure filter with 23 plates (No. 2 Tailings Filter Press).
- One 1,250 mm by 1,250 mm pressure filter with 23 plates (No. 1 Tailings Filter Press).

14.2.7.4 Reagent Handling and Storage

Most reagents are received in bulk in palletized bags, chemical containers, drums, or bulk bags. The covered and curbed reagent storage and preparation area is located adjacent to the flotation area. A forklift with a drum handler attachment is used for reagent handling, while the electric hoist servicing the reagent area lifts the reagents to the respective reagent mixing area located above the mixed reagent storage area. The reagent system includes unloading and storage facilities, mixing tanks, transfer pumps, and feeding equipment. Table 14-1 shows the reagents currently being specified for use in the process plant.

Table 14-1 – Summary of Reagents.

Reagent	Preparation Method	Use
Flocculant	Received as powder in 25 kg bags; mixed to 0.3% storing strength; transferred to a storage tank and dosed directly to thickeners following further dilution to 0.03% dosing strength.	Flocculation of flotation tailings, and flotation lead and zinc concentrates, in thickeners.
Copper Sulfide	Received as powder in 25 kg bags; mixed to 10% strength; transferred to a storage tank. Dosed to the zinc flotation circuit.	Regulator for zinc sulfide minerals in the flotation process.
MIBC	Received as a liquid in 200 L drums; dosed undiluted to lead and zinc flotation circuits.	Promotion and stabilization of froth bubbles in flotation cells.
SIBX	Received as powder in 25 kg bags; mixed to 10% strength; transferred to a storage tank. Dosed to both lead and zinc flotation circuits.	Collector reagent for sulfide minerals into the froth phase of the flotation cells.
3418A	Received as a liquid in 200 L drums; dosed undiluted to lead flotation circuit.	Additional collector reagent for lead and silver sulfide minerals into the froth phase of the flotation cells.
Zinc Sulfide	Received as powder in 25 kg bags; mixed to 10% solution strength; transferred to a storage tank. Dosed to the primary grinding and lead flotation circuit, if required.	Regulator of lead sulfide minerals in the flotation process.

Reagent	Preparation Method	Use
Lime	Received as powder in 1 t bags, mixed to 20% storing strength; transferred to a storage tank and dosed directly to the lead regrind and zinc flotation circuits.	pH control and pyrite depressant; added as required
Carbon Dioxide	Received in 240 L compressed gas cylinders. Dosed to lead process water.	pH control to prevent sphalerite activation in the lead flotation circuit.

Anti-scaling chemicals may be required to minimize scale build-up in the reclaim or recycle water lines. This reagent is delivered in liquid form and metered directly into the reclaim water tank.

14.2.8 MILL CHANGES

No major changes occurred to the mill complex as built in 2010 during its initial operation period. During the temporary shutdown in 2013, a series of corrective maintenance projects were completed in preparation for the restarting the mill. The major maintenance works completed at that time included rebuilding all the flotation cells and pumps. The grinding circuit was upgraded with the installation of a second ball mill among a cyclone cluster replacing a Derrick screen deck to be able to handle increased throughput. Lead and zinc rougher concentrate regrind circuits were installed including a ball mill and a classification stage for each of the concentrates. The final tailings press filter was replaced with a larger unit to increase capacity.

In 2018, a water treatment circuit was installed inside the existing mill building to treat water from Flame and Moth, the water treatment consists of a clarifier and reagent addition system (lime and flocculant) for treating the water prior to discharge or recycle into the mill process water tank.

14.2.8.1 Grinding Circuit

Three specific modifications have been completed to ensure mill throughput including:

- Replacement of the existing ball mill separation screen to classifying cyclones.
- Modification of the existing ball mill discharge.
- Addition of one ball mill to the grinding circuit in series with the existing ball mill in an open circuit configuration.

The modifications were based on both grinding test work and a review of the planned mill feed/throughput for the LOM. Starkey & Associates (S&A) of Oakville, Ontario, performed a grinding circuit throughput analysis in 2013. In the investigation, the Bond rod mill work index was found as 12.4 kWh/t; while the Bond ball mill work index was measured as 10.20 kWh/t. Both the working indices are noticeably higher than the 2009 design of 8.7 kWh/r (RWi) and 9.5 kWh/t (BW_i).

The S&A assessment was expanded using International Metallurgical in 2018 and formed the basis for the changes to the mill equipment. International Metallurgical evaluated the conversion of the existing grate discharge of the primary ball mill to supplement the second ball mill installation. The assessment also included the replacement of the vibrating Derrick screen with two cyclones. Based on an overall Bond Work index of 11.0 kWh/t from previous operations and grindability testing (S&A, 2013), the two-stage ball mill grinding performance was estimated to reduce the feed size F80 of 6 mm to 80% passing 120 µm in the cyclone overflow.

The QP reviewed the planned grinding circuit, which was comprised of two identical overflow ball mills, each with a dimension of 1.8 m diameter x 3.6 m, and an installed power of 150 kW. Estimation of the feed size F80 at 10 mm and an overall BWi of 10.5 kWh/t, the two-stage ball mill grinding circuit will achieve 600 tpd. The particle size of the ground product will contain 80% passing 100 to 120 µm.

14.2.8.2 Flotation Circuit

Two major modifications were completed in the flotation circuit based on the recent test results. The first modification was to divert the lead 1st cleaner scavenger tailings to feed the zinc rougher flotation circuit.

The second modification was to add two regrind ball mills to the current lead and zinc flotation circuit, one for each of the lead and zinc concentrates prior to the cleaning stage. This was based on an analysis of the metallurgical test work conducted from 2016 to 2019 on representative samples of both the Flame and Moth and Bermingham deposits, and composites thereof (Section 10). Regrinding of each of the lead and zinc rougher concentrates improved the grade of the final zinc concentrate and lowered the zinc reporting to silver concentrate. This was particularly beneficial for the Flame and Moth ore.

14.2.8.3 Dewatering Circuit

Plate and frame pressure filters were used for the dewatering of both the lead and zinc concentrates and the tailings' products. The circuit was modified to replace the smaller of the two existing filter presses (1,000 x 1,000 mm, 9 plates) with a larger filter press (1,250 x 1,250 mm, 23 plates) to mirror the size of the second filter press.

14.3 PROCESS DESIGN CRITERIA

The District Mill is designed for 400 tpd mill throughput, and the plant operates at 400 tpd for the first five years before ramping up to 550 tpd. The mill complex processes ore at a 75% availability for the crushing plant based on one 12-hour shift per day, and 92% availability for the grinding and flotation plant operating 24 hours per day.

The primary grinding is conducted in two stages with a target grind size P_{80} of 100 to 120 μm . Concentrate regrind mills are added to each of the lead and zinc flotation circuits to further liberate lead and zinc minerals. The regrinding particle size P_{80} was designed as 30 μm for the lead rougher concentrates and 30 μm for the zinc concentrates. The key design criteria are shown in Table 14-2.

Table 14-2 – Modified Mill Design Criteria (Hecla, 2024).

Descriptions	Unit	Values
Daily Processing Rate	tpd	400 (ramping up to 550 tpd in year 5)
Annual Operating Days	d/y	365
Operating Schedule – Crushing		1 shift per day (12 h/shift)
Operating Schedule – Grinding/Flotation		2 shifts per day (12 h/shift)
Crushing Availability	%	75
Grinding/Flotation Availability	%	92
Head Grades, LOM Average		
Ag Grade	g/t	912
Au Grade	g/t	0.22
Pb Grade	%	2.81
Zn Grade	%	2.53
Bond Ball Mill Work Index	kWh/t	10.5
Grinding		
Feed Particle Size P80	μm	12,000
Product Particle Size P80	μm	100 to 120
Regrinding		
Lead Rougher Concentrate Particle Size P80	μm	30
Zinc Rougher Concentrate Particle Size P80	μm	30
Flotation Stages		Pb Ro/3-stage cleaner flotation followed by Zn Ro/3-stage cleaner flotation
Tailings Management		
Tailings		Surface Dry Stack, with portion of Flame and Moth tailings used for underground backfill

14.3.1 MILL DESIGN CRITERIA

The District Mill design criteria for the mill operations are summarized in Table 14-3.

Table 14-3 – Mill Design Criteria.

Description	Unit	Value
Type of Ore Processed		
Silver/Lead/Zinc sulfide mineralization		
Birmingham/Lucky Queen/Flame and Moth Mines		
Ore Characteristics		
Specific Gravity	g/cm ³	3.46
Bulk Density	t/m ³	2.1
Moisture Content	%	3-5
Operating Schedule		
<i>Crusher Plant</i>		
Shift/Day		1
Hours/Shift between 7:00 am and 7:00 pm only	h	12
Hours/Day	h	12
<i>Grinding and Flotation Plant</i>		
Shift/Day		2
Hours/Shift	h	12
Hours/Day	h	24
Days/Year	day	365
Plant Availability/Utilization		
Overall Plant Feed	mt/a	146,000
Overall Plant Feed	mt/d	250-400
Crusher Plant Availability	%	80
Grinding and Flotation Plant Availability	%	92
Crushing Process Rate	mt/h	63.8
Grinding/Flotation Process Rate	mt/h	18.5

The daily concentrate grade, metal recovery rates, and production rates are provided in Table 14-4.

Table 14-4 – Concentrate Production (Hecla, 2024).

Description	Unit	Value
Head Grades	% Pb	2.76-2.86
	% Zn	1.06-2.39
	g/t Au	0
	g/t Ag	885-963
Recovery (LOM)	Pb %	93.2
	Zn %	72
Recovery (LOM) including Ag & Zn Concentrates	Au %	0
Recovery (LOM) including Ag & Zn Concentrates	Ag %	96

Description	Unit	Value
Silver Concentrate Grade (LOM)	% Pb	45
	% Zn	1.84
	g/t Au	0
	g/t Ag	15,269
Zinc Concentrate Grade (LOM)	% Pb	4.02
	% Zn	47
	g/t Au	0
	g/t Ag	997
Silver Concentrate Production (LOM)	wmt/a	11,000
Zinc Concentrate Production (LOM)	wmt/a	7,000

14.4 SUMMARY OF MASS AND WATER BALANCES

14.4.1 PLANT SERVICES

14.4.1.1 Air Supply

The air service systems supply the required air in the following areas.

- Flotation: low-pressure air for flotation cells is provided by air blowers.
- Filtering: high-pressure air for filter pressing and drying of concentrates and tailings is provided by a dedicated air compressor.
- Crushing: high-pressure air is provided for the baghouse filters in the crushing facility.
- Instrumentation: dried and oil-free instrument air comes from the plant air compressors and is stored in a dedicated air receiver.

Two 365 cfm compressors, each with 75 kW motors, supply the high-pressure air used in plant operations and instrumentation. The compressed air is filtered and then stored in dedicated air receivers. For instrumentation air, an additional drying stage is required. A low-pressure centrifugal blower is used to supply low-pressure air to the various flotation circuits.

14.4.1.2 Instrumentation and Process Control

The plant process control system consists of individual locally mounted control panels located near the main equipment. The mill control system includes an Allen Bradley PLC (programmable logic controller) that provides local and centralized start/stop control. Major process performance including throughput, mill power draw, and motor variable speeds are displayed on the centralized computer within the mill operator control room. Alarm annunciation is local to the major equipment or located on the local control

panel. The local control panels act as a marshaling point for monitoring and control of the nearby equipment and instrumentation. It also acts as a distribution point of power for instrumentation.

14.4.1.3 Quality Control

A metallurgical and assay laboratory conducts daily quality control and optimizes process performance. The assay laboratory is equipped with the necessary analytical instruments to provide all the routine assays for the mine samples, the geological samples, the process plant samples, and samples taken for environmental monitoring. The metallurgical laboratory undertakes all basic test work to monitor metallurgical performance and to improve the process flowsheet and efficiencies.

14.5 PRODUCTS AND RECOVERIES

According to the current LOM plan, three deposits are considered to provide the future mill feed, namely, the Flame and Moth (26% of the total mill feed), Bermingham (69%), and Lucky Queen (5%).

The concentrate grades and recoveries are based on the test work and recovery relationships presented in Section 10. As shown in Table 14-5, the overall LOM silver concentrate has an expected grade of 15,269 g/t Ag and 45% Pb. The zinc concentrate is expected to contain a grade of 47% Zn and 997 g/t Ag. Based on this distribution and metal projections given in Section 10, the LOM concentrate production is provided in Table 14-6.

The locked cycle testing completed in 2017 and 2018 was analyzed for penalty elements including: As, Bi, Sb, Hg, F, SiO₂, Mn, Fe, Cd, and Zn (in Pb). Based on initial smelter terms discussions, the silver concentrate only showed slightly elevated As, Bi, and Sb, while the zinc concentrate only showed slightly elevated As and Cd. No penalties were applied to the payable metals in this technical report based on the predicted metallurgical performance. Details of the annual and LOM total concentrate production and metal recoveries to concentrates are shown in Table 14-6 and Table 14-7.

Table 14-5 – LOM Projected Concentrate Grades (Hecla, 2024).

	LOM
Ag-Pb Concentrate	
Dry tonnes	103,199
Ag g/t	15,269
Pb %	45.0
Zn Concentrate	
Dry tonnes	68,748
Ag g/t	997
Pb %	4.02
Zn %	47.0

Notes:

1. Based on the Probable Mineral Reserves presented in Section 12 and the mine plan presented in Section 13.
2. Grades are calculated weighted averages.

Table 14-6 – LOM Projected Concentrate Production (Hecla, 2024).

Products	Unit	Total or Average	2024	2025	2026	2027	2028	2029	2030	2031	2032	2033	2034
Mill Feed (total)	t	1,877,356	127,307	139,259	146,136	176,937	200,803	200,879	200,917	199,076	200,234	200,443	85,365
Mill Feed Head Grades													
Ag	g/t	912	944	941	974	855	849	944	990	998	835	808	948
Pb	%	2.81	2.11	2.05	2.00	2.22	3.47	3.25	3.43	3.63	2.70	2.81	2.03
Zn	%	2.53	1.34	1.58	1.99	3.23	3.22	3.33	3.30	2.74	2.34	2.08	1.06
Recoveries to Ag-Pb Concentrates													
Ag	%	92.0	92.0	92.0	92.0	92.0	92.0	92.0	92.0	92.0	92.0	92.0	92.0
Pb	%	88.0	88.0	88.0	88.0	88.0	88.0	88.0	88.0	88.0	88.0	88.0	88.0
Zn	%	4.0	4.0	4.0	4.0	4.0	4.0	4.0	4.0	4.0	4.0	4.0	4.0
Recoveries to Zn Concentrates													
Ag	%	4.0	4.0	4.0	4.0	4.0	4.0	4.0	4.0	4.0	4.0	4.0	4.0
Pb	%	5.2	5.2	5.2	5.2	5.2	5.2	5.2	5.2	5.2	5.2	5.2	5.2
Zn	%	68.0	68.0	68.0	68.0	68.0	68.0	68.0	68.0	68.0	68.0	68.0	68.0

Notes:

1. Based on the Probable Mineral Reserves presented in Section 12 and the mine plan presented in Section 13.
2. Partial year of production is Year 11.

Table 14-7 – LOM Projected Concentrate Production - Metal Quantities Hecla, 2024).

Products	Unit	Total	2024	2025	2026	2027	2028	2029	2030	2031	2032	2033	2034
Metals Recovered in Ag Pb Concentrate													
Ag	M oz	50.66	3.55	3.88	4.21	4.48	5.04	5.61	5.89	5.88	4.95	4.79	2.39
Pb	tonnes	46,440	2,369	2,514	2,573	3,450	6,127	5,748	6,069	6,357	4,758	4,948	1,527
Zn	tonnes	1,901	68	88	116	228	259	268	265	218	187	167	36
Metals Recovered in Zn Concentrate													
Ag	M oz	2.20	0.15	0.17	0.18	0.19	0.22	0.24	0.26	0.26	0.22	0.21	0.10
Pb	tonnes	2,765	141	150	153	205	365	342	361	379	283	295	91
Zn	tonnes	32,311	1,157	1,493	1,975	3,881	4,397	4,554	4,504	3,714	3,187	2,833	616
Total Recovered Metals													
Ag	M oz	52.87	3.71	4.05	4.39	4.67	5.26	5.85	6.14	6.13	5.16	5.00	2.50
Pb	tonnes	49,205	2,510	2,664	2,726	3,655	6,492	6,090	6,430	6,735	5,042	5,243	1,618
Zn	tonnes	34,212	1,225	1,581	2,091	4,110	4,656	4,822	4,769	3,933	3,374	2,999	652

Notes:

1. Based on the Probable Mineral Reserves presented in Section 12 and the mine plan presented in Section 13.
2. Partial years of production is 11.

14.6 RECOMMENDATIONS

The QP considers that there is an opportunity to improve the level of detail of the metallurgical predictions and particularly the concentrate production at a month-to-month operational level. Further locked cycle tests at the next stage of study are recommended for samples representing the Flame and Moth deposit and different blends according to the LOM production plan. There may be an opportunity to improve the concentrates grades with further testing, particularly of the zinc concentrate. Additional metallurgical testing at different head grades would also support the approach to capping recoveries, particularly for the compartment of lead to concentrates at lower head grade mill feed. In addition, further hardness tests are recommended on these samples to verify potential grindability variations for future mill feeds. It is also recommended that testing of the increased plant throughput above the 400 tpd be done in the first year of operation to identify potential bottlenecks and confirm requirements for mill modifications to achieve the 550 tpd throughput. Sedgman recommends that Hecla perform a series of debottlenecking exercises and productivity tests on the mill prior to and well in advance of the expected throughput increases. This will help to de-risk the production profile and ensure a smooth ramp up.

15. INFRASTRUCTURE

15.1 ACCESS ROADS

15.1.1 OFF-SITE FACILITIES

The Keno Hill Mine is located in central Yukon, near the community of Keno City. Keno Hill is approximately 452 highway kilometers or approximately 5 hours by road north of Whitehorse via Yukon Highway 2 and Highway 11. Road access to the project is maintained year-round by the Yukon Government, Department of Highways. The site operations are supported by an existing office and administrative building located in Whitehorse.

The nearest airport with scheduled service is the Mayo Airport, located approximately 55 kilometers south of the site. Charter flights between Whitehorse and Mayo also utilize this airport.

15.1.2 AREA HAUL ROAD SYSTEM

The former operator, Alexco, has constructed a series of access and haul roads to route mine traffic around the Keno City community (Figure 15-1). All traffic between Elsa and the mill facility is routed along the Christal Lake Road and subsequently the Bellekeno haul road. The Birmingham traffic uses the Birmingham access road, Calumet Road, and a short section of the Duncan Creek Road (~3 km) between the mill and the Birmingham deposit.

Heavy truck traffic from Lucky Queen will be routed along the Keno City bypass road to/from the Bellekeno haul road. The bypass road is approximately 2.1 km long and six to nine meters wide as per Yukon Workers' Compensation Health and Safety Board regulations and the identified haul road type.

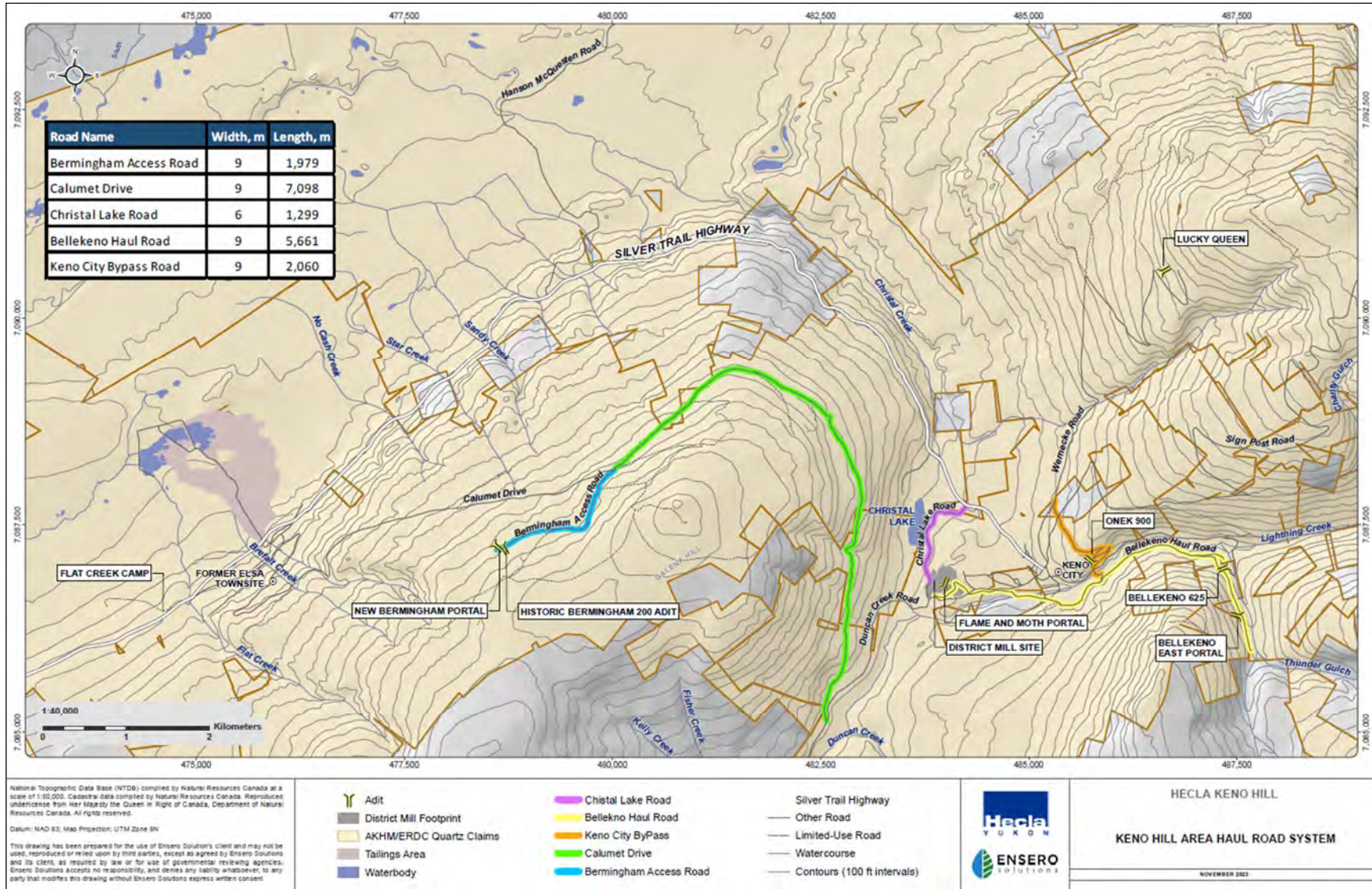

Figure 15-1 – Keno Hill Area Haul Road System.

15.2 ELECTRICAL POWER SUPPLY AND DISTRIBUTION

The Keno Hill Mine is supplied with electrical power from a hydroelectric plant near Mayo and a connection to the Yukon-wide electrical grid.

The Mayo hydro facility was expanded in 2011 which increased generation capacity from 5 megawatts to 15 megawatts. The power distribution grid was also upgraded from Pelly Crossing to Stewart Crossing during the same time. The power distribution line from Mayo to McQuesten was completed in early 2021 to replace the 65-year-old line and to add system protection equipment. There is ample power supply on the grid to operate in the future at 550 tpd.

A new 69 kV/4.16 kV 3 MVA substation was installed to deliver power to the mill facility, Flame and Moth, and associated infrastructure. The substation houses a primary 69 kilovolt – 600-volt step-down transformer and electrical distribution infrastructure. The substation is enclosed by a 28 by 15.5-meter security fence.

Hecla owns several substations in the area, including the Elsa substation, the Onek substation, and the Bellekeno 625 portal substation. Hecla also owns the transmission line connecting the latter two. Power for the Flame and Moth is now provided exclusively by the Yukon Energy Corporation (YEC) electrical distribution system.

Birmingham power is fed from the Ruby substation that has 69kV/4.16kV 3 MVA capacity. The main transmission line is via a surface teck cable that runs up the slope from the Ruby substation to the mine site (shown in Figure 15-6).

Power for the camp is supplied from the local grid that runs through Elsa to Keno City.

15.3 COMMUNICATIONS

Communications are via satellite with good bandwidth, optimized internet for the operations network, and cell phone coverage. Cell phone boosters are installed in many locations to provide enhanced coverage. Mobile VHF radios are carried by most personnel, and available in all surface and most underground vehicles, as well as base radios in all buildings at the site. A voice-over IP (VoIP) telephone network is also available.

15.4 ON-SITE INFRASTRUCTURE

The District Mill facility is a centrally located complex serving the Keno Hill Mine. The current facilities at the District Mill facility include mine and mill offices, male and female dry facilities, an assay lab, first aid

facilities, and the mill and DSTF complex (Figure 15-4). Flame and Moth mine portal is also located in this area.

Other existing infrastructure at the site includes:

- A network of public and private roads connecting the mines, process plants, and other facilities including the Silver Trail Highway.
- Administration, maintenance, and camp facilities near the town of Elsa.
- Mine workings and infrastructure including water treatment at the Bellekeno.
- Mine workings and minor surface buildings at the Lucky Queen.
- Portal and decline development at both Flame and Moth and Bermingham.
- Waste rock storage facility at the Lucky Queen, Bellekeno, and Bermingham.
- Crushing plant and flotation processing plant.
- DSTF adjacent to the process plant.
- Process and potable water sources.
- Electrical power available in the area from the Yukon Electrical Company Limited grid.

Mine surface and underground infrastructure are currently in serviceable condition and are in use.

The site layout for each property at Keno Hill is presented below as follows:

- Bellekeno – Figure 15-2.
- Lucky Queen – Figure 15-3.
- Flame and Moth and Mill District – Figure 15-4.
- Onek – Figure 15-5.
- Bermingham – Figure 15-6.

The details on each site’s infrastructure are provided in the sections below.

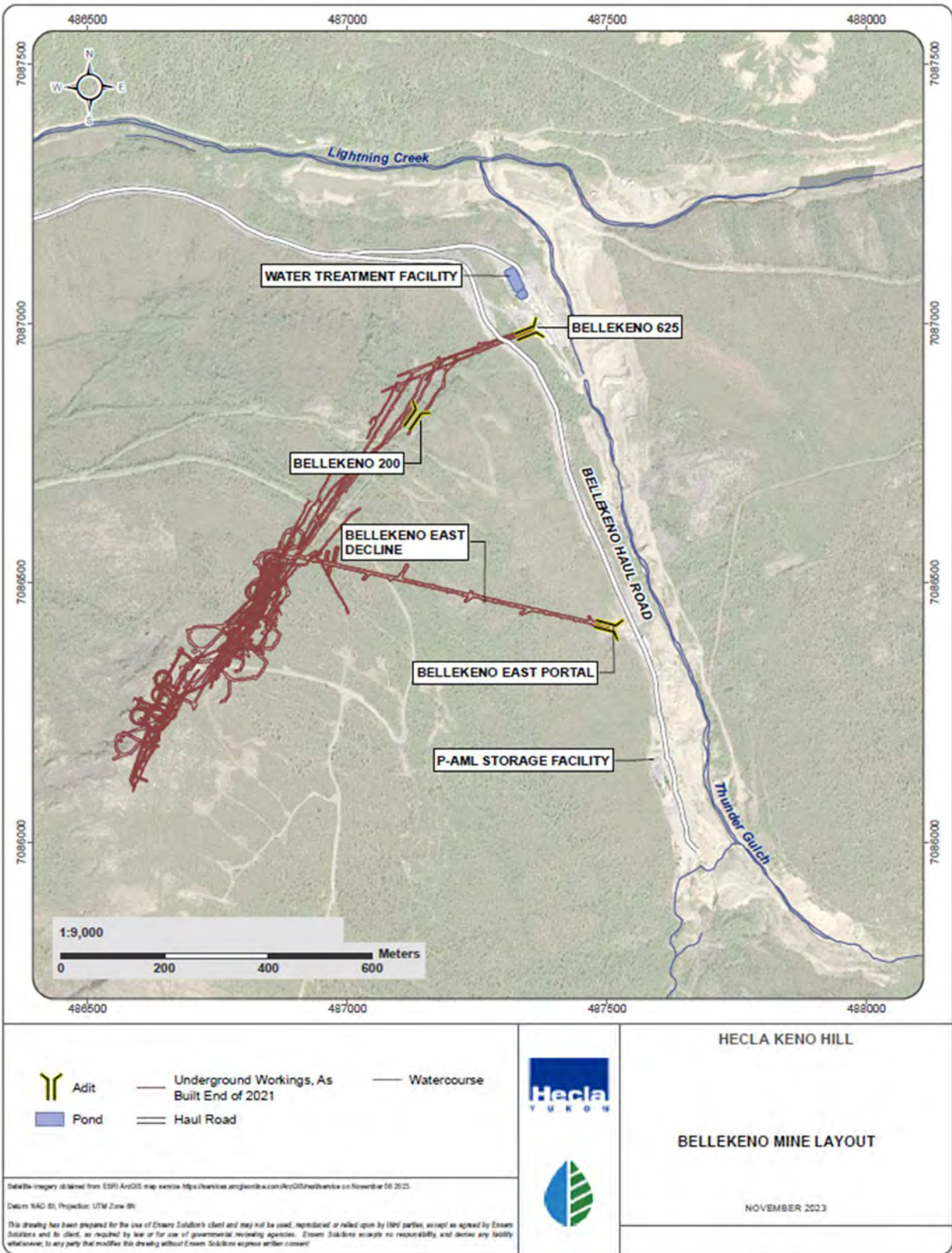

Figure 15-2 – Bellekeno Site Layout.

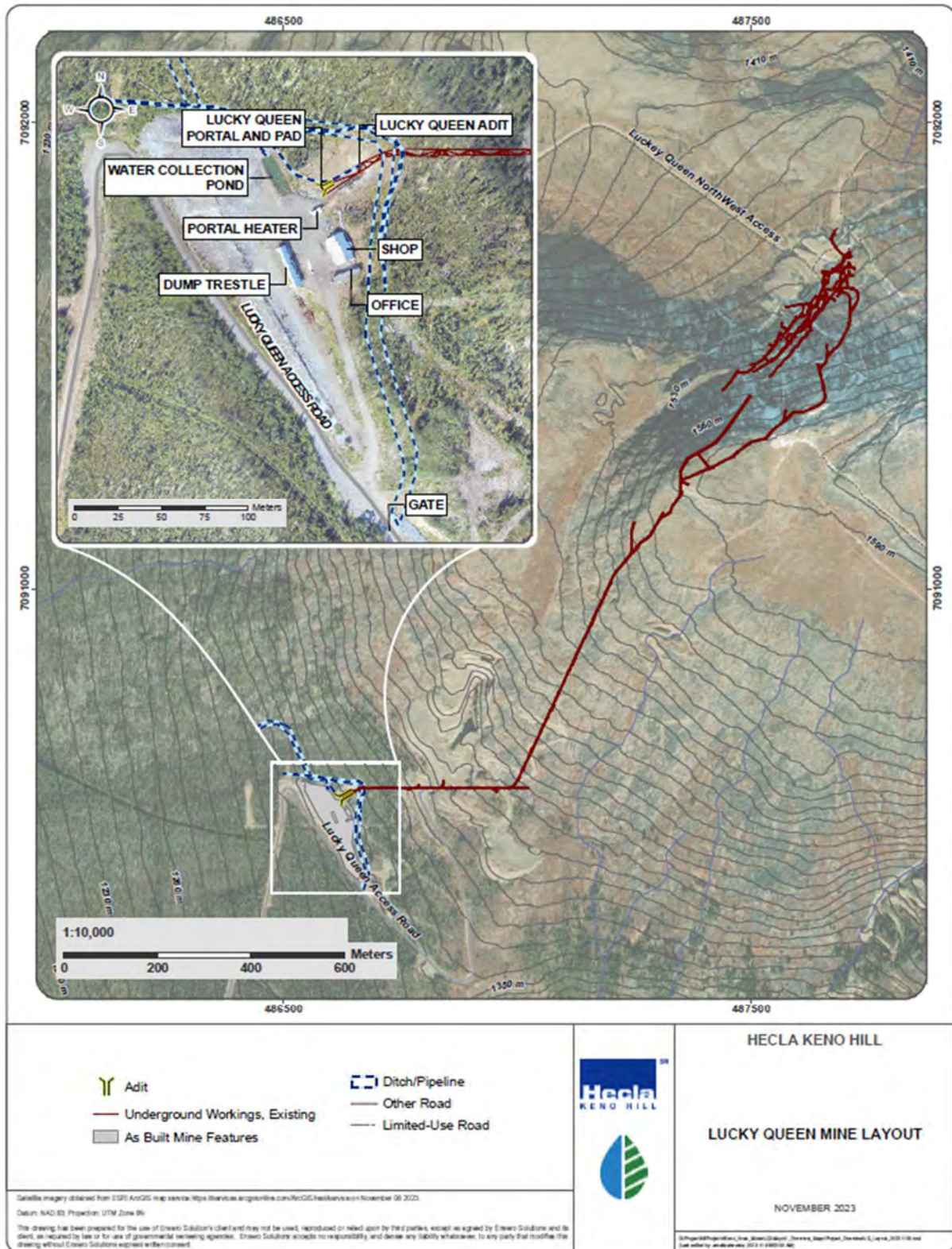

Figure 15-3 – Lucky Queen Site Layout.

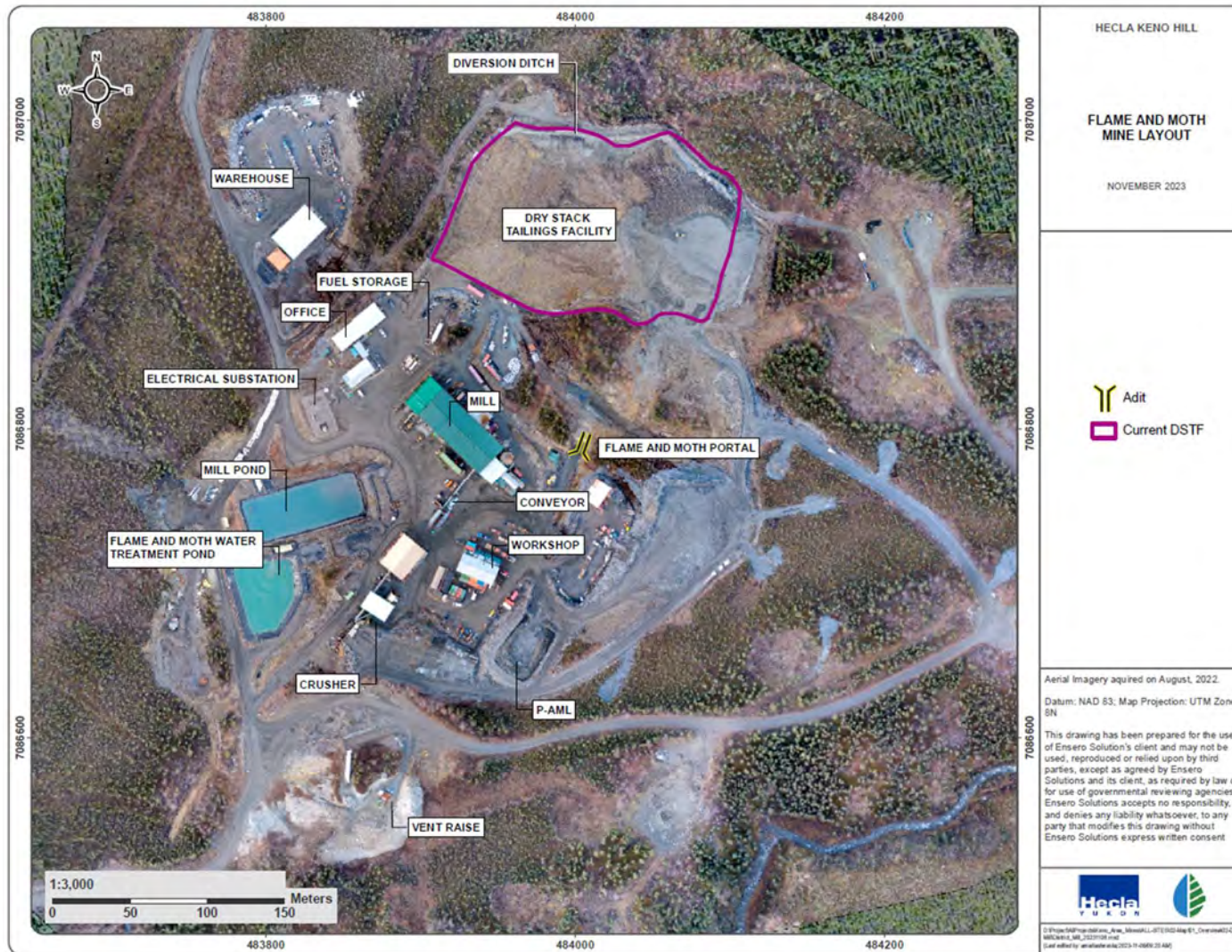

Figure 15-4 – Flame and Moth Site Layout.



Figure 15-5 – Onek Site Layout.



Figure 15-6 – Bermingham Site Layout.

15.5 WATER MANAGEMENT

15.5.1 MINE WATER

15.5.1.1 BELLEKENO

The Bellekeno Mine dewatering pump was halted on October 15, 2021, at the completion of planned mining, and the mine workings have been allowed to flood. The mine was put into temporary closure on December 15, 2021.

Currently, mine water within the Bellekeno Mine has risen to the level where it is reporting to the water treatment plant (WTP) and treatment ponds. The Bellekeno 625 adit began producing water on March 22, 2023, with water reaching the treatment plant. Discharge from the treatment ponds to the environment began on May 16, 2023.

15.5.1.2 LUCKY QUEEN

The new workings at Lucky Queen will not intersect the historical workings and will be above the current groundwater table, as understood at present. However, the new workings will connect with the 500-level adit, and, therefore, any water from this new area will be allowed to mix with water from the historical area. The Water Licence will require an amendment to commence mining at Lucky Queen.

There have been no mining or development activities at Lucky Queen since 2014. The Lucky Queen 500 level drift is currently draining groundwater at a rate of approximately 1 L/s which is directed to an unlined settling pond located outside the portal. This water is predominantly clean groundwater that does not require treatment and meets direct effluent quality standards.

15.5.1.3 FLAME AND MOTH

The majority of the Flame and Moth mine workings are expected to be below the water table; therefore, development of the Flame and Moth mine requires continual dewatering through the Flame and Moth adit. However, the portal has been developed approximately 20 m above the water table so that there should be no long-term discharge from the site.

Hydrogeologic studies and water balance estimates indicate a potential adit discharge during the production of 2,912 m³/day (33 L/s) when the mine reaches its deepest levels. Water Licence QZ18-044 authorizes the Flame and Moth mine to discharge up to 3,024 m³/d (35 L/s).

Water quality encountered in the underground workings is generally compliant except for some metals (current groundwater wells show some iron and zinc), and with elevated levels of ammonia and total suspended solids from underground mining activities.

Water that is dewatered from the proposed workings is pumped to the surface and directed to the water treatment circuit located in the mill facility. Since August 2018 there has been effluent discharged from the water treatment system to Lightning Creek, with effluent flows not exceeding 20 L/s.

15.5.1.4 ONEK

There have been no mining or development activities at Onek. No current dewatering is occurring at Onek.

15.5.1.5 BIRMINGHAM

The new underground workings at Birmingham will not be connected to the historical underground workings. The Birmingham requires continual dewatering through the New Birmingham Portal, with discharge flows typically ranging between 3.0 and 11.0 L/s. The WTP was designed to accommodate a maximum flow of 14 L/s (Alexco, 2021b). Water Licence QZ18-044 authorizes the Birmingham to discharge up to 1,200 m³/d, or the equivalent of 13.9 L/s.

Management of mine inflows at Birmingham is via underground sumps and pumps. Water that is dewatered from the workings is pumped to the surface and directed to the water treatment plant installed near the portal.

Water is treated to meet the effluent quality standards before being discharged to the ground. If excess water accumulates in either of the reactive rock storage areas (P-AML WRSF or the temporary ore/P-AML pad), the water is collected and transported to the water treatment plant.

The New Birmingham WTP discharges to the ground in the upper No Cash Creek catchment.

15.5.2 WATER TREATMENT

15.5.2.1 Bellekeno 625 Existing Water Treatment Facility

Adit drainages from Bellekeno have neutral pH levels but elevated total zinc concentrations. The Bellekeno 625 Water Treatment Facility (WTF, Figure 15-2) is in operation and is effective in treating Bellekeno mine water to remove metals and ammonia prior to discharge. Treatment for metals is likely

to continue over the long term, and these costs are included in the approved Reclamation and Closure Plan (RCP) for the Bellekeno.

The conventional WTP at Bellekeno 625 is designed to treat and discharge a maximum flow rate of 10 L/s. The mine water reports to a circular rapid mix tank where it is mixed with lime slurry and, if required, a coagulant. From the rapid mix tank, water passes into the first lined settling pond (Pond 1), where the majority of total suspended solids (TSS) and metal hydroxide flocculants settle to the bottom of the pond in the form of a sludge. Treated mine water from Pond 1 decants into Pond 2, which allows for additional settling prior to being discharged.

In 2022, dissolved organic carbon (DOC), in the form of molasses, was introduced into the mine workings to facilitate microbe growth and fuel in situ treatment.

Once treatment is established underground, the setting ponds will be converted to a passive treatment system (bioreactor) for treatment of long-term adit drainage and the mine pool will be treated in situ.

Sludge from the Bellekeno 625 WTF has been disposed of into a cell on the surface of the Valley Tailings as authorized under QML-0009. The sludge from Bellekeno 625 that is stored in the Valley Tailings cell is kept separate from the sludge generated at the other treatment facilities. The sludge containment cells are not lined in order to allow water to exfiltrate from the cells.

15.5.2.2 Lucky Queen

There is currently no water use license for Lucky Queen so there are no effluent water quality requirements. Hecla currently monitors the drainage from the 500 level adit. Surface water diversion infrastructure (berms, ditches) will be maintained as appropriate to manage runoff and limit erosion.

15.5.2.3 Flame and Moth

The Flame and Moth underground portal is adjacent to the mill. There are two water management ponds at the mill, one for water treatment effluent and the other for processing water.

15.5.2.3.1 Flame and Moth Pond

The Flame and Moth Pond is located adjacent to the mill pond and serves as a final polishing step for effluent from the water treatment plant. This pond can treat all the water pumped from the Flame and Moth portal. The clarifier overflow water from inside the mill building gravity flows via a high-density 152 mm HDPE insulated pipe into the Flame and Moth Pond. The water is then pumped from the pond

to either the Lightning Creek or Christal Creek discharge points. Discharge into Christal Creek reports to ground, while discharge into Lightning Creek is into surface water.

The Flame and Moth Pond was constructed with an engineered fill embankment.

15.5.2.3.2 Mill Pond

The mill process pond is located downgradient from the mill building. It is used to collect the seepage and drainage from around the mill, the mill dewatering circuits, and the Dry Stack Tailings Facility (DSTF). The pond contains and manages the process water balance required for the milling operation.

Thickener overflow water from inside the mill building gravity flows via a high-density polyethylene (HDPE) insulated pipe into the mill process pond. Sludge that accumulates in the mill process water pond is dredged into filtering geotextile sludge bags within a lined area and hauled underground for disposal when dried.

Process makeup water is pumped from the pond to a 7 m diameter by 7 m high process water storage tank for makeup and recycling in the milling process. The mill process pond is 32 by 79 meters in dimension with a total design capacity of 4,340 m³ based on a 0.4 m freeboard.

Studies are underway to determine if the DSTF can accommodate the inclusion of sludge from the Flame and Moth WTP. If positive, the results will be reported in updated Tailings Management Plans.

15.5.2.4 Onek

Surface water diversion infrastructure (berms, ditches) will be maintained as appropriate to manage surface runoff from entering the decline and limit erosion on site.

15.5.2.5 Bermingham

A conventional water treatment plant using lime addition for metals removal and breakpoint chlorination for ammonia treatment is located adjacent to the Bermingham portal. The mine effluent is pumped from the underground to a reactor tank on the clarifier. The underflow sludge reports to geotextile bags where it is filtered. Flow from the geotextile bags reports to the site's water treatment pond (Figure 15-6). Overflow water from the clarifier is directed to the settling pond. Decant from the settling pond gravity flows through a pipe in the access road and discharges into a settling box and cascades down a rip rap face.

The water chemistry at Bermingham is reviewed regularly to assess long-term water chemistry. Dissolved arsenic concentrations have been consistently below discharge limits in 2022 and are not expected to increase in the long term.

15.5.3 MILL WATER SUPPLY

The majority of the water used in the mill is recycled from one of two water management ponds, Flame and Moth Pond and Mill Pond (Figure 15-4) and is supplied primarily via a submersible pump. The Flame and Moth Pond is permitted to discharge and has appropriate environmental monitoring points.

The details on both ponds are provided in Subsection 15.5.2.3.

The mill water supply is used for processing stream dilution as well as by the plant clean-up hosing stations. Filtered process water is used to supply gland service water for all centrifugal water and slurry pumps in the plant.

15.5.4 RECEIVING ENVIRONMENT

The site is permitted to discharge water from both the Flame and Moth Pond and from the different mines. The Water Licence has varying standards for discharge water chemistry depending on the receiving environment. There is a substantial network of environmental monitoring stations, combined with many years of data and water modeling that shows that operations are not constrained by the net positive water balance, although water must be carefully managed across the site. Details are documented in the issued Water Licence QZ18-044. An adaptive management plan has also been designed to guide responses to unforeseen or contingency events regarding the water quality in the receiving environment.

15.6 WASTE ROCK MANAGEMENT

Studies conducted throughout KHM provide a detailed foundation for understanding the weathering behavior or 'geoenvironmental' characterization of rock in Keno Hill. These studies were used to derive a classification system for waste rock management and inform the Waste Rock Management Plan required by the Quartz Mining Licence QML-0009. All waste rock brought to the surface is classified as Non-Acid Metal Leaching (N-AML) or Potentially-Acid Metal Leaching (P-AML) based on field screening criteria developed for the individual deposits as described in the Waste Rock Management Plan (Alexco, 2022b). Geochemical screening criteria are defined for each deposit, and proportions of P-AML and N-AML material by rock type are estimated to plan materials handling and meet license conditions for the proposed development activities.

Most of the waste rock excavated is expected to be N-AML. Waste rock classified as N-AML will be stored in designated locations at each of the mine sites.

P-AML waste rock (mainly pyrite-rich graphitic schist) is categorized as waste rock and mineralized waste rock of no economic interest with an increased likelihood of acidic or metal leaching. P-AML is stored in designated P-AML waste rock storage facilities or underground as a cemented backfill within excavated production zones. Any water that enters a P-AML waste rock storage facility is collected and treated. Additionally, monitoring the upgrade and downgrade of each P-AML facility is done as part of ongoing site monitoring.

Table 15-1 provides a summary of the waste rock stockpile permitted limits. These permit limits are consistent with the current Water Licence QZ18-044.

Table 15-1 – Waste Rock Storage by Deposit.

Stockpiles		Material Type	Permit Limit (tonnes)
Waste	Flame and Moth	P-AML	12,000
		N-AML	125,000
	Birmingham	P-AML	16,000
		N-AML	190,000

15.6.1 BELLEKENO WASTE ROCK STORAGE FACILITIES AND DISPOSAL AREAS

15.6.1.1 P-AML Waste Rock Storage Facilities

P-AML waste rock previously mined from the Bellekeno mine was placed in a lined temporary Waste Rock Storage Facility (WRSF) located south of the Bellekeno East portal (Figure 15-2). The facility was designed according to the approved generic design (EBA, 2008). During the temporary closure of Bellekeno between Q3 2013 and Q4 2020, the P-AML waste rock stored was transported underground. The temporary WRSF liner was removed and placed underground in 2021. Recontouring and revegetation are taking place with appropriate growth media and seed mixes.

15.6.1.2 N-AML Waste Rock Disposal Area

A Waste Rock Disposal Area (WRDA) was proposed to be constructed along the northeast flank of Sourdough Hill, northwest of the current Bellekeno 625 waste rock storage areas. In 2020, dewatering commenced in Q2, and the mine production resumed in Q4. Mine production ceased in Q4 2021. The Bellekeno WRDA has not been constructed because most of the N-AML waste rock generated from the

Bellekeno mine between Q4 2020 and Q4 2021 has been used for road construction material with a lesser amount for underground backfill. The Bellekeno mine is not included in the current Life of Mine (LOM) plan, and therefore there is no scheduled requirement for the construction of a Bellekeno WRDA.

15.6.1.3 Bellekeno 625 Waste Rock Dump

The Bellekeno 625 waste rock dump (Figure 15-2) is a historic facility that is included in this Reclamation and Closure Plan (RCP) under the designation of the Bellekeno Production Unit. Reclamation and closure of the Bellekeno 625 WRDA will include cleanup of equipment on the top surface of the WRDA, pulling back the crests with an excavator followed by scarification and revegetation of the flat surface of the WRDA. Long-term road access remains for pickup traffic to the Bellekeno 625 adit given it drains and inspections are required during the post-closure monitoring and maintenance period.

15.6.2 LUCKY QUEEN WASTE ROCK STORAGE AND DISPOSAL AREAS

15.6.2.1 P-AML Waste Rock Storage Facilities

A lined temporary P-AML storage facility is planned to be constructed near the portal. This will be used during the initial development stages. P-AML rock stored within the temporary facility will be moved back underground as a backfill as the mine transitions into production. All P-AML waste rock will be re-handled back underground prior to closure. The mine plans for Lucky Queen are still preliminary and it should be noted that Lucky Queen does not have the required water license to begin development.

15.6.2.2 N-AML Waste Rock Disposal Area

N-AML will be used for general construction and access road repairs and surface capping or placed into the onsite N-AML WRDA. N-AML material may also be placed underground as mine backfill, as required. The existing disturbance at Lucky Queen N-AML WRDA will be recontoured by pulling the crests back with an excavator followed by scarification and revegetation of the flat surface of the WRDA.

15.6.2.3 Lucky Queen Historic Waste Rock Dumps

Terrestrial reclamation of historic liabilities at Lucky Queen is currently under the scope of the District Closure Plan.

15.6.3 FLAME AND MOTH WASTE ROCK STORAGE AND DISPOSAL AREAS

15.6.3.1 Flame and Moth P-AML Waste Rock Storage Facilities

A lined temporary P-AML storage facility has been constructed near the portal entrance (up to 16,000 tonnes) and is shown in Figure 15-4. This was used during the initial development which has been completed. The current plan enables all P-AML development rock to remain underground, and the P-AML rock stored within the temporary facility will be moved back underground as a backfill. All P-AML waste rock will be re-handled back underground prior to closure.

15.6.3.2 Flame and Moth N-AML Waste Rock Storage Facilities

A N-AML waste rock disposal area will not be built for Flame and Moth as the rock will either be used for construction or used as a backfill. N-AML materials may be used for the construction of portal pad and laydown area, expanded coarse ore stockpile, mill yard expansion, new haul road to crusher, and construction of the toe berm and base layer for DSTF expansion.

15.6.4 ONEK WASTE ROCK STORAGE FACILITIES AND DISPOSAL AREAS

15.6.4.1 P-AML Waste Rock Storage Facilities

The Onek deposit is not currently in the Keno Hill LOM plan so no Onek P-AML waste dumps are planned.

15.6.4.2 N-AML Waste Rock Disposal Area

The Onek deposit is not currently in the Keno Hill LOM plan so no Onek N-AML WRDA is planned.

15.6.4.3 Onek Historic Waste Rock Dumps

Terrestrial reclamation of historic liabilities at Onek is currently under the scope of the District Closure Plan. A P-AML WRSF was constructed on the historic Onek waste rock dump to the north of the Onek historic open pit (Figure 15-5) for advanced exploration and production at Bellekeno. Although constructed, no P-AML rock has been brought to the surface and stored from the development of the

Onek decline. N-AML Development rock from Onek was used for the construction of the portal area laydown yard and haul road switchbacks.

15.6.5 BIRMINGHAM WASTE ROCK STORAGE/DISPOSAL AREAS

Birmingham P-AML and N-AML waste rock storage facilities are indicated in Figure 15-6.

15.6.5.1 Birmingham P-AML Waste Rock Storage Facilities

A temporary P-AML storage facility has been constructed on the historic Birmingham waste rock dump. This and a secondary P-AML WRSF have been used during the initial development. Currently, the P-AML rock is used for underground backfill. The P-AML rock stored within the temporary facility will also be moved back underground when it can be used for the backfill. Thus, all P-AML waste rock will be re-handled back underground prior to closure.

15.6.5.2 Birmingham N-AML Waste Rock Storage Facilities

An N-AML waste rock from the Birmingham (Figure 15-6) has been used for the construction of portal pads, laydown areas, and roads at the Birmingham as is allowed by the Water Licence QZ18-044.

15.7 TAILINGS

Hecla employs Dry Stack Tailings technology for the management and long-term storage of tailings.

15.7.1 BACKGROUND

In June 2023 Tetra Tech issued for review a Tailing Management Plan (TMP) for Dry Stack Tailings Facility (DSTF). Prior to this, the following engineering design work has been completed (Tetra Tech, 2023):

- Preliminary design for Phase 1 of the DSTF completed between 2008 and 2010 (EBA 2008, 2010a, and 2010b).
- Detailed Phase 1 design completed in 2011 (EBA 2011).
- Phase 1b design completed in 2013 (EBA 2013) as an expansion to Phase 1 to accommodate the permitted tailings volume.

- Preliminary design for Phase 2 of the DSTF completed between 2013 and 2015 (EBA 2013 and Tetra Tech 2015).

Construction and operation of the Phase 1 area have generally progressed per the 2011 detailed design. The changes in the mine planning led to the entire Phase 1 footprint not being constructed. An area included in the footprint immediately north of the mill is now used as a fuel storage area, turnaround, and laydown area.

Monitoring instrumentation was installed during the design and construction of Phase 1, consisting of ground temperature cables (GTCs), slope indicators (SIs), and one standpipe piezometer. Data was collected over the years since installations and the performance of Phase 1 to date has been considered in the design of Phase 2.

The tailings have a low potential for acid rock drainage and metal leaching (Ensero, 2020). While there is some variability in neutralizing potential (NP) between tailings sourced from different areas of the mine site, the bulk NP of the tailings mix is sufficiently high that long-term acid generation is not anticipated.

The composition of the tailings is subject to the milling and filtering processes; however, the particle size distribution of the tailings is typically consistent.

15.7.2 OVERVIEW

The DSTF Phase 2 expansion is approved and included in the amended QML-0009 Revision 7 and Water Licence QZ18-044. These licenses allow for up to 907,000 t of dewatered tailings to be placed at the DSTF.

The existing DSTF presently holds a volume of 223,000 t, or 106,000 m³, and covers an area of approximately 2.4 hectares. The ultimate proposed DSTF capacity is approximately 881,000 t, or 385,000 m³, will cover an area of 5.5 hectares, and is designed to provide for storage and confinement of the tailings. The DSTF footprint is shown in Figure 15-7.

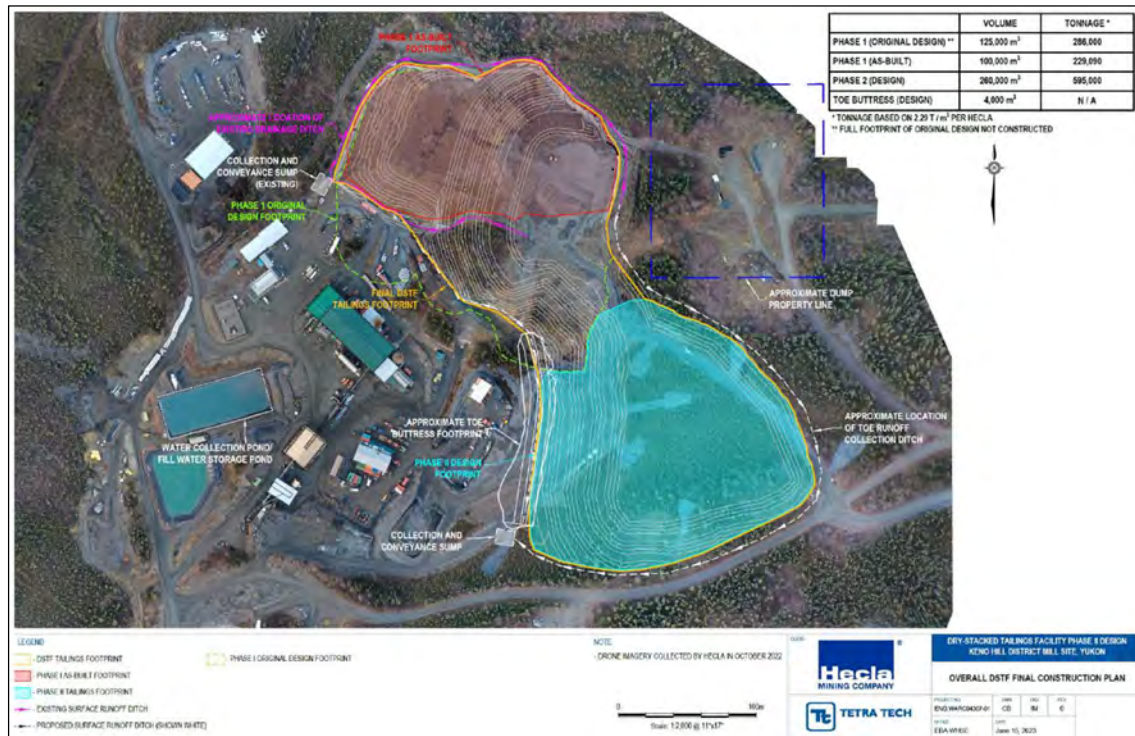

Figure 15-7 – Overall DSTF Plan.

The Phase 2 expansion is located immediately south and southwest of the existing Phase 1 and adjacent to the mill. The area is mostly undeveloped and undisturbed, except for a waste rock storage area along the western edge of the footprint, and existing roadways along the footprint perimeters. Immediately north and northwest of Phase 2 is the Keno City waste dump and access road, respectively.

The DSTF is lined and any surface runoff entering the DSTF area is managed through the outer diversion berms, runoff collection ditches, and the water collection pond. The water collection pond was excavated into the existing ground and lined with an HDPE geomembrane liner. The pond capacity is 3,500 m³.

Surface water within the DSTF is managed with the construction of the drainage blanket and ensuring the tailings stack is graded to reduce surface erosion and direct surface water to areas that drain away from the facility.

On the North side of Phase 1, the drainage system existed from previous years. In the fall of 2023, Phase 1b foundation, lining, toe buttress, and drainage were constructed to allow for designed tailings placement in 2023 and 2024. The toe buttress has a drainage system to allow for proper drainage at the toe of the South side of DSTF Phase 1.

Site preparation and foundation requirements, as well as all other conditions regarding placement and compaction of the tailings, are detailed in the DSTF Operation, Maintenance, and Surveillance (OMS) manual, which forms part of the DSTF Construction and Operation Plan.

The tailings are deposited off a conveyor stacker outside the mill building. According to the TMP, approximately 60% of tailings produced will be placed in the DSTF, and the remaining 40% will be placed underground as backfill. Dewatered tailings for the DSTF storage are hauled from the tailings stockpile outside of the mill building to the DSTF and mechanically spread and compacted in 300 mm-high lifts to form a stacked tailings deposit.

The facility is designed and managed to meet both operational and closure requirements, with a minimum long-term liability and no long-term water treatment requirement. The experience on the existing DSTF supports that with the following performance indicators:

1. The moisture content of the filtered and stacked tailings is lower than the design, resulting in lower makeup water requirements and no discharge of mill water.
2. The metal content of the pore water is lower than initially estimated (~ 2 mg/L vs. 20 mg/L).
3. Humidity cell tests on Bellekeno tailings in the DSTF confirm there is no concern for acid or metal generation.
4. Progressive reclamation has been successfully implemented to date.
5. No pore water has been measured or observed in the DSTF monitoring well installed within the DSTF.
6. Compaction results have met design specifications.
7. Previously observed sluffing on the toe of the DSTF has been repaired, and the sinkholes have been excavated and repacked.
8. Ground temperature and slope indicator readings indicate no thawing of underlying permafrost or movement has occurred to date.

Geochemical characterization has been completed on tailings samples to date and continues during operation, according to the site TMP. Both laboratory and field-testing work shows that the tailings from Bellekeno are non-acid generating. Geochemical testing on tailings from Bermingham and Flame and Moth shows that they are geochemically similar to the already licensed tailings and that no additional measures are required to control metal leaching.

DSTF Phase 2 construction is scheduled to start in summer 2024. The design is currently being revised to incorporate comments received from the Yukon Government. Design revisions include revisions to the seismic criteria and re-evaluation of geotechnical design under updated criteria.

The current permit limits for the Dry Stack Tailings Facility and the Waste Rock Dump Facility are insufficient to cover the planned waste rock and tailings produced over the LOM. Permitting studies are underway and a reasonable timeframe has been identified in the LOM to obtain appropriate permits to establish additional facilities for tailings and waste rock dumps.

15.7.3 CLOSURE

Progressive reclamation has already begun on the DSTF with final slopes being re-contoured and revegetated with a soil cover. The evapo-transpirative cover serving as a growth medium for revegetation is progressively placed as areas of the DSTF fill. When the ultimate capacity of the DSTF is reached, closure and decommissioning will include finishing placement of the evapo-transpirative cover, recontouring the slope as necessary, and ensuring that revegetation is occurring.

16. MARKET STUDIES

16.1 MARKET ANALYSIS

16.1.1 OVERVIEW

Global mined zinc output is approximately 13 million metric tons metal per year, contained in approximately 25 million metric tons of zinc concentrate. Global zinc smelting capacity is approximately 14 million metric tons zinc metal per year and includes 1.5 to 1.8 million metric tons of capacity to refine zinc secondary by-products into metal.

Global mined lead output is only approximately 4.6 million metric tons metal per year, contained in approximately 8 million metric tons of concentrates. Global lead smelting capacity is significantly higher at 13 million metric tons lead metal and also includes the capability to produce approximately 8 million metric tons lead metal from scrap and residues.

Hecla produces approximately 65,000 metric tonnes zinc and 54,000 metric tonnes lead metal, 18.0 Moz Silver and 130 koz Au in concentrates annually at its four mines in North America. Hecla's total output comprises less than 1% of both global zinc mine capacity and global lead mine capacity. Because Hecla's concentrate products also contain significant amounts of payable gold and silver, they are sought after by smelters who capture additional value from recovering precious metals through processing and refining zinc and silver concentrates. The current market for Hecla concentrate products is both very liquid and very strong, globally. Hecla's primary customer base operates in Korea, Japan, Canada, and China. Its concentrate products have also been exported to and processed in Mexico, Belgium, Italy, England, Germany, and the Netherlands.

Global silver supply is approximately 1 billion ounces with mine production accounting for around 80% of silver supply. The majority of silver produced is as a by-product of lead, zinc, copper, and gold mines. According to the Silver Institute, lead-zinc mines are the biggest contributors to global silver supply, accounting for about 32% of silver mine production in 2020. Mexico, China, and Peru produce 50% of world's silver, while the Canada accounts for only 1% of world silver production.

Silver demand is primarily composed of Industrial demand, which accounts for 50% of total silver demand of 1 billion ounces. Investment demand (physical and exchange traded products) and jewelry and silverware account for 25% share each respectively. Silver has the highest electrical conductivity of all metals and this property positions silver as a unique metal for multitude of uses in electronic circuitry in automotive and electronics. Silver's use in photovoltaic cells has also seen a rapid expansion in the past 5 years and is expected to be one of the key growth areas in green energy.

Gold supply is approximately 165 Moz, with mine production contributing 75% of gold supply and recycling accounting for the remaining 25%. In terms of gold demand, jewelry fabrication accounts for approximately 55% of total demand while Investment in physical bars, coins and Exchange Traded Funds

is at 25% of overall demand. Gold’s use in technology applications was around 11 Moz, or 8% of total demand in 2021, according to the World Gold Council. Accommodative fiscal and monetary policies globally due to the COVID-19 lent support to investment demand for gold in 2020 as gold prices reached record levels in 2020.

16.1.2 COMMODITY PRICE PROJECTIONS

The principal commodities of Keno Hill are freely traded at prices that are widely known, so that prospects for sale of any production are virtually assured. Metal prices used in the estimation of Mineral Resources and Mineral Reserves is determined by Hecla’s corporate office in Coeur d’Alene, Idaho, USA. Keno Hill Mineral Resources are estimated using the prices shown in Table 16-1 , while Keno Hill Mineral Reserves are estimated using the prices shown in Table 16-2. The difference in prices is the result of a longer historical period used as the basis for Mineral Resource Estimation.

Table 16-1 – Mineral Resource Metal Prices – 2023.

Commodity	Units	2023
Ag	USD/oz Ag	\$21.00
Au	USD/oz Au	\$1,750
Pb	USD/lb Pb	\$1.15
Zn	USD/lb Zn	\$1.35

Table 16-2 – Mineral Reserve Metal Prices – 2023.

Commodity	Units	2023
Ag	USD/oz Ag	\$17.00
Au	USD/oz Au	\$1,650
Pb	USD/lb Pb	\$0.90
Zn	USD/lb Zn	\$1.15

The Mineral Reserve metal prices were established mid-year 2023 based on the following:

- Hecla’s historic price decks for year-end 2022 Mineral Reserves and Resources, 2024 Long-Range Plans and 2023 budgets.
- Bloomberg Historical prices from June 26, 2023.
- Future prices from Consensus Economics from June 26, 2023.
- Wood Mackenzie Short Term Outlook reports for July 2023.
- Year-end 2022 Mineral Reserve metal price for selected peer and other companies.

The Mining Plus QP is of the opinion that the Mineral Reserve prices for silver and gold are moderately conservative when compared against third-party economics firm’s long-term consensus pricing. The zinc and lead price are near the mean when compared against third-party economics firm’s long-term consensus pricing.

Table 16-3 shows the realized metal prices Hecla has received for sales of its products over its two-year operating history.

Table 16-3 – Hecla Historical Average Realized Metal Prices – Keno Hill Mine.

Commodity	Units	2022	2023	Two Year Average
Ag	USD/oz Ag	\$21.11	\$23.46	\$22.29
Pb	USD/lb Pb	\$0.95	\$0.96	\$0.95
Zn	USD/lb Zn	\$1.61	\$1.14	\$1.37

The economic analysis performed on the 11-year Mineral Reserve LOM plan assumes an average silver price of \$22.00/oz, lead price of \$0.95/lb and a zinc price of \$1.15/lb based upon analysis of December 11, 2023 consensus metal price forecasts by Consensus Economics Inc. The recovered gold in concentrate is not considered payable under the current smelter terms and has not been included in the economic analysis. Based on macroeconomic trends and end of year 2023 financial institution consensus pricing, the Mining Plus mining QP is of the opinion that Hecla’s realized metal pricing will align with the TRS economic assumptions with the potential for short-term upside for silver through the end of 2025.

Please refer to the note regarding forward-looking information at the front of this Report.

16.2 CONTRACTS

16.2.1 CONCENTRATE SALES

The silver-lead concentrate shall be barged weekly from the Port of Skagway, Alaska to the Port of Seattle or the Port of Tacoma, Washington. From Washington it is shipped and distributed to smelters in Asia.

Zinc concentrate is shipped to Greens Creek, Alaska where it’s blended with Hecla’s Greens Creek Mine zinc precious metals concentrate and sent to markets in Asia and Canada.

The long-term indicative concentrate sales terms are shown in Table 16-4 and Table 16-5.

Table 16-4 – Long Term Silver-Lead Concentrate Sales Terms.

Metallic Payables for Each Dry Metric Tonne		
Metal	Payables	Subject to Minimum Deduction
Silver	95%	50 g/dmt
Gold	95%	1 g/dmt
Lead	95%	3 units
Zinc	Not Payable	
TC, RC, Costs for Freight		
Silver RC	USD \$0.65/oz	
Gold RC	USD \$25.00/oz	
Concentrate TC	USD \$55 per dmt	
Freight	USD \$400 per wmt	

Table 16-5 – Long Term Zinc Concentrate Sales Terms.

Metallic Payables for Each Dry Metric Tonne		
Metal	Payables	Subject to Minimum Deduction
Silver	70%	after a 3 oz deduction
Lead Spot	Not Payable	
Zinc BM	85%	8 units
TC, RC, Costs for Freight		
Silver RC	not applicable	
Concentrate TC	USD 320 per dmt	
Freight	USD 250 per wmt	

16.2.2 FORWARD SALES

Hecla uses financially-settled forward contracts to manage the exposure to changes in prices of silver in the concentrate shipments between the time of shipment and final settlement for monthly estimated sales. The silver hedging is typically completed two weeks in advance. The Keno Hill Mine does not hedge gold, lead, or zinc.

16.2.3 OTHER AGREEMENTS

As a condition of the commercial agreement with the Government of Canada under which Alexco acquired the property, future production from the property is subject to a 1.5% NSR royalty payable to the Government of Canada. This royalty is a condition of the ARSA, and it was transferred to Hecla as part of

the Alexco acquisition in September 2022. Approximately CAD 1.2 million of the total CAD 4.0 million has been paid or accrued for as of the date of this Report.

16.2.4 OTHER CONTRACTS

Hecla has entered into a number of contracts to support the operations of the Project including:

- Transportation and shipping of zinc concentrate to a smelter at Greens Creek, Alaska, and silver-lead concentrate overseas.
- Yukon Energy Corp. provides power under contract to various substations and to the Keno Hill District Mill.
- Consumables such as propane, fuel, ground support, and reagents.
- Services including camp and catering services and drilling (exploration).
- Mine contractors are employed for specific mine development projects on occasion.

Hecla has provided Mining Plus with information on all outstanding contracts as well as the information for current pricing terms with smelters.

17. ENVIRONMENTAL STUDIES, PERMITTING, AND PLANS, NEGOTIATIONS, OR AGREEMENTS WITH LOCAL INDIVIDUALS OR GROUPS

Hecla is committed to operating in compliance with all regulations and standards of good practice for environmental, health, and safety. To uphold this commitment Hecla has developed and approved corporate policies for environmental, health and safety practices and has prepared a detailed management plan to facilitate the continuous improvement of its environment and health and safety performance. An Environmental Management System (EMS) is currently in the process of being implemented, completion is expected by the end of 2024.

The mine design meets current standards and the implementation of the proposed environmental and health and safety practices ensures that KHM is prepared to meet future challenges.

The following section describes the updated environmental, permitting, and social contexts of the KHM.

17.1 SITE CONTEXT

The historical operations in the district commenced in the early 1900s. These historical mines are spread out over approximately 200 km², and comprise upwards of 50 mine sites, three tailings disposal areas, and dozens of different shafts, adits, and open pits. Due to the long history of mining, Keno Hill is known as a brownfield site. The current environmental conditions reflect the brownfield conditions as well as the site Care and Maintenance activities to maintain license compliance. Environmental monitoring data and site characterization studies date back to the 1990s.

The Bellekeno, Lucky Queen, Flame and Moth, and Birmingham deposits are all part of the former United Keno Hill Mines (UKHM) claims, which included several historical mines and processing facilities within Keno Hill. The Bellekeno, Lucky Queen and Birmingham sites have historical mine workings, waste rock storage areas, and mine water discharges, whereas the Flame and Moth site only has minor historical surface mine workings and a waste rock storage area that were reclaimed during the construction of the Keno Hill District Mill.

Hecla and its subsidiary, ERDC, have a commercial agreement with the Government of Canada in which Hecla is responsible for the care, maintenance, and closure of the historical mines, with funding from the government and the company to address the historical liabilities. The commercial agreement also allows Hecla to undertake exploration of the AKHM site and undertake active mining. Under this agreement, Hecla is responsible for environmental assessment, permitting, compliance, and costs associated with its ongoing exploration and new mine development activities. Additionally, if a new mine is brought into production including the use of infrastructure associated with a historic mine, terrestrial liabilities (i.e.,

waste rock storage areas and roads) and water-related liabilities located within a designated “Production Unit” become the responsibility of Hecla. At this time, Bellekeno and Flame and Moth have been defined as one combined active Production Unit under the Bellekeno Production Unit. Birmingham Production Unit notice was submitted to CIRNAC and approved November 24, 2023. When commercial ore production occurs at Lucky Queen, then a production unit would need to be declared. That production unit would encompass the Lucky Queen mining area that is reasonably expected to be affected by production-related activities, including production features authorized in required permits and surface and groundwater expected to be affected by the permitted activities. Liability for reclamation and closure of the defined production unit would fall to AKHM.

Hecla, along with territorial, federal, and First Nation governments, is also responsible for developing a district-wide reclamation plan that addresses these historic environmental liabilities arising from past mining activities. Under the agreement, Hecla is indemnified from the historic environmental liabilities. The latest reclamation plan, revision 7, was prepared by Alexco and issued in October 2022. Currently, water treatment is carried out at five locations in Keno Hill (Galkeno 300, Galkeno 900, Silver King, Onek 400, and Valley Tailings), as required by the ERDC’s Water Licence QZ21-012.

Alexco developed a reclamation plan that was used by Hecla to acquire Water Licence QZ21-012 in April 2023. Hecla is working towards implementing this water license and reclamation plan.

17.2 ENVIRONMENTAL AND SOCIO-ECONOMIC SETTING

The property is located within the Yukon Plateau (North) Ecoregion and is characterized by rolling upland areas and wide-open valleys. Vegetation communities include Northern boreal forests along the lower slopes and valley bottoms and open scree slopes above the tree line. Many of the valley bottoms include open peatlands, fens, and meadows. A variety of wildlife, birds, and fish species are present in the area.

Keno Hill falls in the subarctic climate of the Koppen climate classification. The closest current long-term climate record is at the Mayo Airport, which had an average daily temperature of -2.4°C and average annual precipitation of 313.5 mm, with 203.8 mm falling as rain for the 1981 to 2010 period (the public record is updated every 10 years). The wet season occurs in summer/fall with drier winters. Meteorological data have been collected in Keno Hill for three locations: since 2007 at the Calumet weather station as part of the development of the reclamation studies for historic liabilities; since 2011 at the Keno Hill District Mill meteorological station as part of Bellekeno mining operations; and, since 2012 at the Valley Tailings Facility meteorological station. The monthly and annual temperatures are on average colder at the three Keno Hill stations than at Mayo Airport, which is expected given the higher site elevation.

The environmental setting of the site is summarized in Table 17-1. The current environmental conditions reflect the brownfield conditions and recent improvements as a result of Care and Maintenance water treatment upgrades and interim reclamation undertaken by ERDC for the historic liabilities.

Table 17-1 – Keno Hill Mine Setting Summary.

Drainage Region	Stewart River drainage region
Local Catchments	No Cash Creek, Flat Creek, Christal Creek, Lightning Creek
Ecoregion	Yukon Plateau (North)
Study Area Elevation	900-1,350 masl
Vegetation Communities	Northern boreal forests occupy lower slopes and valley bottom; spruce, pine, and alder; grasses and sedges, mosses occupy the forest floor; heavy moss and lichen growth resident as ground cover; understory of shrub willow; open and forest fringe areas of willow and scrub birch, and various flowering plant species.
Wildlife Species	Moose, grizzly and black bear, caribou, beaver, wolf, lynx, marten, wolverine, western tanager, magnolia warbler, white-throated sparrow, bald eagle, furbearers, and small animals. Committee on the Status of Endangered Wildlife in Canada (COSEWIC) listed species include Common Nighthawk (Threatened); Rusty Blackbird and Olive-Sided Flycatcher (Special Concern).
Fish Species	Bering and Beaufort Sea salmonids and freshwater species, including Arctic grayling, Arctic char, lake trout, trout perch, lake whitefish, broad whitefish, burbot, inconnu, Arctic Cisco, Northern pike, slimy sculpin

The KHM is situated in the traditional territory of the First Nation of Na-Cho Nyäk Dun (FNNND). The deposits are located within 5 km of Keno City, which has a population of 20 as of June 2021, and 50 km from the community of Mayo, which has a population of 458 residents as of September 2020. The area has been shaped by mineral development over the past hundred years. Silver and lead ore deposits were discovered on Keno Hill in the early 1900s and the area has since seen fluctuating levels of ongoing quartz and placer mining and exploration. Today the area supports not only mineral development, but also tourism, recreational, and traditional land uses.

The KHM is supplied with electrical power by Yukon Energy Corporation from two hydroelectric plants near Mayo. The Silver Trail Highway runs through the KHM, en route to Keno City, and is the primary access route for the site. This road is a public highway that is maintained by the Government of Yukon.

17.3 PERMITS AND REGULATORY CONTEXT

Mining projects in Yukon require assessment under YESAA, as well as a Quartz Mining Licence (QML) under the Quartz Mining Act (QMA) and a Water Use Licence (WUL) under the Waters Act.

The existing approvals and assessments currently underway for both exploration and mine development activities are summarized in Table 17-2. The table also includes existing approvals under ERDC for the historic liabilities’ care and maintenance, and reclamation plan. A number of environmental and socio-economic studies have been completed for Keno Hill since 2006 in support of the mining permit applications, as well as in support of the reclamation planning being completed by ERDC.

Table 17-2 – Relevant Approvals, Permits, and Licenses.

Authorization Number	Authorization Permit	Effective Date	Expiry Date
YESAA Approvals ¹	Decision Documents and Evaluation Reports for projects #2006-0293, #2006-0157, #2008-0039, #2009-0030, #2011-0315, #2012-0141, #2013-0161, #2017-0086, #2017-0176, #2017-0183, and #2018-0169		
Bellekeno Mine	Authorization to deposit effluent (MDMER)	September 7, 2020	None Stated
Flame & Moth Mine	Authorization to deposit effluent (MDMER)	November 30, 2020	None Stated
QZ18-044	Type A Water Use Licence	July 23, 2020	August 1, 2037
LQ00476	Class 4 Mining Land Use Approval	June 17, 2018	June 16, 2028
QML-009	Quartz Mining Licence	Nov. 27, 2019	Aug. 1, 2037
Permit No: 81-067	Commercial Dump Permit	January 1, 2022	December 31, 2026
Permit No. 81-012 (ERDC)	Commercial Dump Permit	February 9, 2023	December 31, 2027
Permit No: 4202-22-047 Permit No: 4202-22-057	Relocation Permit (small volumes) ²	July 21, 2022	December 31, 2022
		January 18, 2023	December 31, 2023
Permit No. 3448 (Flat Creek Camp)	Sewage Disposal	June 10, 2008	None Stated
Permit No. 3449 (Elsa houses)	Sewage Disposal	June 24, 2010	None Stated
Permit No: YT-556 Permit No. YT 557	Explosives Magazine Permit Detonator Magazine Permit Flame and Moth	June 10, 2020	June 10, 2025
Permit No: YT-558 Permit No. YT-559	Explosives Magazine Permit Detonator Magazine Permit Birmingham	June 29, 2020	June 29, 2025
Permit No. YT-581 UG	Explosives Magazine Permit Flame and Moth	June 16, 2022	June 16, 2027
Permit No. YT-580 UG	Explosives Magazine Permit Birmingham	June 16, 2022	June 16, 2027
60738-1-25.0	Nuclear Substances and Radiation Devices Licence	March 7, 2023	May 31, 2025

Notes:

1. Refer to Table 3-1 – Relevant Assessment and Regulatory Approvals.
2. Renewal is expected to be obtained in 2024.

The Bellekeno, Birmingham, and Flame and Moth mines have all permits and authorizations in place to commence full-scale mine production. Water Licence Application QZ18-044 was submitted to the Yukon Water Board in August 2018 to renew the existing Water Use Licence QZ09-092 to include the Birmingham deposit and extend the license term for a further 17 years to 2037. The new Water Licence QZ18-044 was issued in July 2020 which includes Bellekeno and Flame and Moth as well. To maintain full-scale production for an extended period of time, or to increase production at those deposits, it is likely that modifications to certain permits will be required, including the Quartz Mining Licence (QML-0009), and the Water Licence QZ18-044, in order to increase water discharge amounts/rates, increase the volume or change location of waste rock and tailings storage, or other changes.

Although the QML authorization is also in place for Onek and Lucky Queen, there are currently no plans to bring the Onek deposit into production. A minor amendment to the Water License would be required

to bring Lucky Queen into production. The existing approvals are for the mill throughput of 400 tpd (based upon a 12-month average) and will require additional amendment to the QML to increase the throughput to 550 tpd.

17.4 COMMUNITY AND FIRST NATION RELATIONS SOCIO-ECONOMIC MONITORING

Since Hecla acquired Alexco in 2022, Hecla has been working on a number of programs as a part of the Socio-Economic Monitoring in Keno Hill.

17.4.1 IMPLEMENTATION OF THE KENO HILL CITY SOCIO-ECONOMIC MITIGATION PLAN

AKHM meets regularly with stakeholders and First Nations regarding the ongoing operations as, well as the new development plans for Flame and Moth and Birmingham, presenting detailed information about the operations and seeking expression of concerns. Additional consultation facilitated by the regulators is also part of the formal YESAA and licensing processes. Key socio-economic risks identified for the project include relying on all employee workforce and not contractors for development, including the availability of skilled workforce locally and retainment of the workforce.

17.4.2 FIRST NATIONS RELATIONS

Hecla is party to a Comprehensive Cooperation and Benefits Agreement (CCBA) with the FNNND that recognizes the rights, obligations, and opportunities of the two parties.

17.4.3 COMMUNITY RELATIONS

Keno City is a small community situated at the end of the Silver Trail Highway with a population of approximately 12 permanent residents. Due to the close vicinity of this site to the community of Keno City, noise, dust, and traffic have been high-profile issues at this site and several permit conditions address these concerns. Several specific issues were raised during the YESAA process and have been included in the decision document and Quartz Mining Licence. Mitigation measures that have already been implemented or that are proposed by the company include limiting certain activities (e.g., crusher operations) and types of traffic to the hours of 7 am – 7 pm, constructing a building around the crusher and installation of a sound dampening enclosure around the Flame and Moth ventilation fan.

Dust is closely managed and monitored at the site. The dust monitoring data is compared to the Yukon ambient air quality standards.

There is a network of access roads and haul roads throughout the district. Haul roads have been upgraded between Birmingham and the mill, and a bypass constructed around Keno City to reduce traffic and noise for the residents. Required road upgrades to access the Birmingham portal location were completed between 2018 and 2020 which mainly involved widening, surfacing, and installing berms along Calumet Road.

The local community and First Nations have expressed interest in continued access to recreation and tourism in the area, subsistence harvesting and traditional use, sport and commercial hunting, fishing, and trapping, mineral development, and preservation of historical resources. A Heritage Resource Overview Assessment was completed in 2018, in which no areas of overlapping high heritage values were identified for the project area (Ecofor, 2018). There are processes for the communication of issues and grievances in place.

Throughout 2022, AKHM was in discussions with Keno City residents and the office of the Yukon Government Director of Operations and Programs, Department of Community Services to enable AKHM to provide a household refuse haulage service to a community landfill elsewhere in the Yukon Territory for Keno City residents following the closure of the community's transfer station.

17.5 CLOSURE PLAN AND SECURITY

An updated Reclamation and Closure Plan was approved by the Yukon Government in October 2022 that encompasses all the mining and processing activities in the Keno Hill.

The Keno Hill Reclamation and Closure Plan addresses underground mining activities at the Bellekeno, Flame and Moth and Birmingham deposits, reclamation of existing disturbances at Lucky Queen and Onek, and for each mine all surface support infrastructure and activities, miners' dry area, offices, trailers, and portals.

Some key aspects of the closure plan are listed as below:

- Waste rock storage facilities will be regraded and then scarified. Organic materials may be blended into the surface to promote growth of vegetation. P-AML waste rock will mainly be placed as backfill in the mine or sloped to shed water and then covered with a 0.5 m layer of low permeability borrow material.
- Adits and raises will be sealed to prevent access. Bulkheads will be constructed in some areas to enhance water management activities.

- At the Flame and Moth, Bermingham and Bellekeno mines, in situ treatment measures will be implemented to reduce metal loadings if required. The active treatment systems will be replaced with passive bioreactor systems.
- All buildings and equipment that are not needed for the treatment activities will be removed from the portal areas. Any additional debris will be transferred to the Elsa solid waste disposal facility. The portal areas will be re-contoured and scarified to facilitate re-vegetation.
- Linear disturbances (roads) will be subject to standard decommissioning measures such as removal of culverts, scarification, re-vegetation, and removal of safety berms.
- The Flat Creek camp will be downsized as needed to support ongoing care and maintenance activities in the KHM.
- Buildings and other infrastructure in the mill area will be dismantled and sold for salvage or demolished on site and disposed of in an approved landfill. Concrete footings will be covered with overburden, scarified, and re-vegetated.
- The DSTF will continue to be progressively reclaimed over the life of the facility with recontouring the side slopes to the final design slope angle (3:1) and placing of cover. If monitoring indicates that it is necessary, meteoric water will be directed to a passive biological treatment system for polishing prior to discharge.
- Various monitoring activities will continue until the performance of the closure measures has been verified.

Hecla expects to have a site presence for many years while reclamation of the historical liabilities occurs. Therefore, monitoring of the Bellekeno, Lucky Queen, Flame and Moth, and Bermingham mine areas can be integrated with KHM monitoring programs over the long term. This is expected to improve the efficiency of these ongoing water treatment and monitoring activities.

YG requires financial security in the form of a letter of credit to cover potential liabilities associated with the cost of reclamation and closure. The third-party closure cost estimate is consistent with the plan requirements and closure costing guidance as per the August 2013 Reclamation and Closure Planning for Quartz Mining Projects. AKHM has completed a cost estimate to implement Revision 7 of the Reclamation and Closure Plan for the Keno Hill Mine and the estimated cost to implement the reclamation and closure plan at the End of Mine Life (EOM) is CAD 9,643,943. Following an internal review process, the amount of security currently required by the Yukon Government for the reclamation and closure of the Keno Hill Mine is CAD 9,681,500 which includes any security already held under the Water Act. AKHM was issued a Type A Water Licence (QZ18-044), and the Yukon Water Board also requires AKHM to furnish and maintain financial security with the Yukon Government which includes any security held under the Quartz Mining Act. Following the review of the Reclamation and Closure Plan Revision 6, pursuant to the Waters Act, AKHM has furnished a security of CAD 11,346,433. It is important to note that not all the liabilities included in the cost estimate have yet been realized or created.

Additional closure costs may be incurred if the effectiveness of the current closure concepts cannot be demonstrated. For example, active water treatment may be required at Bellekeno if passive bioreactors

are not capable of meeting the discharge criteria. A full-scale pilot bioreactor has operated successfully at Galkeno 900 to support the long-term water management and treatment assumptions in the closure plan. The ongoing monitoring programs will be critical for ensuring that there is sufficient information available to support final closure plans for these production areas. A pilot scale in situ treatment process has been successfully demonstrated at the Silver King mine.

18. CAPITAL AND OPERATING COSTS

Unless otherwise noted, all dollar amounts are presented in United States (USD) dollars based on a USD:CAD exchange rate of 1.35 and accurate to the 1st of January 2024, and all other measurements are metric values.

This section describes:

- Capital cost estimates, also referred to as Capital Expenditure or CapEx estimates.
- Operating cost estimates, also referred to as Operating Expenditure or OpEx estimates.

The capital cost and operating estimates were generated by Hecla and reviewed in detail and modified where necessary by the respective QP's from Mining Plus Canada (for all components except the process plant, and surface infrastructure) and by Sedgman Canada Ltd. (process plant, and surface infrastructure). The QPs consider the accuracy of the components of the capital cost estimate to be appropriate for an operating mine.

The forecasted capital and operating cost presented in this Technical Report is estimated to have an overall accuracy AACE Class 1 for Bermingham and Flame and Moth, and an AACE Class 3 for the Lucky Queen deposit.

The cost estimate is developed by the mine area and includes the development and production of the Flame and Moth and Bermingham deposits and the re-opening of the Lucky Queen plus the necessary infrastructure for increasing the scale of operations at the Keno Hill Mine.

18.1 CAPITAL COSTS

The capital costs are provided by Hecla and reviewed by Mining Plus Canada. The capital costs accuracy is considered equivalent or better than AACE Class 1 with an expected accuracy range of -3% to -10% on the low side and +3% to +15% on the high side. AACE Class 3 accuracy ranges from -10% to -20% on the low side and +10% to +30% on the high side.

18.1.1 SUMMARY OF CAPITAL COST ESTIMATE

Hecla uses the LOM plan as the planning guide for the KHM. The LOM capital costs total USD 194.85 million and include mine development, mine infrastructure, mobile equipment costs, and processing (Table 18-1). Mining Plus QP is of the opinion that the estimated capital costs for Keno Hill are reasonable.

Capital development is expected to include approximately 16.5 km of capital development up to 2034.

Table 18-1 – Summary of Major Capital Cost Categories Across Keno Hill Mine.

Capital Cost	Units	Total	2024	2025	2026	2027	2028	2029	2030	2031	2032	2033	2034	2035
Drilling	USDMM	23.58	2.36	2.36	2.36	2.36	2.36	2.36	2.36	2.36	2.36	2.36	0.00	0.00
Mine Dev., Rehab., Stripping	USDMM	96.39	18.85	6.89	2.11	17.92	16.58	9.98	5.97	6.21	5.13	4.82	1.93	0.00
Mine Infrastructure	USDMM	11.83	6.62	2.33	0.00	0.38	0.51	1.13	0.12	0.00	0.73	0.00	0.00	0.00
Mobile Equipment	USDMM	38.43	4.35	1.10	2.65	4.50	0.97	2.15	3.22	6.23	5.08	8.18	0.00	0.00
Ore Processing	USDMM	15.88	1.45	3.92	0.50	0.00	0.00	0.00	10.00	0.00	0.00	0.00	0.00	0.00
Reclamation and Closure	USDMM	8.74	0.00	0.00	0.00	0.00	0.00	0.00	0.00	0.00	0.00	0.00	0.00	8.74
Total Capital Costs	USDMM	194.85	33.63	16.60	7.62	25.16	20.41	15.62	21.66	14.80	13.30	15.37	1.93	8.74

18.1.2 MINE CAPITAL EXPENDITURE

The mining capital cost estimate is comprised of sustaining and growth capital and is based on the following information:

- Equipment costs based on equipment expenditures to date, vendor quotations, and validated owner cost sheets.
- Quantity takes-offs from underground development and production designs with a monthly mining schedule.
- Quantity take-offs for materials provided by engineering drawings from capital projects.
- Labor rates provided by Hecla are currently in effect at Keno Hill and updated based on current local market conditions assuming owner mining with the exception of Lucky Queen which will be contractor mining.
- Productivities for mobile equipment, mining processes, and labor based current performance to date and performance estimates provided by other Hecla-owned operations.

Exclusions from the sustaining capital cost estimate include, but are not limited to, the following:

- Study costs to advance KHM engineering.
- Fluctuations in exchange rates.
- All sunk costs prior to the end of December 31st, 2023.
- Project financing and interest charges.
- Escalation during construction and operation
- Operating costs.

18.2 OPERATING COSTS

18.2.1 SUMMARY OF OPERATING COST ESTIMATE

The total operating costs are \$483.3 M over the LOM. This is net of capitalized underground development and milling. Mine, mill, and site G&A (excluding Corporate G&A) operating costs and unit operating costs, are summarized in Table 18-2 and Table 18-3 respectively, and discussed in more detail in the following sections.

Table 18-2 – Life of Mine Direct Operating Cost Summary.

Operating Cost	Units	Total	2024	2025	2026	2027	2028	2029	2030	2031	2032	2033	2034
Mining	USDM	244.15	27.39	21.73	19.41	27.03	21.45	21.91	20.56	20.67	21.48	25.18	17.34
Milling	USDM	88.31	7.58	8.05	8.40	8.49	8.65	8.71	8.72	8.64	8.68	8.69	3.70
G&A	USDM	150.84	14.48	15.39	15.22	15.14	14.13	14.14	14.14	14.01	14.09	14.11	6.01
Total Operating Costs	USDM	483.29	49.46	45.16	43.02	50.65	44.24	44.76	43.41	43.32	44.25	47.97	27.05

Table 18-3 – Life of Mine Unit Operating Cost.

Operating Cost	Units	Total	2024	2025	2026	2027	2028	2029	2030	2031	2032	2033	2034
Mining	USD/t	130.05	215.18	156.01	132.81	152.75	106.84	109.07	102.31	103.84	107.25	125.60	203.18
Milling	USD/t	47.04	59.57	57.80	57.45	47.96	43.08	43.37	43.39	43.38	43.36	43.37	43.37
G&A	USD/t	80.35	113.75	110.49	104.14	85.55	70.37	70.37	70.37	70.37	70.37	70.37	70.37
Total Operating Costs	USD/t	257.43	388.49	324.31	294.40	286.27	220.29	222.81	216.07	217.59	220.98	239.34	316.92

18.2.2 OPERATING COSTS BASIS OF ESTIMATE

The operating cost estimate is based on the following information:

- Labor rates provided by Hecla are currently in effect at Keno Hill and updated based on current local market conditions assuming owner mining with the exception of Lucky Queen which will be contractor mining.
- Productivities for mobile equipment, mining processes, and labor based current performance to date and performance estimates provided by other Hecla-owned operations.

All mill-related infrastructure with the exception of the crusher is planned to operate 24 hours per day, 365 days per year, with less planned maintenance downtime. The crusher is planned to operate 12 hours per day during the day shift only. The mine will operate two 12-hour shifts per day.

The technical report labor cost build-up represents a combination of the first principal estimation and actual remuneration packages for project labor. The workforce varies throughout the years, depending on the production and development schedules. The peak workforce is 243 people, comprising 26 site management roles, 47 mill roles, and 30 on site services, environment, and health and safety. The majority of employees work 2 weeks on, 2 weeks off rotating schedule.

18.2.3 MINE OPERATING COST

The mine operating cost estimate includes equipment operation and maintenance, labor, new materials, explosives, ground support, ventilation, underground air heating, fuel, mine water pumping and treatment, parts, underground definition drilling, and supplies within the following major categories:

- Lateral and vertical development, including ground control.
- Underground services development.
- Production drilling, blasting, load/haul.
- Backfilling.

18.2.4 MILL OPERATING COST

The mill operating costs were developed by Hecla and reviewed and modified by the QP for the process plant (Sedgman Canada Ltd.). The quantities and cost data that form the basis for the mill operating costs include the following sources:

- Current experience with operating the existing mill.
- Metallurgical test work.
- Supplier quotations.

Non-reagent consumables include but are not limited to liners, drive belts, screens, pumps, cyclones, grinding media, filter cloth, electrical supplies, pipes, hoses, fittings, valves, motors, lubricants, fuel, lumber, and steel.

The grinding media uses forged balls and consumption was based on the current mill operation that is envisaged to increase to account for the higher throughput in the current mine plan.

The mill operating costs include the on-site assay lab located in the mill for regular operational samples. An allowance has been included for external assays on mill concentrates.

The annual mill operating cost is estimated at \$8.5 M per year or \$47.0 per milled tonne of ore. The process operating costs commence at the ore stockpile located beside the primary crusher building.

18.2.5 GENERAL AND ADMINISTRATIVE COST

The category of G&A includes the areas of Financial Administration, Site Environmental, Health and Safety, Camp Operations, Site Services, Mine Supervision, Mine Electrical and Mine General. G&A costs are estimated based on various fixed monthly costs as well as variable costs such as camp, equipment operations, electrical and employee travel.

The G&A costs are shown in Table 18-4.

Table 18-4 – General and Administrative Costs.

Cost	Unit Cost (\$/t)	Total Cost (USDM)
Site G&A	83.35	150.84

19. ECONOMIC ANALYSIS

The economic analysis contained in this Technical Report Summary is based on the Keno Hill Probable Mineral Reserves material only, economic assumptions, and capital and operating costs provided by Hecla's technical team and validated by the Mining Plus QP and post-tax financial model QP.

19.1 FORWARD-LOOKING INFORMATION AND CAUTIONARY STATEMENTS

Please refer to the note regarding forward-looking information at the front of this Report.

19.2 METHODOLOGY USED

In the financial analysis, the Discounted Cash Flow (DCF) method was adopted to estimate the project's return based on expected future revenues, costs, and investments. Following the DCF method, the net cash flow for each period was discounted at an annual rate of 5% (unless stated otherwise) to a present value and then added to yield a net present value (NPV).

The DCF model for the project assumes that all figures are expressed in constant dollars or real terms. All monetary figures are expressed in United States dollars (USD) unless otherwise noted. Unless otherwise stated, all costs in this section of the TRS are expressed without allowance for escalation or currency fluctuation. Current Canadian tax regulations were applied within the financial model by Hecla Management with support from Hecla's tax advisors.

The QP's have reviewed the LOM cost estimates and DCF model in sufficient detail to be satisfied that the economic extraction of these Probable Mineral Reserves is justified.

A summary of the key project criteria is provided in the subsequent subsections.

19.3 ECONOMIC CRITERIA

The project value is determined on a pre-tax and after-tax basis at a 5% discount rate with the economic criteria in Table 19-1 and listed below.

Table 19-1 – Economic Criteria Used to Determine Operations Value.

Parameter	Units	Value	
Life of Mine	years	11	
Average Mill Feed over LOM	tonnes/year	170,669	
Mill Recovery (Net)	Silver (Ag)	%	96.0
	Lead (Pb)	%	93.2
	Zinc (Zn)	%	72.0
	Gold (Au)	%	-
Government of Canada NSR Royalty	%	1.5 (to max. CAD 4 M)	
Average Operating Cost	USD/ tonne milled	257.43	

Additionally, the following criteria have been applied:

- Processing between 400 and 550 tonnes per day of mill feed for a total of 1.88 M tonnes over LOM.
- LOM production plan as summarized in Subsection 13.3.
- Total Mineral Reserves shown in Table 12-1.
- Silver-lead and zinc concentrates shipped to the smelter for treatment.
- NSR includes shipping, treatment, and refining costs.
- Revenue recognized at the time of production.

19.3.1 REVENUE

- Metal prices used in the economic analysis are constant USD 22.00/oz Ag, USD 0.95/lb Pb, and USD 1.15/lb Zn.
- Gold is not payable in the current Mineral Reserve calculations. In the current smelter contract gold is payable but no credits were found due to low quality in the concentrate.
- LOM net revenue is USD 1,117.6 million (after royalty and treatment and refining charges).
- Transportation, treatment, and refining charges are estimated at USD 2.65/oz Ag over the LOM.
- Mill process recovery in the Keno Hill LOM 2024 plan is estimated at 92.0% Ag, 88.0% Pb, and 4.0% Zn in the silver-lead concentrate and 68% Zn, 5.2% Pb, and 4.0% Ag in the zinc concentrate.

19.3.2 CAPITAL COSTS

Total LOM capital requirements have been estimated at USD 194.85 million and are described in detail in Section 18.1.1.

Closure costs of USD 8.74 million estimated by Hecla Yukon are included in the analysis at the end of the LOM.

This financial analysis does not include any sunk costs prior to year 1 of the economic analysis.

19.3.3 OPERATING COSTS

The LOM operating costs are shown in Table 19-2. The mining cost per tonne of ore milled is \$130.05 per tonne and processing costs are estimated at \$47.04 per tonne of ore milled. General and administration costs are estimated at \$80.35 per tonne of ore milled for a total operating cost of \$257.43 per tonne of ore milled.

Table 19-2 – Summary of LOM Operating Costs.

Operating Cost	LOM Total Cost (\$ M)	LOM \$/Tonne Milled	LOM \$/oz Ag Payable
Mining	244.15	130.05	4.92
Processing	88.31	47.04	1.78
General and Administration	150.84	80.35	3.04
Total Operating Cost	483.29	257.43	9.73

Note: rounding of cost estimates may result in apparent summation differences when compared to overall unit costs.

19.3.4 TREATMENT, REFINING AND TRANSPORT

The total treatment and refining costs equate to an average of \$36.36 per tonne of ore milled for the life of mine. Transport costs equate to an average of \$33.85 per tonne of ore milled for the life of mine. These are summarized in Table 19-3.

Table 19-3 – Treatment, Refining, and Transport Cost Statistics (Unit Costs Averaged over LOM).

Cost	LOM Total Cost (\$ M)	LOM \$/Tonne Milled	LOM \$/oz Ag Payable
Treatment and Refinement	68.27	36.36	1.37
Transport	63.55	33.85	1.28
Total	131.82	70.22	2.65

19.3.5 TAXATION AND ROYALTIES

- There is an NSR royalty of 1.5% payable to the Government of Canada.
- Approximately CAD 1.2 million of the total CAD 4.0 million has been paid or accrued for as of the date of this Report.
- Taxes include Quartz Mining Tax, federal, and Yukon Taxes. It is assumed that the three operating deposits are treated as 'one mine' for income tax and royalty tax purposes.
- Matthew Blattman, post-tax economic model and analysis QP, has relied upon Hecla and its tax advisors for the calculation of the taxes in the economic model.

19.3.6 CLOSURE COST AND SALVAGE VALUE

For contemporary mining operations, the Government of Yukon requires financial security in an acceptable form (i.e., letter of credit or surety bond) to cover potential liabilities associated with the cost of reclamation and closure.

- As part of QML-0009, Yukon Government currently holds \$9,643,943 in security for the Bellekeno, Lucky Queen, Flame and Moth, Onek, and Bermingham mine operations, the mill area, and the DSTF. This amount was set in 2022, following a third-party review of AKHM's estimate of closure costs.
- As part of Water Licence QZ18-044 YG currently holds an additional \$1,702,490 in security for a total of \$11,346,433 of security held by the Yukon Government as per the AKHM Reclamation and Closure Plan Rev. 6.

There is no salvage value accounted in the cost model.

19.3.7 FINANCING

The economic analysis assumes 100% equity financing and is reported on a 100% ownership basis.

19.3.8 INFLATION

All estimates outlined herein are expressed in 2024 fiscal year prices. All projections are estimated in real terms, and they do not incorporate allocations for inflation.

19.4 ECONOMIC ANALYSIS

19.4.1 PRE-TAX FINANCIAL ANALYSIS AND RESULTS

The pre-tax financial model incorporated the production schedule and smelter term assumptions to produce annual recovered payable metal, or gross revenue, in each concentrate stream by year. Off-site costs, including the applicable refining and treatment costs, penalties, concentrate transportation charges and royalties were then deducted from gross revenue to determine the NSR. Further details of the smelter terms used to calculate the recovered metal value and off-site operating costs and royalties can be found in Section 16.

The operating cash flow was produced by deducting annual mining, processing and G&A from the NSR.

Sustaining and growth capital was deducted from the operating cash flow in the years they occur, to determine the net cash flow before taxes.

The financial analysis was carried out on a 100% Hecla ownership basis.

The LOM material tonnages and produced metal quantities used in the cash flow model are included in Table 19-4.

A summary of the pre-tax financial results is provided in Table 19-6.

Table 19-4 – LOM Production Summary.

Item	Unit	LOM Total	Annual LOM Average
Life of Mine	years	11.0	N/A
Production			
Ore Milled	'000 tonnes	1,877	171
Waste Mined	'000 tonnes	1,275	116
Silver Grade	g/t	912	912
Gold Grade	g/t	0.22	0.22
Lead Grade	%	2.81	2.81
Zinc Grade	%	2.53	2.53
Contained Metal in Mine Production			
Silver	koz	55,068	5,006
Lead	tonnes	52,772	4,797
Zinc	tonnes	47,517	4,320
Process Recoveries (Produced Metals)			
Silver	%	96.0%	96.0%
Lead	%	93.2%	93.2%
Zinc	%	72.0%	72.0%
Produced Metal			

Item	Unit	LOM Total	Annual LOM Average
Silver	koz	52,865	4,806
Lead	tonnes	49,205	4,473
Zinc	tonnes	34,212	3,110

Table 19-5 – Summary of Pre-Tax Financial Results

Description	Units	Total
Produced Metal (Gross Revenue)		
Silver	\$ million	1,092.8
Lead	\$ million	90.8
Zinc	\$ million	68.0
Total Recovered Metal Value	\$ million	1,252
Operating Costs		
Mining	\$/t milled	130.0
Processing	\$/t milled	47.0
G&A	\$/t milled	80.3
Total Operating Cost over LOM	\$ million	483.3
Capital Costs		
Mining	\$ million	158.4
Processing	\$ million	15.9
Infrastructure	\$ million	11.8
Growth Capital	\$ million	79.9
Sustaining Capital	\$ million	106.2
Reclamation and Closure	\$ million	8.7
Total Capital Cost over LOM	\$ million	194.8
Financial Summary		
Pre-Tax Undiscounted Cash Flow	\$ million	439.5
Pre-Tax NPV at 5%	\$ million	318.1

19.4.2 POST-TAX FINANCIAL EVALUATION

Considering the project on a stand-alone basis, the undiscounted after-tax cash flow totals USD 419.8 million over the mine life. For this cash flow analysis, the internal rate of return (IRR) and payback are not applicable since the Keno Hill Mine is producing saleable concentrate and revenue.

Table 19-6 provides a summary of LOM annual cumulative after-tax cash flow.

Table 19-6 Cumulative Cash Flow After-Tax (\$ '000).

Description	Units	Total
Taxes	\$ million	\$19.7
After-Tax Cashflow	\$ million	\$419.8
After-Tax NPV 5%	\$ million	\$304.5

The full annual cash flow model is presented in Table 19-7 in US dollars with no allowance for inflation, showing a pre-tax and after-tax NPV, using a 5% discount rate of USD 318.07 million and USD 304.45 million, respectively.

The QP is of the opinion that that as Keno Hill is an operating mine within a relatively stable tax jurisdiction, the above report section(s) accurately represent the current conditions at the mine. As such, the QP has no additional material recommendations to make.

Table 19-7 – After-Tax Discounted Cash Flow Model

Description	Units	LOM Total	2024	2025	2026	2027	2028	2029	2030	2031	2032	2033	2034	2035
Mining														
Underground														
Production	'000 tonnes	1,877.4	127.3	139.3	146.1	176.9	200.8	200.9	200.9	199.1	200.2	200.4	85.4	
Waste	'000 tonnes	1,274.9	173.4	100.8	47.3	218.2	186.7	138.6	93.0	97.5	93.6	98.7	27.2	
Processing														
Mill Feed	'000 tonnes	1,877.4	127.3	139.3	146.1	176.9	200.8	200.9	200.9	199.1	200.2	200.4	85.4	
Ag Grade	g/t	912.4	943.9	941.4	973.7	855.4	849.1	943.8	990.3	997.8	835.1	808.3	948.2	
Au Grade	g/t	0.22	0.10	0.11	0.13	0.18	0.26	0.30	0.32	0.30	0.28	0.19	0.09	
Pb Grade	%	2.81	2.11	2.05	2.00	2.22	3.47	3.25	3.43	3.63	2.70	2.81	2.03	
Zn Grade	%	2.53	1.34	1.58	1.99	3.23	3.22	3.33	3.30	2.74	2.34	2.08	1.06	
Revenue*														
Silver Concentrate														
Produced Silver	koz	50,663	3,554	3,878	4,209	4,477	5,043	5,608	5,886	5,876	4,946	4,792	2,394	
Produced Lead	tonnes	46,440	2,369	2,514	2,573	3,450	6,127	5,748	6,069	6,357	4,758	4,948	1,527	
Produced Zinc	tonnes	1,901	68	88	116	228	259	268	265	218	187	167	36	
Zinc Concentrate														
Produced Silver	koz	2,203	155	169	183	195	219	244	256	255	215	208	104	
Produced Lead	tonnes	2,765	141	150	153	205	365	342	361	379	283	295	91	
Produced Zinc	tonnes	32,311	1,157	1,493	1,975	3,881	4,397	4,554	4,504	3,714	3,187	2,833	616	
Net Revenue	USD '000	1,117,631	76,334	83,314	91,505	98,994	113,376	124,990	131,043	130,592	109,483	106,203	51,796	
Unit NSR	USD/t milled	595	600	598	626	559	565	622	652	656	547	530	607	
Operating Cost														
Mining (UG)	USD '000	244,147	27,394	21,726	19,409	27,028	21,454	21,910	20,557	20,673	21,476	25,176	17,344	
Processing	USD '000	88,307	7,584	8,050	8,395	8,486	8,651	8,711	8,717	8,636	8,682	8,692	3,702	
G&A	USD '000	150,840	14,481	15,387	15,218	15,137	14,131	14,136	14,139	14,009	14,091	14,105	6,007	
Total Operating Cost	USD '000	483,293	49,458	45,163	43,022	50,651	44,236	44,757	43,412	43,318	44,249	47,974	27,054	

Description	Units	LOM Total	2024	2025	2026	2027	2028	2029	2030	2031	2032	2033	2034	2035
Capital Cost														
Mining	USD '000	158,405	25,562	10,345	7,120	24,772	19,901	14,491	11,544	14,804	12,574	15,365	1,927	0
Processing	USD '000	15,878	1,455	3,923	500	0	0	0	10,000	0	0	0	0	0
Compiled G&A	USD '000	11,825	6,616	2,333	0	385	513	1,133	115	0	730	0	0	0
Closure	USD '000	8,740	0	0	0	0	0	0	0	0	0	0	0	8,740
Total Capital Cost	USD '000	194,848	33,633	16,601	7,620	25,156	20,414	15,625	21,659	14,804	13,304	15,365	1,927	8,740
Cash Flow														
Taxes	USD '000	19,713	0	0	1,337	113	1,830	2,863	2,940	3,438	2,257	1,688	3,247	0
After-Tax Cashflow	USD '000	419,777	-6,756	21,550	39,526	23,074	46,896	61,744	63,032	69,033	49,673	41,176	19,569	-8,740
Project Economics														
After Tax NPV (5%)	USD '000	304,450	-6,435	19,546	34,144	18,983	36,744	46,074	44,796	46,724	32,020	25,279	11,441	-4,867

*Note: gold is a contained metal but is not payable in the current smelter payment terms.

19.5 SENSITIVITY ANALYSIS

Project risks can be identified in both economic and non-economic terms. To assess the robustness of the project's financial results, a sensitivity analysis was conducted in a range of +/- 20% on the key variables that impact the Keno Hill Mine after-tax NPV. Key economic risks were examined by assessing cash flow sensitivities, compared to the base case considering:

- Silver head grade.
- Silver price.
- Exchange rate.
- Operating costs.
- Capital costs (sustaining, growth and closure).

Sensitivities were performed on the key variables for silver because the revenue from silver is approximately 89% of the projects' net revenue stream with lead and zinc providing the remainder. NPV sensitivity over the base case have been calculated for a range of variations. The after-tax sensitivities are shown in Table 19-8.

Table 19-8 – After-Tax NPV Sensitivity Analysis Result Table.

Variance from Base Case	Head Grade (g/t Ag)	5% NPV (\$M)
-20%	729.9	146.38
-10%	821.1	225.59
0%	912.4	304.45
10%	1003.6	362.42
20%	1094.8	420.35
Variance from Base Case	Metal Prices (USD/oz Ag)	5% NPV (\$M)
-20%	17.60	127.79
-10%	19.80	216.38
0%	22.00	304.45
10%	24.20	369.08
20%	26.40	433.68
Variance from Base Case	FX Rate (USD/ CAD)	5% NPV (\$M)
-20%	1.08	307.97
-10%	1.22	306.21
0%	1.35	304.45
10%	1.49	302.00
20%	1.62	299.54
Variance from Base Case	Operating Costs (\$/t)	5% NPV (\$M)
-20%	205.95	356.38
-10%	231.69	330.43
0%	257.43	304.45
10%	283.18	269.75
20%	308.92	234.96
Variance from Base Case	Capital Costs (\$M)	5% NPV (\$M)
-20%	155.88	326.72
-10%	175.36	315.60
0%	194.85	304.45
10%	214.33	289.98
20%	233.82	275.42

The NPV analysis indicates that the project value is most sensitive to the silver metal price, a $\pm 10\%$ variance in silver price resulted in a -29% and +21% variation in NPV.

In addition, the project value is also highly sensitive to silver head grade. For a $\pm 10\%$ variance in Ag head grade, the project resulted in a -26% and +19% variation.

Amongst the selected parameters, project value is least sensitive to the exchange rate and capital cost. The result for capital sensitivity is reflective of the low project capital requirements, leveraging the existing development and infrastructure (sunk cost).

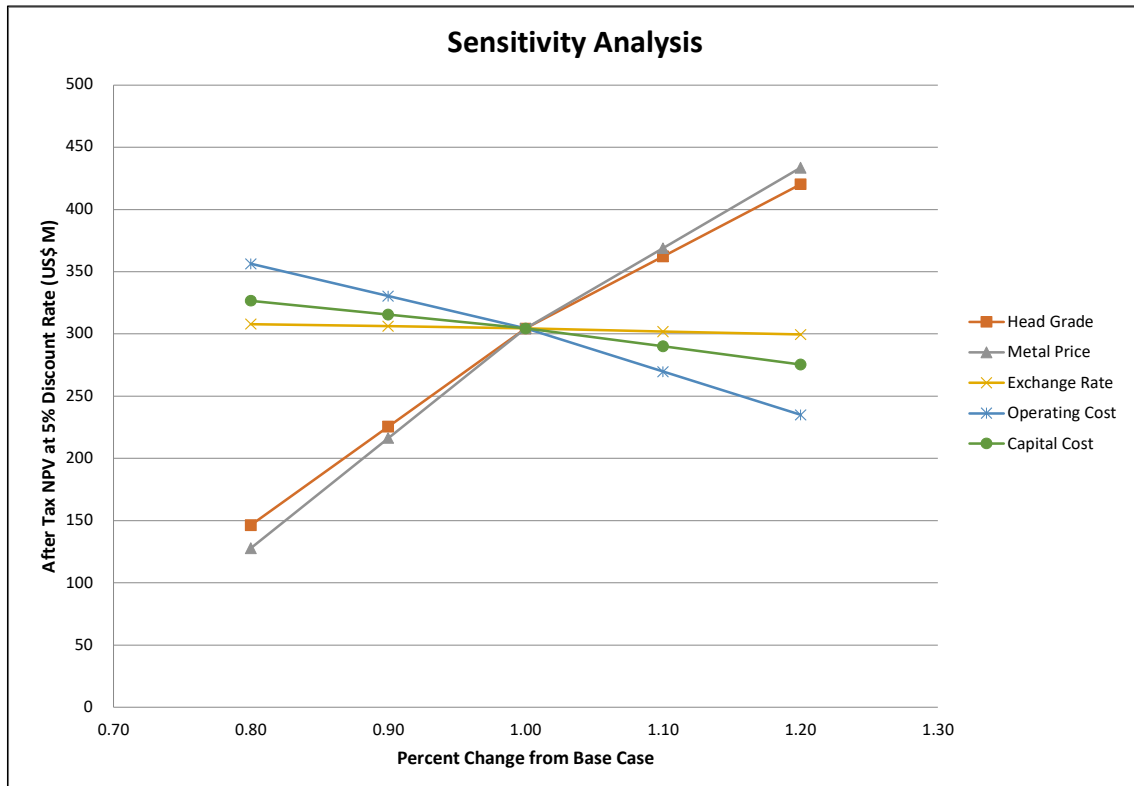

Figure 19-1 – After-Tax 5% NPV Sensitivity (-/+20% Project Variables).

The results of the sensitivity analysis demonstrated that the Keno Hill Mineral Reserve estimate is most sensitive to changes in metal prices, then head grade, followed by operating cost, capital cost, and the exchange rate. It is noted that positive revenue variances to the base case (metal price and head grade) are more impacted from the tax fluctuations which diminishes the gains to the after-tax NPV when compared to the negative variances to the base case. This causes the after-tax NPV to be slightly less sensitive overall to positive cashflow variances than negative.

19.6 COMMENTS ON ECONOMIC ANALYSIS

Hecla’s QP is of the opinion that as Keno Hill is an operating mine within a relatively stable tax jurisdiction, the above report section(s) accurately represent the current conditions at the mine. As such, the QP has no additional material recommendations to make.

20. ADJACENT PROPERTIES

The Property is located within the Keno Hill region which has a long history of mining that has been outlined in other Sections of this report. There are numerous historic and abandoned workings associated with this history.

There are current and historic placer gold mining operations to the east and north of the Property. Victoria Gold Corp.'s Eagle Gold Mine is located 35 km west of the Property along the Silver Trail Highway. Gold mineralization at the Eagle Gold Mine is not considered indicative of the mineralization on the Property and is processed via an open pit and heap leach operation. The Eagle Mine operation may provide both benefits and challenges in terms of available resources for this Property.

Adjoining the Keno Hill tenements to the east and south, Metallic Minerals Corporation (Metallic Minerals) has the Keno Silver project which hosts historic silver mines which may be strike extensions to deposits within the Hecla tenements. Metallic Minerals has been conducting drilling at East Keno testing soil anomalies and geophysical features. Drilling in 2020 intersected high grade Ag-Pb-Zn sulfide vein mineralization which was similar in style to the Keno Hill silver mineralization. Metallic Minerals reports that drilling also intersected a mixed mesothermal and epithermal style of mineralization also noted at the Hecla Silver King deposit. Metallic Minerals is continuing to drill test exploration targets within its tenements and anticipates reporting an inaugural mineral resource estimate in early 2024.

Located to the southwest of the Keno Hill Property, the Banyan Gold Corp (Banyan) AurMac Gold Project is a combination of the Aurex and McQuesten projects optioned from Victoria Gold Corp. and Alexco Resource Corp, respectively, as well as additional claims staked directly by Banyan. On 18th May 2023, Banyan announced an updated Inferred Mineral Resource for the AurMac Property of 6.2 million ounces. The AurMac property is transected by the main Yukon highway and the access road to the Eagle Gold Mine open-pit and heap leach operations.

21. OTHER RELEVANT DATA AND INFORMATION

The QPs are not aware of other data to disclose.

22. INTERPRETATION AND CONCLUSIONS

The responsible QPs make the following interpretations and conclusions within each respective study area based on their review of data available for this TRS.

22.1 PROPERTY DESCRIPTION AND OWNERSHIP

Keno Hill quartz mining claims and quartz mining leases are held by Hecla through its wholly owned subsidiaries ERDC and AKHM. The current property ownership, access and licenses cover the areas included in the geological model, Mineral Resources and Mineral Reserves in this study.

The potential liabilities associated with the historic operations in Keno Hill are indemnified by the Government of Canada under the terms and conditions of the commercial agreement, subject to the requirement for ERDC to develop, permit and implement the site Reclamation Plan for the historic mining activities.

22.2 EXPLORATION AND MINERAL RESOURCES

Mineral Resources for Keno Hill have been prepared to industry best practice and conform to the resource categories defined by the SEC in S-K 1300. Mineral Resources have been stated exclusive of Mineral Reserves.

In the opinion of the QP, the resource evaluations reported herein are a reasonable representation of the global polymetallic Mineral Resources for the Bellekeno, Lucky Queen, Flame and Moth, Onek and Bermingham deposits given the current level of sampling.

Drilling and other source data has supported the update of Mineral Resource estimates with resources issued for the five main deposits at Keno Hill which comprise Bellekeno, Lucky Queen, Flame and Moth, Onek and Bermingham.

In reviewing the Hecla source data, Mining Plus considered and evaluated areas of risk that included exploration drilling, logging and analytical data collection and the associated quality control procedures, survey and location controls, interpretative modeling and the estimation process. Mining Plus considers these are sufficient to support Mineral Resource Estimation and has included the following comments:

- Recent drilling campaigns by Hecla and Alexco have conformed to industry standards; however, drilling preceding Alexco included issues with core or chip quality which limits their utility primarily to exploration purposes.
- Additional resource drilling has been completed on several of the Keno Hill deposits subsequent to the previous technical report completed in 2021 (Alexco, 2021b). Resource and grade control

drilling were completed at the Birmingham deposit and at Flame and Moth. Exploratory drilling investigating extensions to existing resources was completed at Hector-Calumet, Silver King and Coral Wigwam deposits that lie along strike and between the major mineral resource areas.

- The reviewed and validated geological database was considered by the QP to be representative and suitable for constructing interpretative geological models and for the preparation of Mineral Resource estimates. The database was similarly considered suitable for mine design and scheduling and in conjunction with other modifying factors, suitable for Mineral Reserve estimation.
- The most recent drilling campaign (between September 2022 and October 2023) has incorporated drilling procedures used by Alexco and complemented by minor improvements introduced by Hecla. These practices have followed industry standards and are considered suitable for incorporation into the resource estimation. Drilling preceding Alexco typically has included issues with core or chip quality limiting their utility primarily to exploration purposes.
- The data spacing and distribution within the areas of the resource was sufficient to establish the degree of geological and grade continuity appropriate for mineral resource estimation.
- In the drilling database, geology logging prior to 2010 used a different approach for the description of the lithological code with inconsistent logging between both periods. Some records in the database included “NR” (No Recovery) entries in the assay data which were subsequently retained as NULLs in the estimation process. At Flame and Moth, it was noted that the NR intervals constituted around 15% of the total sampled length within some domains.
- Density determination was conducted using combined estimates from a pycnometer method applied to pulp samples and the Archimedes method on segments of drill core.
- Mining Plus considered the assay Quality Control program between 2006 and 2023 was acceptable and no significant contamination was observed with assay samples returning acceptable precision and accuracy without evidence of bias. The following comments on the quality control program were noted:
 - Investigation and documented actions were not at a suitable standard for some assay failures.
 - It was noted that duplication of pulp samples was discontinued as part of the Quality Control program after 2011.
 - Pulverized blank standard controls have not been included as part of the Quality Control program.
- The applied interpretation and modelling criteria appeared to vary from deposit to deposit, including within the same deposit or structure. The interpretations are apparently based on a combination of geology and economic cut-off and a lack of accurate snapping was observed in some deposits. These differences were not considered to have a significant global impact on the mineral resource but could present an impact on a local scale.
- The block model grade interpolation was completed using differing estimation approaches to accommodate local and global biases which remained within the acceptable range. This approach includes estimation with regular parent cells applying proportion of the mineralized zone (Onek, Lucky Queen and Bellekeno) that makes it difficult to optimize underground resources. No

material issue was detected except at the Bellekeno deposit where the resource classification was modified from Indicated to Inferred. Mining Plus noted that different estimation approaches have been applied to each deposit. The Mineral Resource classification has been applied to a reasonable standard where most blocks remain within a distance of 25 m of the source data and included as Indicated resources. It was noted in some cases a distance up to 50 m distance was permitted for the Indicated classification, which is typically wider than what would normally be applied in this style of mineralization.

- The implementation of grade capping was applied on a case-by-case basis. Overall, most of the estimation domains exhibited a low coefficient of variation. For Flame and Moth, a clamp method was employed to limit high-grade values. Whilst this method results in lower than anticipated grades in the high-grade zones, this method shows improved results compared to traditional capping methods. Mining Plus holds the opinion that there are no notable concerns regarding the outcomes of capping. In the case of Birmingham, the capping has been done on the raw data. Mining Plus advises against methods of raw data capping, as this may result in potentially higher loss of metal compared to capping applied to composites. Mining Plus has referred to older mineral resource assessments completed in the period 2010 to 2021 by Dr Gilles Arseneau, Ph.D., P. Geo. from SRK Canada who acted as the QP. Throughout this period Dr. Arseneau conducted diverse reviews of databases and quality control. Further details on these reviews have been included in Section 9 of this Report.
- The implementation of reconciliation in active mining areas is currently ongoing and a comprehensive review is underway. Mining Plus emphasizes that, in accordance with best practices, mining reconciliation remains an important tool in the Mineral Resource value chain. The outcomes from reconciliation studies play a crucial role in enhancing the understanding regarding the veracity of mineral resource estimates and anticipating future improvements.
- Mining Plus observed that the mineralization style and controls are well understood following an extensive period of mining operations and support the continuing release of Mineral Resources.
- Mining Plus considered that Hecla's Keno Hill has excellent potential for further exploration discoveries and for extensions to the current resources that remain on the Property, both along strike and at depth in the immediate resource areas and on other parts of the Property.
- Mining Plus has assumed no risk for the processing and mining costs applied to the NSR economic cut-off for reporting the Mineral Resource estimates. These costs have reportedly been based on previous studies. However, verification with current Hecla costs (mining and processing cost) showed no significant differences in the reported resources.
- Assumptions made for various metal prices were deemed reasonable for reporting Mineral Resources while considering long-term price fluctuations. It remains essential to acknowledge that these parameters could be influenced by significant shifts in the market economy.

It is the opinion of the Mining Plus geology QP that the Mineral Resource models presented in this report are representative of the informing data and that the data is of sufficient quality and quantity to support the Mineral Resource estimate to the classifications applied.

22.3 MINING AND MINERAL RESERVES

- Mineral Reserves have been classified in accordance with the definitions for Mineral Reserves in S-K 1300.
- Mineral Reserves as of December 31, 2023 total 1.88 Mt grading 912 g/t Ag, 0.22 g/t Au, 2.81% Pb, and 2.53% Zn.
- Indicated Mineral Resources were converted to Probable Mineral Reserves. Inferred Mineral Resources were not converted to Mineral Reserves, however, are typically included in the Keno Hill long-range plan and therefore are removed from the life of mine cash flows to ensure economic confirmation of the Mineral Reserves.
- Mineral Reserves are estimated by qualified professionals using modern mine planning software in a manner consistent with industry practice.
- The mining method at KHM is overhand mechanized cut and fill (MCF) using cemented and uncemented rockfill as backfill. MCF is a highly selective method that enables the Mineral Reserves to be extracted safely and economically while adapting to the variable nature of the narrow vein geometry.
- Mill feed will come predominantly from the Birmingham deposit (70%), followed by the production from Flame and Moth (24%), and supplemented by Lucky Queen ore (6%).
- The current LOM period is estimated to be eleven years ending in 2034.
- The key risks to achieving the design basis include:
 - Slower excavation rates, increased dilution, and increased ground support costs due to the relatively poor nature of the rock mass.
 - Localized conditions of higher water flow around water bearing structures.
 - Due to the relatively small nature of the operation, any unplanned breakdowns may have a potentially large effect.

The QP considers that the mine plan is sound, as it is based on conventional mining techniques, reasonable production assumptions, and due consideration of potential risks to achieving the mine plan. As the mine matures, the overall mine plan benefits from the flexibility of having multiple working fronts to achieve the desired production rate. The Mineral Reserves are subject to the type of risks that are common to underground polymetallic narrow vein mining operations and may be materially affect by the following risk factors:

- Changes in realized metal prices from what was assumed.
- Changes to the mining costs, processing and G&A costs used to calculate the cut-off grade.
- Changes in local interpretation of mineralization geometry or modelled continuity of mineralized zones.
- Changes to geotechnical or hydrogeological design assumptions resulting in schedule delays, increased dilution or reduced recoveries.
- Changes to mining and metallurgical recoveries.
- Changes in the long-term assumptions relating to concentrate payability, marketability and penalty terms.

- Changes in the mining development or geotechnical conditions resulting in additional unplanned dilution.
- Changes to the current mining method where certain zones or lenses permit.
- Assumptions as to the continued ability to access site, retain mineral tenure, obtain required environmental, mining, and other regulatory permits, and maintain a social license to operate with relevant stakeholders.

22.4 METALLURGICAL TESTING AND MINERAL PROCESSING

The Keno Hill Mine is currently engaged in mining and milling operations with an on-site mill producing silver-lead and zinc concentrates. Hecla has completed all mill upgrades planned by the former site operator, Alexco to support the future increase from 400 tpd to 550 tpd throughput.

22.5 INFRASTRUCTURE

The current infrastructure servicing the Keno Hill Mine is expected to be sufficient to sustain operations and Hecla has plans for refurbishment or repair as necessary within the mine plan. The following projects are some planned sustaining capital projects that should add capacity to the current DSTF and allow for the mine plan to utilize tailings in the underground cemented backfill.

- Hecla plans to build a CRF/tailings plant near Bermingham portal to support ongoing backfill activities at the Keno Hill Mine.
- Hecla plans to increase the capacity of the DSTF with a Phase 2 and Phase 3 extension.

DSTF Phase 2 construction is scheduled to start in summer 2024. The design is currently being revised to incorporate comments received from the Yukon Government. Design revisions include revisions to the seismic criteria and re-evaluation of geotechnical design under updated criteria.

The current permit limits for the Dry Stack Tailings Facility and the Waste Rock Dump Facility are insufficient to cover the planned waste rock and tailings produced over the LOM. Permitting studies are underway, and a reasonable timeframe has been identified in the LOM to obtain appropriate permits to establish additional facilities for tailings and waste rock dumps.

22.6 ENVIRONMENTAL STUDIES, PERMITTING, SOCIAL OR COMMUNITY IMPACTS

Hecla is committed to operating in compliance with all regulations and standards of good practice for environmental, health, and safety. To uphold this commitment Hecla has developed and approved corporate policies for environmental, health and safety practices and has prepared a detailed

management plan to facilitate the continuous improvement of its environment and health and safety performance. An Environmental Management System is currently in the process of being implemented, completion is expected by the end of 2024.

Permits held by Hecla for the KHM are sufficient to ensure that mining activities are conducted within the regulatory framework required by regulations. The QP notes that the Bellekeno, Bermingham, and Flame and Moth mines have all permits and authorizations in place to commence or continue with full-scale mine production. The Bermingham deposit has the required permits to sustain mine production for a number of years, however, it will require an amendment to include recent additions to the Mineral Reserve in Bermingham Deep Northeast Zone. The Lucky Queen deposit has in place a Quartz Mining Licence (QML-0009) which authorizes mining operations, but Water Licence QZ18-044 would require an amendment before water-based activities for Lucky Queen can proceed.

To maintain full-scale production for an extended period of time, or to increase production at those deposits, it is likely that modifications to certain permits will be required, including the Quartz Mining Licence (QML-0009), and the Water Licence QZ18-044, in order to increase water discharge amounts/rates, increase the volume or change location of waste rock and tailings storage, or other changes.

In addition, Hecla is progressing work to increase the current permit limits for the Dry Stack Tailings Facility and the Waste Rock Dump Facility as they are insufficient to cover the planned waste rock and tailings produced over the LOM. There is a reasonable expectation that Hecla will receive the required permits to proceed with the proposed LOM plan.

The mine design meets current standards and the implementation of the proposed environmental and health and safety practices ensures that the Keno Hill Mine is prepared to meet future challenges.

22.7 CAPITAL AND OPERATING COSTS AND ECONOMIC EVALUATION

The capital cost and operating estimates were generated by Hecla and reviewed in detail and modified where necessary by the Mining Plus mining QP. The QP considers the accuracy of the components of the capital cost estimate to be appropriate for an operating mine supported by historical costs and recent estimates.

The risks to both sustaining capital and operating costs are mitigated by several factors: the established site infrastructure including an operating mill, existing access to all three mines including advanced development in Flame and Moth and Lucky Queen mines. The majority of the operating costs are based on current estimates and performance with reasonable allowances for improvement through operational efficiencies and application of best practices in MCF development.

The sustaining capital cost for the project is USD 106.2 M with growth capital of USD 79.9 M and the reclamation and closure cost is USD 8.7 M for a total of USD 194.8 M. Operating costs average USD \$257.43/t of ore over the life of mine.

22.8 ECONOMIC ANALYSIS

The economic model for the project was developed by Hecla and reviewed in detail by the Mining Plus mining QP and the post-tax economic analysis QP, Mr. Matthew Blattman. KHM benefits from the operational history, safe jurisdiction and existing permits, as well as the existing infrastructure. Although a brownfields operation, the limitation of liabilities for the historic impacts of mining provides mitigation to that risk of liability and higher than expected closure costs.

Total cumulative after-tax cash flow to the project is USD 419.8 M. The before and after-tax Net Present Value of the project are USD 318.1 M and USD 304.5 M respectively at a 5% annual discount rate. The before and after-tax Internal

Based on the assumptions in the model, the conclusions are that this Project provides a robust cashflow over the eleven-year mine life, producing high value lead-silver and zinc concentrates. The NPV analysis indicates that the project value is most sensitive to the silver metal price, a $\pm 10\%$ variance in silver price resulted in a -29% and +21% variation in NPV.

In addition, the project value is also highly sensitive to silver head grade. For a $\pm 10\%$ variance in Ag head grade, the project NPV can vary by -26% and +19%.

Amongst the selected parameters, project value is least sensitive to the exchange rate and capital cost. The result for capital sensitivity is reflective of the low project capital requirements, leveraging the existing development and infrastructure (sunk cost).

The results of the sensitivity analysis demonstrated that the Keno Hill Mineral Reserve estimates are most sensitive to changes in metal prices, then head grade, followed by operating cost, capital cost, and the exchange rate. It is noted that positive revenue variances to the base case (metal price and head grade) are more impacted from the tax fluctuations which diminishes the gains to the after-tax NPV when compared to the negative variances to the base case. This causes the after-tax NPV to be slightly less sensitive overall to positive cashflow variances than negative.

23. RECOMMENDATIONS

23.1 INTRODUCTION

This section contains a summary of recommendations and opportunities that could be considered for implementation in the future to de-risk, optimize and potentially extend the life of the Keno Hill Mine. The QPs provide the following recommendations.

23.2 GEOLOGY AND MINERAL RESOURCES

Hecla has maintained an active exploration program that seeks to identify mineralization extensions and to support the evaluation of mineral resources and provide grade control definition ahead of mining operations. Mining Plus considers the drilling, logging and drill core meet existing industry standards and are sufficient to support Mineral Resource Estimation and includes the following comments and recommendations:

- Mining Plus has recommended that the current data spacing, and distribution is maintained at all deposits and suggested monitoring the subsequent geological and grade continuity to ensure it continues to be appropriate for Mineral Resource Estimation.
- Review the logging disparities identified in drillings conducted before 2010 and conduct a comprehensive assessment of logging consistency across various drilling campaigns. This review aims to enhance the interpretation and modeling criteria for mineralized structures.
- Discrepancies observed between the entered assay data and the laboratory certificates were noted in the Onek database, and to a lesser extent at Bellekeno and Lucky Queen. Mining Plus considers that a more comprehensive audit be conducted to address these inconsistencies and verify if any other issues exist.
- Constant monitoring of the pulp bulk density is recommended by conducting checks using the paraffin wax method on samples estimated using the Archimedes density method. The checks will provide information on any relevant biases and must be included in the company's procedures.
- Mining Plus considers that adjustments to the procedures for underground face sampling and an improvement in onsite assaying may be sufficient to support the incorporation of face samples within future grade estimation processes. Face samples are normally reliable source data for estimations as they can be controlled at uniform boundaries and set locations within the mining development. Face sample data represents the closest spaced samples that can be used to determine local grade variability or continuity.
- Mining Plus recommends the following improvements to the Quality Control program:
 - Hecla should include an investigation of the origin of any quality control failures and to implement timely corrective measures.

- Hecla should continue to incorporate field duplicates, pulp duplicates and umpire check samples as essential parts of the Quality Control procedure to assess the precision of samples at various stages of sampling and comminution.
- The incorporation of pulverized blank standard samples is recommended to evaluate contamination during the analysis stage.
- The applied geological interpretation and modelling criteria should be clearly defined and consistent during the interpretation of each structure and deposit, which will help improve precision in locally estimated resources.
- It is recommended that future resource estimates should establish clear and consistent estimation criteria as far as practicable, including:
 - An update of the estimated resources at Onek, Lucky Queen and Bellekeno, with appropriate documentation and traceability of the data and information used is strongly recommended.
 - The block model should use parent cells and sub cells to facilitate underground optimizations.
 - A consistent capping method be applied uniformly across all deposits. The recommended approach is to consider capping after the compositing process, where the influence of high grades is mitigated.
 - The NSR economic cut-off should be based on Hecla's current costs, which should include at a minimum the cost of mine and mineral processes, which can be tangible and realistic depending on the level of knowledge of mining development in the area.
- Monitor the estimation results of those domains with no record (NR or NULL) intervals mainly in Flame and Moth, to see potential risks in this area resulting from these samples.
- Continue with the Resource classification criteria for Indicated Resources using a distance of 25 m, which should be consistent wherever possible for all deposits.
- Implement mining reconciliation practices that help to better understand the veracity of mineral resource estimates and anticipate future improvements.

23.3 MINING AND MINERAL RESERVES

The QP notes that the overall mine plan benefits from increased flexibility and working fronts as the mine matures and the capital development advances. In the initial years, there is an opportunity to further de-risk the overall LOM plan and better predict the operational performance of future mining zones by addressing the following items:

- Undertake a more detailed dilution and extraction study, including consideration of any existing reconciliation studies, to better quantify the extraction recovery, dilution, and other modifying factors that Hecla is currently applying to all production designs. Specifically, the final cut underneath a planned sill can be expected to have a higher dilution from CRF failure due to blasting cycles of the final lift and previous lift. Use the results of the above noted studies to

determine the actions necessary to align mine production grades with the Mineral Reserve Estimates.

- Complete additional geotechnical assessments to determine the amenability of the orebody to more productive and less costly mining methods. There is an opportunity to trial stope mining methods in the Flame and Moth between 2024 and 2026 to refine the method and application without affecting the overall LOM plan.
- Complete additional optimization on the Mineral Reserve mine plan and de-risk the mine plan on a development basis by assessing the potential for slower than planned increases to efficiency and underground unit development operations. Complete additional scenario scheduling to better understand the risk and plan appropriately to meet the schedule.
- Continue evaluating the option of mining at Flame and Moth earlier than planned as a large portion of the underground access has been completed and the mine is ready to produce ore with minimal development. This will assist with reducing the LOM plan risk by creating additional mining fronts with minimal upfront capital.
- Continue conducting definition diamond drilling throughout the remainder of the underground mining operation to convert Inferred to Indicated Mineral Resources and increase the understanding of the mineralization. Doing so may result in increased Mineral Reserves near planned capital and operational development and reduce the overall capital development intensity of the schedule.
- Investigate adding marginal underground Indicated Mineral Resources to the Mineral Reserves where appropriate.
- Complete hydrogeological studies to better understand the sources of water at Flame and Bermingham
- Review mining plans and benchmark other relevant Hecla operations to define definitive actions to attain the planned improvements in mining productivity, daily development advance and associated costs over the first four years.

23.4 MINERAL PROCESSING

The QP considers that there is an opportunity to improve the level of detail of the metallurgical predictions and particularly the concentrate production at a month-to-month operational level. Further locked cycle tests at the next stage of study are recommended for samples representing the Flame and Moth deposit and different blends according to the LOM production plan. There may be an opportunity to improve the concentrates grades with further testing, particularly of the zinc concentrate. Additional metallurgical testing at different head grades would also support the approach to capping recoveries, particularly for the compartment of lead to concentrates at lower head grade mill feed. In addition, further hardness tests are recommended on these samples to verify potential grindability variations for future mill feeds. It is also recommended that testing of the increased plant throughout above the 400 tpd be done in the first year of operation to identify potential bottlenecks and confirm requirements for mill modifications to achieve the 550 tpd throughput. Sedgman recommends that Hecla perform a series of debottlenecking

exercises and productivity tests on the mill prior to and well in advance of the expected throughput increases. This will help to derisk the production profile and ensure a smooth ramp up.

23.5 ENVIRONMENTAL STUDIES, PERMITTING, SOCIAL OR COMMUNITY IMPACTS

The QP notes that that the Mineral Reserves contain material that is not fully permitted for extraction at both Bermingham (Bermingham Northeast Deep Zone) and Lucky Queen.

The QP recommends that Hecla continue with its planned permit approvals and amendment process to reduce the risk to the overall mine plan and investigate alternatives if required.

23.6 ECONOMICS ANALYSIS

The QP is of the opinion that as Keno Hill is an operating mine within a relatively stable tax jurisdiction, and the information contained in Section 19.4-Economic Analysis accurately represent the current conditions at the mine. As such, the QP has no additional material recommendations to make.

24. REFERENCES

- Alexco, 2019a. Alexco Keno Hill Mining Corp. Type A Water Licence QZ09 -092 Renewal Application QZ18-044, Keno Hill Silver District Mining Operations. April 2019.
- Alexco, 2019b. Alexco Resource Corp. NI-43101 Pre-feasibility Study the Keno Hill Silver District Project, Yukon Territory, Canada, May 8, 2019.
- Alexco, 2020. Alexco Resource Corp. NI 43-101 Technical Report Prefeasibility Study of the Keno Hill Silver District Project, Yukon Territory, Canada. Amended February 13, 2020.
- Alexco, 2021a. Alexco Resource Corp. Press Release. Alexco Extends Bermingham High-Grade Mineralization at Depth, Intersects 3,583 g/t Silver over 8.76 meters True Width and Other Significant Results. January 19, 2021.
- Alexco, 2021b. Alexco Resource Corp. NI 43-101 Technical Report on Updated Mineral Resource and Reserve Estimate of the Keno Hill Silver District. May 26, 2021.
- Alexco, 2021c. Alexco Resource Corp. Press Release. Alexco Reports Interim Results from Bermingham Drilling, Composite Assays to 1,681 g/t Ag over 20.37 meters True Width. September 7, 2021.
- Alexco, 2021d. Alexco Resource Corp. Press Release. Alexco Reports Final Results from 2021 Bermingham Drilling Program, Composite Assays to 1,383 g/t Ag over 11.09 Meters True Width. December 16, 2021.
- Alexco, 2022a. Alexco Keno Hill Mining Corp. 2021 Annual Report Quartz Mining Licence QML-0009. Report prepared for Yukon Government - Energy, Mines and Resources. March, 2022.
- Alexco, 2022b. Alexco Resource Corp. Management's Discussion and Analysis for the Three and Six Month periods Ended June 30, 2022.
- Barton et al., 1974. Barton, N., Lien, R., Lunde, J., 1974. Engineering Design of Tunnel Support. Rock Mechanics Vol. 6 No. 4. (Chapter 13).
- Beaudoin and Sangster, 1992. Beaudoin G. and D. F. Sangster. 1992. A Descriptive Model for Silver-lead-zinc Veins in Clastic Metasedimentary Terranes. Economic Geology V.87 July 1, 1992.
- Boyle, 1965. Boyle, R.W. 1965. Geology, Geochemistry, and Origin of the Lead-zinc-silver Deposits of the Keno Hill-Galena Hill Area, Yukon Territory, Geol. Surv. Canada, (Bull. 111, p. 302).
- Cathro, 2006. Cathro, R. J., 2006. The History and Geology of the Keno Hill Silver Camp, Yukon Territory, Geoscience Canada, v 33, No. 3, P. 103-134 (2006).
- Deere, 1964. Deere, D. U., 1964. Technical Description of Rock Cores for Engineering Purposes. Rock Mechanics and Engineering Geology, 1 (16-22). (Chapter 16).

EBA, 2008. EBA Engineering Consultants Ltd. Typical Waste Containment Facility Design – Keno Hill Silver District, YT – Construction Specifications. Report prepared for Alexco Resource Corporation, issued July 2008.

EBA, 2010a. EBA Engineering Consultants Ltd. Preliminary Engineering Design and Management Plan – Dry-Stacked Tailings Facility – Bellekeno Mine Mill Site, Yukon. Report prepared for Alexco Resource Corporation, issued January 2010.

EBA, 2010b. EBA Engineering Consultants Ltd. Runoff Diversion Structure Specs – Dry Stack Tailings Facility – Keno Hill District Mill, YT. Specifications prepared for Alexco Keno Hill Mining Corporation, issued September 27, 2010.

EBA, 2011. EBA Engineering Consultants Ltd. Detailed Design - Dry Stacked Tailings Facility - Keno Hill District Mill Site, Yukon. Report prepared for Alexco Resource Corp., May 11, 2011.

EBA, 2013. EBA Engineering Consultants Ltd. Dry Stacked Tailings Facility – Expansion Design Report Keno Hill District Mill Site, Yukon. Report prepared for Alexco Resource Corporation, issued February 27, 2013.

Ecofor, 2018. Ecofor, 2018. Heritage Resource Overview Assessment: Alexco-Banyan Keno Hill Silver District. May 2018.

Ensero, 2020. Ensero Solutions Ltd. Geochemical Characterization of Bermingham Locked Cycle Tailings. Report prepared for Alexco Keno Hill Mining Corporation, issued September 9, 2020.

Farrow and McOnie, 2013. Farrow and McOnie, 2013. Updated Technical Report on the Flame & Moth Property, Keno Hill District, Yukon. 15th March 2013. Prepared for Alexco Resource Corp. SRK Consulting (Canada) Inc.

Greybeal and Vikre, 2010. Greybeal, F.T. and Vikre, P.G. (2010). A Review of Silver Rich Mineral Deposits and Their Metallogeny. Society of Economic Geology, Special Publication 15. January 1, 2010.

Hecla, 2022a. Hecla Mining Company. Hecla Acquires Alexco Resource. Press Release 5th July 2022.

Hecla, 2022b. Hecla Mining Company. Hecla Reports Third Quarter 2022 Results. Press Release 9th November 2022.

Hecla, 2022c. Hecla Mining Company. Hecla Yukon Keno Hill Silver District Bermingham Mine Ground Control Management Plan (GCMP) October 2022.

Hecla, 2023a. Hecla Mining Company. Hecla Reports Highest Silver Reserves in Company History. Press Release, 14th February 2023.

Hecla, 2023b. Hecla Mining Company. Quarterly Report Keno Hill Surface Exploration. Internal Report, 7th July 2023.

Hecla, 2023c. Hecla Mining Company. Hecla Reports Second Quarter 2023 Results. Press Release 8th August 2023.

Hecla, 2023d. Hecla Mining Company. GCMP Update September 2023. Internal Document.

Hecla, 2023e. Hecla Mining Company. Mineral Resource Estimate for Flame and Moth. Internal Report, 21st November 2023.

Hecla, 2023g. Hecla Mining Company. Mineral Resource Estimate for Bermingham. Internal Report, 17th December 2023.

Hecla, 2024. Hecla Mining Company. KH SK1300 cost model -r5. Internal Document. February 2, 2024.

Jacobs, 2019. Jacobs Engineering (Jacobs). Pre-feasibility Study Geotechnical Engineering. Report prepared Alexco Resource Corp. March 21, 2019.

Mair et al., 2006. Mair, Hart, J.L., C.J.R. and Stephen, J.R. (2006). Deformation History of the Northwestern Selwyn Basin, Yukon, Canada: Implication for Orogen Evolution and Mid-Cretaceous Magmatism; Bulletin of the Geological Society of America, vol. 118, p. 304-323.

McOnie and Read, 2009. McOnie, A. and Read, P.B., 2009. Stratigraphy, Structure and Exploration Opportunities Sourdough, Galena and part of Keno Hills, Keno Hill Mining Camp, Central Yukon. Internal Report Alexco Resource Corp.

Murphy, 1997. Murphy, D. C., 1997. Geology of the McQuesten River Region, Northern McQuesten and Mayo Map Areas, Yukon Territory (115P/14, 15, 16I 105M/13, 14), Exploration and Geological Services Division, Yukon, Indian and Northern Affairs Canada, Bulletin 6, p.122.

Rescan, 1996. Rescan, 1996. FS. Mine Reopening – Operating Plan Report No. UKH/96/03. Report prepared for United Keno Hill Mines Ltd., August 1996.

Roots, 1997. Roots, C.F., 1997 – Geology of the Mayo Map Area, Yukon Territory (105M), Geological Survey of Canada Bulletin 7, p. 82.

RPA, 2017. RPA. Technical Report Preliminary Economic Assessment of the Keno Hill Silver District Project. Report prepared for Alexco Resource Corp. and filed on SEDAR March 29, 2017.

SGS, 2018a. SGS. An Investigation into The Flotation of Samples from the Bermingham Deposit prepared for Alexco Resource Corp. Project 15774-001 – SGS Final Report, October 25, 2018.

SGS, 2018b. SGS. An Investigation into The Comminution and Flotation of Samples from the Lucky Queen and Flame & Moth Deposits prepared for Alexco Resource Corp. Project 15774-002 – SGS Final Report, November 29, 2018.

SGS, 2019. SGS. An Investigation into The Flotation of Samples from The Bermingham and Christal Zone Deposits, prepared for Alexco Resource Corp. Project 15774-002 – SGS Final Report #2 March 15, 2019 prepared by SGS Canada Inc.;

SRK, 2011a. SRK Consulting. Technical Report on the Lucky Queen Deposit, Lucky Queen Property, Keno Hill District, Yukon. SRK Project 2CA017.001. Prepared for Alexco Resource Corp. September 8, 2011.

SRK, 2011b. SRK Consulting. Technical Report on the Onek Deposit, Keno Hill District, Yukon, Onek Property, Keno Hill District, Yukon. SRK Project 2CA017.001. Prepared for Alexco Resource Corp. September 8, 2011.

SRK, 2012a. SRK Consulting. Technical Report on the Flame & Moth Deposit, Flame & Moth Property, Keno Hill District, Yukon. SRK Project 2CA017.004. Prepared for Alexco Resource Corp, August 8, 2012.

SRK, 2012b. SRK Consulting. Bermingham NI 43-101 Technical Report. SRK project 2CA017.004. Report prepared for Alexco Resource Corp. August 8, 2012, effective date of June 15, 2012.

SRK, 2013. SRK Consulting. Updated Preliminary Economic Assessment for the Eastern Keno Hill Silver District Project – Phase 2, Yukon, Canada, November 2013

SRK, 2014. SRK Consulting. Updated Preliminary Economic Assessment for the Keno Hill Silver District Project – Phase 2, Yukon, Canada, Report prepared for Alexco Resource Corp, December 2014.

S&A, 2013. Starkey & Associates. Bellekeno Grinding Circuit Comminution Throughput Analysis Report. Report prepared for Alexco Resource Corp. March 15, 2013. (Chapter 17)

Tetra Tech, 2015. Tetra Tech EBA Inc. Dry Stacked Tailings Facility Phase II Expansion Preliminary Design – Revision I – Keno Hill District Mill Site, YT. Report prepared for Alexco Resource Corporation, issued June 2, 2015.

Tetra Tech, 2023. Tetra Tech, 2023. Tailings Management Plan for Dry Stack Tailings Facility, Keno Mine, Yukon. June 16, 2023.

UKHM, 1997. UKHM, 1997. Unpublished report on “Mineral Resources and Mineable Ore Reserves” dated March 9, 1997.

Wardrop, 2009. Wardrop, 2009. Bellekeno Project Updated Preliminary Economic Assessment Technical Report. Independent technical report prepared for Alexco Resource Corp. and filed on SEDAR (www.sedar.com).

25. RELIANCE ON INFORMATION PROVIDED BY REGISTRANT

This TRS has been prepared by the Qualified Persons (QPs) for Hecla Mining Company (the Registrant). The QPs have relied on information provided by the Registrant to inform this TRS. The findings, conclusions, opinions, and estimates contained herein are based on the following:

The Mining Plus QP has relied on Hecla for guidance on royalties, and other government levies or interests, applicable to revenue or income from the Property in the Executive Summary and Section 19.

The QPs have not independently verified the market studies and pricing basis for Mineral Resources, Mineral Reserves, and economics. The QPs have fully relied upon the information derived from Hecla and expert reports retained by Hecla for this information through the following documents:

- Consensus Economics Inc, Energy and Metals Consensus Forecasts, December 11, 2023.
- Hecla Mining Company, Proposed2023YearEndMetalPrices, dated August 18, 2023.

Metals price forecasting is a specialized business requiring knowledge of supply and demand, economic activity and other factors that are highly specialized and requires an extensive global database that is outside of the purview of a QP. The QPs consider it reasonable to rely upon Hecla to provide metal price forecasts and marketing information on the silver and zinc concentrates as they sought expert input for this information. This information is used in Section 16 of the Report. The information is also used in support of the Mineral Resource Estimate in Section 11, the Mineral Reserve Estimate in Section 12, and economic analysis in Section 19.

Mining Plus's QP has not researched property title or mineral rights for KHM and consider it reasonable to rely on Hecla's Land Administration personnel who are responsible for maintaining this information.

This information is used in Appendix A, Section 3 Property Description, and the Executive Summary.

The QPs have fully relied upon the information supplied by Hecla Mining Company and experts retained by Hecla Mining Company, for information related to environmental permitting, permitting, closure planning and related cost estimation, and social and community impacts. This information is publicly available via the Government of Yukon, Yukon Water Board and Yukon Environmental and Socio-Economic Assessment Board websites.

This information is used in Section 17 of the Report. The information is also used in support of the Mineral Resource Estimate in Section 11, the Mineral Reserve Estimate in Section 12, capital and operating costs in Section 18 and the economic analysis in Section 19.

The QPs have taken all appropriate steps, in their professional opinion, to ensure that the above information from Hecla is sound.

Except for the purposes legislated under US securities laws, any use of this TRS by any third party is at that party's sole risk.

26. DATE AND SIGNATURE PAGE

This report titled “S-K 1300 Technical Report Summary on the Keno Hill Mine, Yukon, Canada” with an effective date of December 31, 2023, was prepared and signed by:

Qualified Person or Consulting Firm	Responsible Sections	Signature	Date
Mining Plus Canada Ltd.	1.1, 1.2, 1.3, 1.4, 1.5, 1.6, 1.7, 1.10, 1.11, 1.12.1, 1.13, 1.14.1, 1.14.2, 1.14.4, 2, 3, 4, 5, 6, 7, 8, 9, 11, 12, 13, 16, 17, 18, 19.1, 19.2, 19.3, 20, 21, 22.1, 22.2, 22.3, 22.6, 22.7, 23.1, 23.2, 23.3, 23.5, 24, 25	“signed”	February 15, 2024
Ms. Christina Vink, P.Eng.	1.8, 1.9 (excludes waste rock management and DSTF), 1.14.3, 10, 14, 15.1, 15.2, 15.3, 15.4, 15.5, 22.4, 22.5, 23.4	“signed”	February 15, 2024
Mr. Baoyao Tang, P.Eng.	1.9 (waste rock management and DSTF only), 15.6, 15.7	“signed”	February 15, 2024
Mr. Matthew Blattman, PE	1.12.2, 1.12.3, 19.4, 19.5, 19.6, 22.8, 23.6	“signed”	February 15, 2024

APPENDIX A

Appendix A

Hecla Quartz Mining Claim and Lease Holdings in the Keno Hill

Excluding the Tailings Property

Grant	Lease	Status	Claim Name	Owner	Staked	Recorded	Expiry	Renewal Cost per Term (CAD)	Term (Years)
2		Active	43	Alexco Keno Hill Mining Corp. - 100%	2004/08/21	2004/08/23	2028/12/31	\$525	5
55590	NM00297	Active	ABEL	Alexco Keno Hill Mining Corp. - 100%	1946/10/08	1947/03/28	2025/02/23	\$210	21
YC02775		Active	Ag	Alexco Keno Hill Mining Corp. - 100%	2001/07/09	2001/07/10	2030/12/31	\$525	5
62132	NM00555	Active	AGRAM	Alexco Keno Hill Mining Corp. - 100%	1952/06/03	1952/06/17	2027/11/02	\$210	21
YC48132		Active	Alex 1	Alexco Keno Hill Mining Corp. - 100%	2006/05/26	2006/06/02	2043/12/31	\$525	5
YC48141		Active	Alex 10	Alexco Keno Hill Mining Corp. - 100%	2006/05/20	2006/06/02	2043/12/31	\$525	5
YC48231		Active	Alex 100	Alexco Keno Hill Mining Corp. - 100%	2006/05/22	2006/05/22	2043/12/31	\$525	5
YC48232		Active	Alex 101	Alexco Keno Hill Mining Corp. - 100%	2006/05/22	2006/05/22	2043/12/31	\$525	5
YC48233		Active	Alex 102	Alexco Keno Hill Mining Corp. - 100%	2006/05/22	2006/05/22	2043/12/31	\$525	5
YC48234		Active	Alex 103	Alexco Keno Hill Mining Corp. - 100%	2006/05/22	2006/05/22	2043/12/31	\$525	5
YC48235		Active	Alex 104	Alexco Keno Hill Mining Corp. - 100%	2006/05/22	2006/05/22	2043/12/31	\$525	5
YC48236		Active	Alex 105	Alexco Keno Hill Mining Corp. - 100%	2006/05/22	2006/05/22	2039/12/31	\$525	5
YC48237		Active	Alex 106	Alexco Keno Hill Mining Corp. - 100%	2006/05/22	2006/05/22	2043/12/31	\$525	5
YC48238		Active	Alex 107	Alexco Keno Hill Mining Corp. - 100%	2006/05/22	2006/05/22	2043/12/31	\$525	5
YC48239		Active	Alex 108	Alexco Keno Hill Mining Corp. - 100%	2006/05/22	2006/05/22	2043/12/31	\$525	5
YC48240		Active	Alex 109	Alexco Keno Hill Mining Corp. - 100%	2006/05/22	2006/05/22	2043/12/31	\$525	5
YC48142		Active	Alex 11	Alexco Keno Hill Mining Corp. - 100%	2006/05/20	2006/06/02	2043/12/31	\$525	5
YC48241		Active	Alex 110	Alexco Keno Hill Mining Corp. - 100%	2006/05/22	2006/05/22	2043/12/31	\$525	5
YC48242		Active	Alex 111	Alexco Keno Hill Mining Corp. - 100%	2006/05/22	2006/05/22	2043/12/31	\$525	5
YC48243		Active	Alex 112	Alexco Keno Hill Mining Corp. - 100%	2006/05/22	2006/05/22	2043/12/31	\$525	5
YC48244		Active	Alex 113	Alexco Keno Hill Mining Corp. - 100%	2006/05/22	2006/05/22	2043/12/31	\$525	5
YC48245		Active	Alex 114	Alexco Keno Hill Mining Corp. - 100%	2006/05/22	2006/05/22	2043/12/31	\$525	5
YC48246		Active	Alex 115	Alexco Keno Hill Mining Corp. - 100%	2006/05/22	2006/05/22	2043/12/31	\$525	5
YC48247		Active	Alex 116	Alexco Keno Hill Mining Corp. - 100%	2006/05/22	2006/05/22	2043/12/31	\$525	5
YC48248		Active	Alex 117	Alexco Keno Hill Mining Corp. - 100%	2006/05/22	2006/05/22	2043/12/31	\$525	5
YC48249		Active	Alex 118	Alexco Keno Hill Mining Corp. - 100%	2006/05/22	2006/05/22	2043/12/31	\$525	5
YC48250		Active	Alex 119	Alexco Keno Hill Mining Corp. - 100%	2006/05/22	2006/05/22	2043/12/31	\$525	5
YC48143		Active	Alex 12	Alexco Keno Hill Mining Corp. - 100%	2006/05/20	2006/06/02	2043/12/31	\$525	5
YC48251		Active	Alex 120	Alexco Keno Hill Mining Corp. - 100%	2006/05/22	2006/05/22	2043/12/31	\$525	5

Grant	Lease	Status	Claim Name	Owner	Staked	Recorded	Expiry	Renewal Cost per Term (CAD)	Term (Years)
YC48252		Active	Alex 121	Alexco Keno Hill Mining Corp. - 100%	2006/05/22	2006/05/22	2043/12/31	\$525	5
YC48253		Active	Alex 122	Alexco Keno Hill Mining Corp. - 100%	2006/05/22	2006/05/22	2043/12/31	\$525	5
YC48254		Active	Alex 123	Alexco Keno Hill Mining Corp. - 100%	2006/05/22	2006/05/22	2043/12/31	\$525	5
YC48255		Active	Alex 124	Alexco Keno Hill Mining Corp. - 100%	2006/05/22	2006/05/22	2043/12/31	\$525	5
YC48256		Active	Alex 125	Alexco Keno Hill Mining Corp. - 100%	2006/05/22	2006/05/22	2043/12/31	\$525	5
YC48257		Active	Alex 126	Alexco Keno Hill Mining Corp. - 100%	2006/05/22	2006/05/22	2043/12/31	\$525	5
YC48258		Active	Alex 127	Alexco Keno Hill Mining Corp. - 100%	2006/05/22	2006/05/22	2043/12/31	\$525	5
YC48259		Active	Alex 128	Alexco Keno Hill Mining Corp. - 100%	2006/05/22	2006/05/22	2043/12/31	\$525	5
YC48260		Active	Alex 129	Alexco Keno Hill Mining Corp. - 100%	2006/05/22	2006/05/22	2043/12/31	\$525	5
YC48144		Active	Alex 13	Alexco Keno Hill Mining Corp. - 100%	2006/05/20	2006/06/02	2043/12/31	\$525	5
YC48261		Active	Alex 130	Alexco Keno Hill Mining Corp. - 100%	2006/05/22	2006/05/22	2043/12/31	\$525	5
YC48262		Active	Alex 131	Alexco Keno Hill Mining Corp. - 100%	2006/05/23	2006/06/02	2043/12/31	\$525	5
YC48263		Active	Alex 132	Alexco Keno Hill Mining Corp. - 100%	2006/05/23	2006/06/02	2043/12/31	\$525	5
YC48264		Active	Alex 133	Alexco Keno Hill Mining Corp. - 100%	2006/05/23	2006/06/02	2043/12/31	\$525	5
YC48265		Active	Alex 134	Alexco Keno Hill Mining Corp. - 100%	2006/05/23	2006/06/02	2043/12/31	\$525	5
YC48266		Active	Alex 135	Alexco Keno Hill Mining Corp. - 100%	2006/05/23	2006/06/02	2043/12/31	\$525	5
YC48267		Active	Alex 136	Alexco Keno Hill Mining Corp. - 100%	2006/05/23	2006/06/02	2043/12/31	\$525	5
YC48268		Active	Alex 137	Alexco Keno Hill Mining Corp. - 100%	2006/05/23	2006/06/02	2043/12/31	\$525	5
YC48269		Active	Alex 138	Alexco Keno Hill Mining Corp. - 100%	2006/05/23	2006/06/02	2043/12/31	\$525	5
YC48270		Active	Alex 139	Alexco Keno Hill Mining Corp. - 100%	2006/05/23	2006/06/02	2043/12/31	\$525	5
YC48145		Active	Alex 14	Alexco Keno Hill Mining Corp. - 100%	2006/05/20	2006/06/02	2043/12/31	\$525	5
YC48271		Active	Alex 140	Alexco Keno Hill Mining Corp. - 100%	2006/05/23	2006/06/02	2043/12/31	\$525	5
YC48272		Active	Alex 141	Alexco Keno Hill Mining Corp. - 100%	2006/05/23	2006/06/02	2043/12/31	\$525	5
YC48273		Active	Alex 142	Alexco Keno Hill Mining Corp. - 100%	2006/05/23	2006/06/02	2043/12/31	\$525	5
YC48274		Active	Alex 143	Alexco Keno Hill Mining Corp. - 100%	2006/05/23	2006/06/02	2043/12/31	\$525	5
YC48275		Active	Alex 144	Alexco Keno Hill Mining Corp. - 100%	2006/05/23	2006/06/02	2043/12/31	\$525	5
YC48276		Active	Alex 145	Alexco Keno Hill Mining Corp. - 100%	2006/05/23	2006/06/02	2043/12/31	\$525	5
YC48277		Active	Alex 146	Alexco Keno Hill Mining Corp. - 100%	2006/05/23	2006/06/02	2043/12/31	\$525	5
YC48278		Active	Alex 147	Alexco Keno Hill Mining Corp. - 100%	2006/05/23	2006/06/02	2043/12/31	\$525	5

Grant	Lease	Status	Claim Name	Owner	Staked	Recorded	Expiry	Renewal Cost per Term (CAD)	Term (Years)
YC48279		Active	Alex 148	Alexco Keno Hill Mining Corp. - 100%	2006/05/23	2006/06/02	2043/12/31	\$525	5
YC48280		Active	Alex 149	Alexco Keno Hill Mining Corp. - 100%	2006/05/15	2006/06/02	2043/12/31	\$525	5
YC48146		Active	Alex 15	Alexco Keno Hill Mining Corp. - 100%	2006/05/20	2006/06/02	2043/12/31	\$525	5
YC48281		Active	Alex 150	Alexco Keno Hill Mining Corp. - 100%	2006/05/15	2006/06/02	2043/12/31	\$525	5
YC48282		Active	Alex 151	Alexco Keno Hill Mining Corp. - 100%	2006/05/15	2006/06/02	2043/12/31	\$525	5
YC48283		Active	Alex 152	Alexco Keno Hill Mining Corp. - 100%	2006/05/15	2006/06/02	2043/12/31	\$525	5
YC48284		Active	Alex 153	Alexco Keno Hill Mining Corp. - 100%	2006/05/15	2006/06/02	2043/12/31	\$525	5
YC48285		Active	Alex 154	Alexco Keno Hill Mining Corp. - 100%	2006/05/15	2006/06/02	2043/12/31	\$525	5
YC48286		Active	Alex 155	Alexco Keno Hill Mining Corp. - 100%	2006/05/19	2006/06/02	2043/12/31	\$525	5
YC48287		Active	Alex 156	Alexco Keno Hill Mining Corp. - 100%	2006/05/19	2006/06/02	2043/12/31	\$525	5
YC48288		Active	Alex 157	Alexco Keno Hill Mining Corp. - 100%	2006/05/19	2006/06/02	2043/12/31	\$525	5
YC48289		Active	Alex 158	Alexco Keno Hill Mining Corp. - 100%	2006/05/19	2006/06/02	2043/12/31	\$525	5
YC48290		Active	Alex 159	Alexco Keno Hill Mining Corp. - 100%	2006/05/19	2006/06/02	2043/12/31	\$525	5
YC48147		Active	Alex 16	Alexco Keno Hill Mining Corp. - 100%	2006/05/20	2006/06/02	2043/12/31	\$525	5
YC48291		Active	Alex 160	Alexco Keno Hill Mining Corp. - 100%	2006/05/19	2006/06/02	2043/12/31	\$525	5
YC48292		Active	Alex 161	Alexco Keno Hill Mining Corp. - 100%	2006/05/19	2006/06/02	2043/12/31	\$525	5
YC48293		Active	Alex 162	Alexco Keno Hill Mining Corp. - 100%	2006/05/19	2006/06/02	2043/12/31	\$525	5
YC48294		Active	Alex 163	Alexco Keno Hill Mining Corp. - 100%	2006/05/19	2006/06/02	2043/12/31	\$525	5
YC48295		Active	Alex 164	Alexco Keno Hill Mining Corp. - 100%	2006/05/19	2006/06/02	2042/12/31	\$525	5
YC48296		Active	Alex 165	Alexco Keno Hill Mining Corp. - 100%	2006/05/19	2006/06/02	2042/12/31	\$525	5
YC48297		Active	Alex 166	Alexco Keno Hill Mining Corp. - 100%	2006/05/19	2006/06/02	2042/12/31	\$525	5
YC48298		Active	Alex 167	Alexco Keno Hill Mining Corp. - 100%	2006/05/19	2006/06/02	2042/12/31	\$525	5
YC48299		Active	Alex 168	Alexco Keno Hill Mining Corp. - 100%	2006/05/19	2006/06/02	2042/12/31	\$525	5
YC48300		Active	Alex 169	Alexco Keno Hill Mining Corp. - 100%	2006/05/19	2006/06/02	2042/12/31	\$525	5
YC48148		Active	Alex 17	Alexco Keno Hill Mining Corp. - 100%	2006/05/26	2006/06/02	2043/12/31	\$525	5
YC48301		Active	Alex 170	Alexco Keno Hill Mining Corp. - 100%	2006/05/19	2006/06/02	2042/12/31	\$525	5
YC48302		Active	Alex 171	Alexco Keno Hill Mining Corp. - 100%	2006/05/19	2006/06/02	2042/12/31	\$525	5
YC48303		Active	Alex 172	Alexco Keno Hill Mining Corp. - 100%	2006/05/19	2006/06/02	2042/12/31	\$525	5
YC48304		Active	Alex 173	Alexco Keno Hill Mining Corp. - 100%	2006/05/19	2006/06/02	2042/12/31	\$525	5

Grant	Lease	Status	Claim Name	Owner	Staked	Recorded	Expiry	Renewal Cost per Term (CAD)	Term (Years)
YC48305		Active	Alex 174	Alexco Keno Hill Mining Corp. - 100%	2006/05/19	2006/06/02	2042/12/31	\$525	5
YC48306		Active	Alex 175	Alexco Keno Hill Mining Corp. - 100%	2006/05/19	2006/06/02	2046/12/31	\$525	5
YC48307		Active	Alex 176	Alexco Keno Hill Mining Corp. - 100%	2006/05/19	2006/06/02	2046/12/31	\$525	5
YC48308		Active	Alex 177	Alexco Keno Hill Mining Corp. - 100%	2006/05/19	2006/06/02	2042/12/31	\$525	5
YC48309		Active	Alex 178	Alexco Keno Hill Mining Corp. - 100%	2006/05/19	2006/06/02	2042/12/31	\$525	5
YC48310		Active	Alex 179	Alexco Keno Hill Mining Corp. - 100%	2006/05/21	2006/06/02	2043/12/31	\$525	5
YC48149		Active	Alex 18	Alexco Keno Hill Mining Corp. - 100%	2006/05/21	2006/06/02	2043/12/31	\$525	5
YC48311		Active	Alex 180	Alexco Keno Hill Mining Corp. - 100%	2006/05/21	2006/06/02	2043/12/31	\$525	5
YC48312		Active	Alex 181	Alexco Keno Hill Mining Corp. - 100%	2006/05/21	2006/06/02	2043/12/31	\$525	5
YC48313		Active	Alex 182	Alexco Keno Hill Mining Corp. - 100%	2006/05/21	2006/06/02	2043/12/31	\$525	5
YC48314		Active	Alex 183	Alexco Keno Hill Mining Corp. - 100%	2006/05/21	2006/06/02	2043/12/31	\$525	5
YC48315		Active	Alex 184	Alexco Keno Hill Mining Corp. - 100%	2006/05/21	2006/06/02	2043/12/31	\$525	5
YC48316		Active	Alex 185	Alexco Keno Hill Mining Corp. - 100%	2006/05/21	2006/06/02	2043/12/31	\$525	5
YC48317		Active	Alex 186	Alexco Keno Hill Mining Corp. - 100%	2006/05/21	2006/06/02	2043/12/31	\$525	5
YC48318		Active	Alex 187	Alexco Keno Hill Mining Corp. - 100%	2006/05/16	2006/06/02	2043/12/31	\$525	5
YC48319		Active	Alex 188	Alexco Keno Hill Mining Corp. - 100%	2006/05/16	2006/06/02	2043/12/31	\$525	5
YC48320		Active	Alex 189	Alexco Keno Hill Mining Corp. - 100%	2006/05/16	2006/06/02	2043/12/31	\$525	5
YC48150		Active	Alex 19	Alexco Keno Hill Mining Corp. - 100%	2006/05/21	2006/06/02	2043/12/31	\$525	5
YC48321		Active	Alex 190	Alexco Keno Hill Mining Corp. - 100%	2006/05/16	2006/06/02	2043/12/31	\$525	5
YC48322		Active	Alex 191	Alexco Keno Hill Mining Corp. - 100%	2006/05/16	2006/06/02	2043/12/31	\$525	5
YC48323		Active	Alex 192	Alexco Keno Hill Mining Corp. - 100%	2006/05/16	2006/06/02	2043/12/31	\$525	5
YC48324		Active	Alex 193	Alexco Keno Hill Mining Corp. - 100%	2006/05/16	2006/06/02	2043/12/31	\$525	5
YC48325		Active	Alex 194	Alexco Keno Hill Mining Corp. - 100%	2006/05/16	2006/06/02	2043/12/31	\$525	5
YC48326		Active	Alex 195	Alexco Keno Hill Mining Corp. - 100%	2006/05/17	2006/06/02	2043/12/31	\$525	5
YC48327		Active	Alex 196	Alexco Keno Hill Mining Corp. - 100%	2006/05/17	2006/06/02	2043/12/31	\$525	5
YC48328		Active	Alex 197	Alexco Keno Hill Mining Corp. - 100%	2006/05/17	2006/06/02	2043/12/31	\$525	5
YC48329		Active	Alex 198	Alexco Keno Hill Mining Corp. - 100%	2006/05/17	2006/06/02	2043/12/31	\$525	5
YC48330		Active	Alex 199	Alexco Keno Hill Mining Corp. - 100%	2006/05/17	2006/06/02	2043/12/31	\$525	5
YC48133		Active	Alex 2	Alexco Keno Hill Mining Corp. - 100%	2006/05/26	2006/06/02	2043/12/31	\$525	5

Grant	Lease	Status	Claim Name	Owner	Staked	Recorded	Expiry	Renewal Cost per Term (CAD)	Term (Years)
YC48151		Active	Alex 20	Alexco Keno Hill Mining Corp. - 100%	2006/05/21	2006/06/02	2043/12/31	\$525	5
YC48331		Active	Alex 200	Alexco Keno Hill Mining Corp. - 100%	2006/05/17	2006/06/02	2043/12/31	\$525	5
YC48332		Active	Alex 201	Alexco Keno Hill Mining Corp. - 100%	2006/05/17	2006/06/02	2043/12/31	\$525	5
YC48333		Active	Alex 202	Alexco Keno Hill Mining Corp. - 100%	2006/05/17	2006/06/02	2043/12/31	\$525	5
YC48334		Active	Alex 203	Alexco Keno Hill Mining Corp. - 100%	2006/05/17	2006/06/02	2043/12/31	\$525	5
YC48335		Active	Alex 204	Alexco Keno Hill Mining Corp. - 100%	2006/05/17	2006/06/02	2043/12/31	\$525	5
YC48336		Active	Alex 205	Alexco Keno Hill Mining Corp. - 100%	2006/05/17	2006/06/02	2043/12/31	\$525	5
YC48337		Active	Alex 206	Alexco Keno Hill Mining Corp. - 100%	2006/05/17	2006/06/02	2043/12/31	\$525	5
YC48338		Active	Alex 207	Alexco Keno Hill Mining Corp. - 100%	2006/05/17	2006/06/02	2043/12/31	\$525	5
YC48548		Active	Alex 208	Alexco Keno Hill Mining Corp. - 100%	2006/05/17	2006/06/02	2043/12/31	\$525	5
YC48339		Active	Alex 209	Alexco Keno Hill Mining Corp. - 100%	2006/05/18	2006/06/02	2043/12/31	\$525	5
YC48152		Active	Alex 21	Alexco Keno Hill Mining Corp. - 100%	2006/05/21	2006/06/02	2043/12/31	\$525	5
YC48340		Active	Alex 210	Alexco Keno Hill Mining Corp. - 100%	2006/05/18	2006/06/02	2043/12/31	\$525	5
YC48341		Active	Alex 211	Alexco Keno Hill Mining Corp. - 100%	2006/05/18	2006/06/02	2043/12/31	\$525	5
YC48342		Active	Alex 212	Alexco Keno Hill Mining Corp. - 100%	2006/05/18	2006/06/02	2043/12/31	\$525	5
YC48343		Active	Alex 213	Alexco Keno Hill Mining Corp. - 100%	2006/05/18	2006/06/02	2043/12/31	\$525	5
YC48344		Active	Alex 214	Alexco Keno Hill Mining Corp. - 100%	2006/05/18	2006/06/02	2043/12/31	\$525	5
YC48345		Active	Alex 215	Alexco Keno Hill Mining Corp. - 100%	2006/05/18	2006/06/02	2043/12/31	\$525	5
YC48346		Active	Alex 216	Alexco Keno Hill Mining Corp. - 100%	2006/05/18	2006/06/02	2043/12/31	\$525	5
YC48347		Active	Alex 217	Alexco Keno Hill Mining Corp. - 100%	2006/05/18	2006/06/02	2043/12/31	\$525	5
YC48348		Active	Alex 218	Alexco Keno Hill Mining Corp. - 100%	2006/05/18	2006/06/02	2043/12/31	\$525	5
YC48349		Active	Alex 219	Alexco Keno Hill Mining Corp. - 100%	2006/05/18	2006/06/02	2043/12/31	\$525	5
YC48153		Active	Alex 22	Alexco Keno Hill Mining Corp. - 100%	2006/05/21	2006/06/02	2043/12/31	\$525	5
YC48350		Active	Alex 220	Alexco Keno Hill Mining Corp. - 100%	2006/05/18	2006/06/02	2043/12/31	\$525	5
YC48351		Active	Alex 221	Alexco Keno Hill Mining Corp. - 100%	2006/05/24	2006/06/02	2043/12/31	\$525	5
YC48352		Active	Alex 222	Alexco Keno Hill Mining Corp. - 100%	2006/05/19	2006/06/02	2043/12/31	\$525	5
YC48353		Active	Alex 223	Alexco Keno Hill Mining Corp. - 100%	2006/05/24	2006/06/02	2043/12/31	\$525	5
YC48354		Active	Alex 224	Alexco Keno Hill Mining Corp. - 100%	2006/05/24	2006/06/02	2043/12/31	\$525	5
YC48355		Active	Alex 225	Alexco Keno Hill Mining Corp. - 100%	2006/05/24	2006/06/02	2043/12/31	\$525	5

Grant	Lease	Status	Claim Name	Owner	Staked	Recorded	Expiry	Renewal Cost per Term (CAD)	Term (Years)
YC48356		Active	Alex 226	Alexco Keno Hill Mining Corp. - 100%	2006/05/24	2006/06/02	2043/12/31	\$525	5
YC48357		Active	Alex 227	Alexco Keno Hill Mining Corp. - 100%	2006/05/18	2006/06/02	2043/12/31	\$525	5
YC48358		Active	Alex 228	Alexco Keno Hill Mining Corp. - 100%	2006/05/18	2006/06/02	2043/12/31	\$525	5
YC48359		Active	Alex 229	Alexco Keno Hill Mining Corp. - 100%	2006/05/18	2006/06/02	2042/12/31	\$525	5
YC48154		Active	Alex 23	Alexco Keno Hill Mining Corp. - 100%	2006/05/21	2006/06/02	2043/12/31	\$525	5
YC48360		Active	Alex 230	Alexco Keno Hill Mining Corp. - 100%	2006/05/18	2006/06/02	2042/12/31	\$525	5
YC48361		Active	Alex 231	Alexco Keno Hill Mining Corp. - 100%	2006/05/18	2006/06/02	2042/12/31	\$525	5
YC48362		Active	Alex 232	Alexco Keno Hill Mining Corp. - 100%	2006/05/18	2006/06/02	2042/12/31	\$525	5
YC48363		Active	Alex 233	Alexco Keno Hill Mining Corp. - 100%	2006/05/18	2006/06/02	2042/12/31	\$525	5
YC48364		Active	Alex 234	Alexco Keno Hill Mining Corp. - 100%	2006/05/18	2006/06/02	2042/12/31	\$525	5
YC48365		Active	Alex 235	Alexco Keno Hill Mining Corp. - 100%	2006/05/18	2006/06/02	2042/12/31	\$525	5
YC48366		Active	Alex 236	Alexco Keno Hill Mining Corp. - 100%	2006/05/18	2006/06/02	2042/12/31	\$525	5
YC48367		Active	Alex 237	Alexco Keno Hill Mining Corp. - 100%	2006/05/19	2006/06/02	2042/12/31	\$525	5
YC48368		Active	Alex 238	Alexco Keno Hill Mining Corp. - 100%	2006/05/19	2006/06/02	2042/12/31	\$525	5
YC48369		Active	Alex 239	Alexco Keno Hill Mining Corp. - 100%	2006/05/19	2006/06/02	2042/12/31	\$525	5
YC48155		Active	Alex 24	Alexco Keno Hill Mining Corp. - 100%	2006/05/21	2006/06/02	2043/12/31	\$525	5
YC48370		Active	Alex 240	Alexco Keno Hill Mining Corp. - 100%	2006/05/19	2006/06/02	2042/12/31	\$525	5
YC48371		Active	Alex 241	Alexco Keno Hill Mining Corp. - 100%	2006/05/19	2006/06/02	2042/12/31	\$525	5
YC48372		Active	Alex 242	Alexco Keno Hill Mining Corp. - 100%	2006/05/19	2006/06/02	2042/12/31	\$525	5
YC48373		Active	Alex 243	Alexco Keno Hill Mining Corp. - 100%	2006/05/19	2006/06/02	2042/12/31	\$525	5
YC48374		Active	Alex 244	Alexco Keno Hill Mining Corp. - 100%	2006/05/19	2006/06/02	2042/12/31	\$525	5
YC48375		Active	Alex 245	Alexco Keno Hill Mining Corp. - 100%	2006/05/19	2006/06/02	2042/12/31	\$525	5
YC48376		Active	Alex 246	Alexco Keno Hill Mining Corp. - 100%	2006/05/19	2006/06/02	2042/12/31	\$525	5
YC48377		Active	Alex 247	Alexco Keno Hill Mining Corp. - 100%	2006/05/19	2006/06/02	2042/12/31	\$525	5
YC48378		Active	Alex 248	Alexco Keno Hill Mining Corp. - 100%	2006/05/19	2006/06/02	2042/12/31	\$525	5
YC48379		Active	Alex 249	Alexco Keno Hill Mining Corp. - 100%	2006/05/19	2006/06/02	2042/12/31	\$525	5
YC48156		Active	Alex 25	Alexco Keno Hill Mining Corp. - 100%	2006/05/21	2006/06/02	2043/12/31	\$525	5
YC48380		Active	Alex 250	Alexco Keno Hill Mining Corp. - 100%	2006/05/19	2006/06/02	2042/12/31	\$525	5
YC48381		Active	Alex 251	Alexco Keno Hill Mining Corp. - 100%	2006/05/20	2006/06/02	2042/12/31	\$525	5

Grant	Lease	Status	Claim Name	Owner	Staked	Recorded	Expiry	Renewal Cost per Term (CAD)	Term (Years)
YC48382		Active	Alex 252	Alexco Keno Hill Mining Corp. - 100%	2006/05/20	2006/06/02	2042/12/31	\$525	5
YC48383		Active	Alex 253	Alexco Keno Hill Mining Corp. - 100%	2006/05/20	2006/06/02	2042/12/31	\$525	5
YC48384		Active	Alex 254	Alexco Keno Hill Mining Corp. - 100%	2006/05/20	2006/06/02	2042/12/31	\$525	5
YC48385		Active	Alex 255	Alexco Keno Hill Mining Corp. - 100%	2006/05/20	2006/06/02	2042/12/31	\$525	5
YC48386		Active	Alex 256	Alexco Keno Hill Mining Corp. - 100%	2006/05/20	2006/06/02	2042/12/31	\$525	5
YC48387		Active	Alex 257	Alexco Keno Hill Mining Corp. - 100%	2006/05/20	2006/06/02	2042/12/31	\$525	5
YC48388		Active	Alex 258	Alexco Keno Hill Mining Corp. - 100%	2006/05/20	2006/06/02	2042/12/31	\$525	5
YC48389		Active	Alex 259	Alexco Keno Hill Mining Corp. - 100%	2006/05/21	2006/06/02	2042/12/31	\$525	5
YC48157		Active	Alex 26	Alexco Keno Hill Mining Corp. - 100%	2006/05/21	2006/06/02	2043/12/31	\$525	5
YC48390		Active	Alex 260	Alexco Keno Hill Mining Corp. - 100%	2006/05/21	2006/06/02	2042/12/31	\$525	5
YC48391		Active	Alex 261	Alexco Keno Hill Mining Corp. - 100%	2006/05/21	2006/06/02	2042/12/31	\$525	5
YC48392		Active	Alex 262	Alexco Keno Hill Mining Corp. - 100%	2006/05/21	2006/06/02	2042/12/31	\$525	5
YC48393		Active	Alex 263	Alexco Keno Hill Mining Corp. - 100%	2006/05/21	2006/06/02	2042/12/31	\$525	5
YC48549		Active	Alex 264	Alexco Keno Hill Mining Corp. - 100%	2006/05/21	2006/06/02	2042/12/31	\$525	5
YC48394		Active	Alex 265	Alexco Keno Hill Mining Corp. - 100%	2006/05/19	2006/06/02	2042/12/31	\$525	5
YC48395		Active	Alex 266	Alexco Keno Hill Mining Corp. - 100%	2006/05/19	2006/06/02	2042/12/31	\$525	5
YC48396		Active	Alex 267	Alexco Keno Hill Mining Corp. - 100%	2006/05/19	2006/06/02	2042/12/31	\$525	5
YC48397		Active	Alex 268	Alexco Keno Hill Mining Corp. - 100%	2006/05/19	2006/06/02	2042/12/31	\$525	5
YC48398		Active	Alex 269	Alexco Keno Hill Mining Corp. - 100%	2006/05/19	2006/06/02	2042/12/31	\$525	5
YC48158		Active	Alex 27	Alexco Keno Hill Mining Corp. - 100%	2006/05/21	2006/06/02	2043/12/31	\$525	5
YC48399		Active	Alex 270	Alexco Keno Hill Mining Corp. - 100%	2006/05/19	2006/06/02	2042/12/31	\$525	5
YC48400		Active	Alex 271	Alexco Keno Hill Mining Corp. - 100%	2006/05/19	2006/06/02	2042/12/31	\$525	5
YC48401		Active	Alex 272	Alexco Keno Hill Mining Corp. - 100%	2006/05/19	2006/06/02	2042/12/31	\$525	5
YC48402		Active	Alex 273	Alexco Keno Hill Mining Corp. - 100%	2006/05/19	2006/06/02	2042/12/31	\$525	5
YC48403		Active	Alex 274	Alexco Keno Hill Mining Corp. - 100%	2006/05/19	2006/06/02	2042/12/31	\$525	5
YC48404		Active	Alex 275	Alexco Keno Hill Mining Corp. - 100%	2006/05/19	2006/06/02	2042/12/31	\$525	5
YC48405		Active	Alex 276	Alexco Keno Hill Mining Corp. - 100%	2006/05/19	2006/06/02	2042/12/31	\$525	5
YC48406		Active	Alex 277	Alexco Keno Hill Mining Corp. - 100%	2006/05/19	2006/06/02	2046/12/31	\$525	5
YC48407		Active	Alex 278	Alexco Keno Hill Mining Corp. - 100%	2006/05/19	2006/06/02	2046/12/31	\$525	5

Grant	Lease	Status	Claim Name	Owner	Staked	Recorded	Expiry	Renewal Cost per Term (CAD)	Term (Years)
YC48408		Active	Alex 279	Alexco Keno Hill Mining Corp. - 100%	2006/05/19	2006/06/02	2046/12/31	\$525	5
YC48159		Active	Alex 28	Alexco Keno Hill Mining Corp. - 100%	2006/05/21	2006/06/02	2043/12/31	\$525	5
YC48409		Active	Alex 280	Alexco Keno Hill Mining Corp. - 100%	2006/05/19	2006/06/02	2046/12/31	\$525	5
YC48410		Active	Alex 287	Alexco Keno Hill Mining Corp. - 100%	2006/05/23	2006/06/02	2043/12/31	\$525	5
YC48411		Active	Alex 288	Alexco Keno Hill Mining Corp. - 100%	2006/05/23	2006/06/02	2043/12/31	\$525	5
YC48412		Active	Alex 289	Alexco Keno Hill Mining Corp. - 100%	2006/05/23	2006/06/02	2043/12/31	\$525	5
YC48160		Active	Alex 29	Alexco Keno Hill Mining Corp. - 100%	2006/05/21	2006/06/02	2043/12/31	\$525	5
YC48413		Active	Alex 290	Alexco Keno Hill Mining Corp. - 100%	2006/05/23	2006/06/02	2043/12/31	\$525	5
YC48414		Active	Alex 291	Alexco Keno Hill Mining Corp. - 100%	2006/05/23	2006/06/02	2043/12/31	\$525	5
YC48415		Active	Alex 292	Alexco Keno Hill Mining Corp. - 100%	2006/05/23	2006/06/02	2043/12/31	\$525	5
YC48416		Active	Alex 293	Alexco Keno Hill Mining Corp. - 100%	2006/05/23	2006/06/02	2043/12/31	\$525	5
YC48417		Active	Alex 294	Alexco Keno Hill Mining Corp. - 100%	2006/05/23	2006/06/02	2043/12/31	\$525	5
YC48418		Active	Alex 295	Alexco Keno Hill Mining Corp. - 100%	2006/05/16	2006/06/02	2043/12/31	\$525	5
YC48419		Active	Alex 296	Alexco Keno Hill Mining Corp. - 100%	2006/05/16	2006/06/02	2043/12/31	\$525	5
YC48420		Active	Alex 297	Alexco Keno Hill Mining Corp. - 100%	2006/05/16	2006/06/02	2043/12/31	\$525	5
YC48421		Active	Alex 298	Alexco Keno Hill Mining Corp. - 100%	2006/05/16	2006/06/02	2043/12/31	\$525	5
YC48422		Active	Alex 299	Alexco Keno Hill Mining Corp. - 100%	2006/05/16	2006/06/02	2043/12/31	\$525	5
YC48134		Active	Alex 3	Alexco Keno Hill Mining Corp. - 100%	2006/05/26	2006/06/02	2043/12/31	\$525	5
YC48161		Active	Alex 30	Alexco Keno Hill Mining Corp. - 100%	2006/05/21	2006/06/02	2043/12/31	\$525	5
YC48423		Active	Alex 300	Alexco Keno Hill Mining Corp. - 100%	2006/05/16	2006/06/02	2043/12/31	\$525	5
YC48424		Active	Alex 301	Alexco Keno Hill Mining Corp. - 100%	2006/05/17	2006/06/02	2043/12/31	\$525	5
YC48425		Active	Alex 302	Alexco Keno Hill Mining Corp. - 100%	2006/05/17	2006/06/02	2043/12/31	\$525	5
YC48426		Active	Alex 303	Alexco Keno Hill Mining Corp. - 100%	2006/05/17	2006/06/02	2043/12/31	\$525	5
YC48427		Active	Alex 304	Alexco Keno Hill Mining Corp. - 100%	2006/05/17	2006/06/02	2043/12/31	\$525	5
YC48428		Active	Alex 305	Alexco Keno Hill Mining Corp. - 100%	2006/05/17	2006/06/02	2043/12/31	\$525	5
YC48429		Active	Alex 306	Alexco Keno Hill Mining Corp. - 100%	2006/05/17	2006/06/02	2043/12/31	\$525	5
YC48430		Active	Alex 307	Alexco Keno Hill Mining Corp. - 100%	2006/05/17	2006/06/02	2043/12/31	\$525	5
YC48431		Active	Alex 308	Alexco Keno Hill Mining Corp. - 100%	2006/05/17	2006/06/02	2043/12/31	\$525	5
YC48432		Active	Alex 309	Alexco Keno Hill Mining Corp. - 100%	2006/05/17	2006/06/02	2043/12/31	\$525	5

Grant	Lease	Status	Claim Name	Owner	Staked	Recorded	Expiry	Renewal Cost per Term (CAD)	Term (Years)
YC48162		Active	Alex 31	Alexco Keno Hill Mining Corp. - 100%	2006/05/21	2006/06/02	2043/12/31	\$525	5
YC48433		Active	Alex 310	Alexco Keno Hill Mining Corp. - 100%	2006/05/17	2006/06/02	2043/12/31	\$525	5
YC48434		Active	Alex 311	Alexco Keno Hill Mining Corp. - 100%	2006/05/17	2006/06/02	2043/12/31	\$525	5
YC48435		Active	Alex 312	Alexco Keno Hill Mining Corp. - 100%	2006/05/17	2006/06/02	2043/12/31	\$525	5
YC48436		Active	Alex 313	Alexco Keno Hill Mining Corp. - 100%	2006/05/16	2006/06/02	2043/12/31	\$525	5
YC48437		Active	Alex 314	Alexco Keno Hill Mining Corp. - 100%	2006/05/16	2006/06/02	2043/12/31	\$525	5
YC48438		Active	Alex 315	Alexco Keno Hill Mining Corp. - 100%	2006/05/16	2006/06/02	2043/12/31	\$525	5
YC48439		Active	Alex 316	Alexco Keno Hill Mining Corp. - 100%	2006/05/16	2006/06/02	2043/12/31	\$525	5
YC48440		Active	Alex 317	Alexco Keno Hill Mining Corp. - 100%	2006/05/16	2006/06/02	2043/12/31	\$525	5
YC48441		Active	Alex 318	Alexco Keno Hill Mining Corp. - 100%	2006/05/16	2006/06/02	2043/12/31	\$525	5
YC48442		Active	Alex 319	Alexco Keno Hill Mining Corp. - 100%	2006/05/16	2006/06/02	2043/12/31	\$525	5
YC48163		Active	Alex 32	Alexco Keno Hill Mining Corp. - 100%	2006/05/21	2006/06/02	2043/12/31	\$525	5
YC48443		Active	Alex 320	Alexco Keno Hill Mining Corp. - 100%	2006/05/16	2006/06/02	2043/12/31	\$525	5
YC48444		Active	Alex 321	Alexco Keno Hill Mining Corp. - 100%	2006/05/16	2006/06/02	2043/12/31	\$525	5
YC48445		Active	Alex 322	Alexco Keno Hill Mining Corp. - 100%	2006/05/16	2006/06/02	2043/12/31	\$525	5
YC48446		Active	Alex 323	Alexco Keno Hill Mining Corp. - 100%	2006/05/16	2006/06/02	2043/12/31	\$525	5
YC48447		Active	Alex 324	Alexco Keno Hill Mining Corp. - 100%	2006/05/16	2006/06/02	2043/12/31	\$525	5
YC48448		Active	Alex 325	Alexco Keno Hill Mining Corp. - 100%	2006/05/16	2006/06/02	2043/12/31	\$525	5
YC48449		Active	Alex 326	Alexco Keno Hill Mining Corp. - 100%	2006/05/16	2006/06/02	2043/12/31	\$525	5
YC48450		Active	Alex 327	Alexco Keno Hill Mining Corp. - 100%	2006/05/19	2006/06/02	2043/12/31	\$525	5
YC48451		Active	Alex 328	Alexco Keno Hill Mining Corp. - 100%	2006/05/16	2006/06/02	2043/12/31	\$525	5
YC48452		Active	Alex 329	Alexco Keno Hill Mining Corp. - 100%	2006/05/17	2006/06/02	2043/12/31	\$525	5
YC48164		Active	Alex 33	Alexco Keno Hill Mining Corp. - 100%	2006/05/23	2006/06/02	2043/12/31	\$525	5
YC48453		Active	Alex 330	Alexco Keno Hill Mining Corp. - 100%	2006/05/17	2006/06/02	2043/12/31	\$525	5
YC48454		Active	Alex 331	Alexco Keno Hill Mining Corp. - 100%	2006/05/17	2006/06/02	2043/12/31	\$525	5
YC48455		Active	Alex 332	Alexco Keno Hill Mining Corp. - 100%	2006/05/17	2006/06/02	2043/12/31	\$525	5
YC48456		Active	Alex 333	Alexco Keno Hill Mining Corp. - 100%	2006/05/17	2006/06/02	2042/12/31	\$525	5
YC48457		Active	Alex 334	Alexco Keno Hill Mining Corp. - 100%	2006/05/17	2006/06/02	2042/12/31	\$525	5
YC48458		Active	Alex 335	Alexco Keno Hill Mining Corp. - 100%	2006/05/17	2006/06/02	2042/12/31	\$525	5

Grant	Lease	Status	Claim Name	Owner	Staked	Recorded	Expiry	Renewal Cost per Term (CAD)	Term (Years)
YC48459		Active	Alex 336	Alexco Keno Hill Mining Corp. - 100%	2006/05/17	2006/06/02	2042/12/31	\$525	5
YC48460		Active	Alex 337	Alexco Keno Hill Mining Corp. - 100%	2006/05/17	2006/06/02	2042/12/31	\$525	5
YC48461		Active	Alex 338	Alexco Keno Hill Mining Corp. - 100%	2006/05/17	2006/06/02	2042/12/31	\$525	5
YC48462		Active	Alex 339	Alexco Keno Hill Mining Corp. - 100%	2006/05/17	2006/06/02	2042/12/31	\$525	5
YC48165		Active	Alex 34	Alexco Keno Hill Mining Corp. - 100%	2006/05/23	2006/06/02	2043/12/31	\$525	5
YC48463		Active	Alex 340	Alexco Keno Hill Mining Corp. - 100%	2006/05/17	2006/06/02	2042/12/31	\$525	5
YC48464		Active	Alex 341	Alexco Keno Hill Mining Corp. - 100%	2006/05/17	2006/06/02	2042/12/31	\$525	5
YC48465		Active	Alex 342	Alexco Keno Hill Mining Corp. - 100%	2006/05/17	2006/06/02	2042/12/31	\$525	5
YC48466		Active	Alex 343	Alexco Keno Hill Mining Corp. - 100%	2006/05/21	2006/06/02	2042/12/31	\$525	5
YC48467		Active	Alex 344	Alexco Keno Hill Mining Corp. - 100%	2006/05/21	2006/06/02	2042/12/31	\$525	5
YC48468		Active	Alex 345	Alexco Keno Hill Mining Corp. - 100%	2006/05/21	2006/06/02	2042/12/31	\$525	5
YC48469		Active	Alex 346	Alexco Keno Hill Mining Corp. - 100%	2006/05/21	2006/06/02	2042/12/31	\$525	5
YC48470		Active	Alex 347	Alexco Keno Hill Mining Corp. - 100%	2006/05/21	2006/06/02	2042/12/31	\$525	5
YC48471		Active	Alex 348	Alexco Keno Hill Mining Corp. - 100%	2006/05/15	2006/06/02	2042/12/31	\$525	5
YC48472		Active	Alex 349	Alexco Keno Hill Mining Corp. - 100%	2006/05/15	2006/06/02	2042/12/31	\$525	5
YC48166		Active	Alex 35	Alexco Keno Hill Mining Corp. - 100%	2006/05/23	2006/06/02	2043/12/31	\$525	5
YC48473		Active	Alex 350	Alexco Keno Hill Mining Corp. - 100%	2006/05/15	2006/06/02	2042/12/31	\$525	5
YC48474		Active	Alex 351	Alexco Keno Hill Mining Corp. - 100%	2006/05/15	2006/06/02	2042/12/31	\$525	5
YC48475		Active	Alex 352	Alexco Keno Hill Mining Corp. - 100%	2006/05/15	2006/06/02	2042/12/31	\$525	5
YC48476		Active	Alex 353	Alexco Keno Hill Mining Corp. - 100%	2006/05/20	2006/06/02	2042/12/31	\$525	5
YC48477		Active	Alex 354	Alexco Keno Hill Mining Corp. - 100%	2006/05/15	2006/06/02	2042/12/31	\$525	5
YC48478		Active	Alex 355	Alexco Keno Hill Mining Corp. - 100%	2006/05/20	2006/06/02	2042/12/31	\$525	5
YC48479		Active	Alex 356	Alexco Keno Hill Mining Corp. - 100%	2006/05/15	2006/06/02	2042/12/31	\$525	5
YC48480		Active	Alex 357	Alexco Keno Hill Mining Corp. - 100%	2006/05/20	2006/06/02	2042/12/31	\$525	5
YC48481		Active	Alex 358	Alexco Keno Hill Mining Corp. - 100%	2006/05/20	2006/06/02	2042/12/31	\$525	5
YC48482		Active	Alex 359	Alexco Keno Hill Mining Corp. - 100%	2006/05/23	2006/06/02	2042/12/31	\$525	5
YC48167		Active	Alex 36	Alexco Keno Hill Mining Corp. - 100%	2006/05/23	2006/06/02	2043/12/31	\$525	5
YC48483		Active	Alex 360	Alexco Keno Hill Mining Corp. - 100%	2006/05/23	2006/06/02	2042/12/31	\$525	5
YC48484		Active	Alex 361	Alexco Keno Hill Mining Corp. - 100%	2006/05/23	2006/06/02	2042/12/31	\$525	5

Grant	Lease	Status	Claim Name	Owner	Staked	Recorded	Expiry	Renewal Cost per Term (CAD)	Term (Years)
YC48485		Active	Alex 362	Alexco Keno Hill Mining Corp. - 100%	2006/05/23	2006/06/02	2042/12/31	\$525	5
YC48486		Active	Alex 363	Alexco Keno Hill Mining Corp. - 100%	2006/05/23	2006/06/02	2042/12/31	\$525	5
YC48487		Active	Alex 364	Alexco Keno Hill Mining Corp. - 100%	2006/05/23	2006/06/02	2042/12/31	\$525	5
YC48488		Active	Alex 365	Alexco Keno Hill Mining Corp. - 100%	2006/05/23	2006/06/02	2042/12/31	\$525	5
YC48489		Active	Alex 366	Alexco Keno Hill Mining Corp. - 100%	2006/05/23	2006/06/02	2042/12/31	\$525	5
YC48490		Active	Alex 367	Alexco Keno Hill Mining Corp. - 100%	2006/05/23	2006/06/02	2042/12/31	\$525	5
YC48491		Active	Alex 368	Alexco Keno Hill Mining Corp. - 100%	2006/05/23	2006/06/02	2042/12/31	\$525	5
YC48492		Active	Alex 369	Alexco Keno Hill Mining Corp. - 100%	2006/05/23	2006/06/02	2042/12/31	\$525	5
YC48168		Active	Alex 37	Alexco Keno Hill Mining Corp. - 100%	2006/05/15	2006/06/02	2043/12/31	\$525	5
YC48493		Active	Alex 371	Alexco Keno Hill Mining Corp. - 100%	2006/05/23	2006/06/02	2042/12/31	\$525	5
YC48494		Active	Alex 372	Alexco Keno Hill Mining Corp. - 100%	2006/05/23	2006/06/02	2042/12/31	\$525	5
YC48495		Active	Alex 373	Alexco Keno Hill Mining Corp. - 100%	2006/05/23	2006/06/02	2042/12/31	\$525	5
YC48496		Active	Alex 374	Alexco Keno Hill Mining Corp. - 100%	2006/05/23	2006/06/02	2042/12/31	\$525	5
YC48497		Active	Alex 375	Alexco Keno Hill Mining Corp. - 100%	2006/05/23	2006/06/02	2042/12/31	\$525	5
YC48498		Active	Alex 376	Alexco Keno Hill Mining Corp. - 100%	2006/06/02	2006/06/02	2042/12/31	\$525	5
YC48499		Active	Alex 377	Alexco Keno Hill Mining Corp. - 100%	2006/05/23	2006/06/02	2046/12/31	\$525	5
YC48500		Active	Alex 379	Alexco Keno Hill Mining Corp. - 100%	2006/05/23	2006/06/02	2042/12/31	\$525	5
YC48169		Active	Alex 38	Alexco Keno Hill Mining Corp. - 100%	2006/05/15	2006/06/02	2043/12/31	\$525	5
YC48501		Active	Alex 380	Alexco Keno Hill Mining Corp. - 100%	2006/05/23	2006/06/02	2042/12/31	\$525	5
YC48502		Active	Alex 381	Alexco Keno Hill Mining Corp. - 100%	2006/05/23	2006/06/02	2042/12/31	\$525	5
YC48503		Active	Alex 382	Alexco Keno Hill Mining Corp. - 100%	2006/05/23	2006/06/02	2042/12/31	\$525	5
YC48504		Active	Alex 383	Alexco Keno Hill Mining Corp. - 100%	2006/05/24	2006/06/02	2042/12/31	\$525	5
YC48505		Active	Alex 384	Alexco Keno Hill Mining Corp. - 100%	2006/05/24	2006/06/02	2042/12/31	\$525	5
YC48506		Active	Alex 386	Alexco Keno Hill Mining Corp. - 100%	2006/05/24	2006/06/02	2042/12/31	\$525	5
YC48170		Active	Alex 39	Alexco Keno Hill Mining Corp. - 100%	2006/05/15	2006/06/02	2043/12/31	\$525	5
YC48135		Active	Alex 4	Alexco Keno Hill Mining Corp. - 100%	2006/05/26	2006/06/02	2043/12/31	\$525	5
YC48171		Active	Alex 40	Alexco Keno Hill Mining Corp. - 100%	2006/05/15	2006/06/02	2043/12/31	\$525	5
YC48507		Active	Alex 400	Alexco Keno Hill Mining Corp. - 100%	2006/05/24	2006/06/02	2026/12/31	\$525	5
YC48508		Active	Alex 401	Alexco Keno Hill Mining Corp. - 100%	2006/05/24	2006/06/02	2026/12/31	\$525	5

Grant	Lease	Status	Claim Name	Owner	Staked	Recorded	Expiry	Renewal Cost per Term (CAD)	Term (Years)
YC48509		Active	Alex 403	Alexco Keno Hill Mining Corp. - 100%	2006/05/24	2006/06/02	2026/12/31	\$525	5
YC48510		Active	Alex 404	Alexco Keno Hill Mining Corp. - 100%	2006/05/24	2006/06/02	2026/12/31	\$525	5
YC48172		Active	Alex 41	Alexco Keno Hill Mining Corp. - 100%	2006/05/15	2006/06/02	2043/12/31	\$525	5
YC48173		Active	Alex 42	Alexco Keno Hill Mining Corp. - 100%	2006/05/15	2006/06/02	2043/12/31	\$525	5
YC48511		Active	Alex 423	Alexco Keno Hill Mining Corp. - 100%	2006/05/24	2006/06/02	2026/12/31	\$525	5
YC48512		Active	Alex 424	Alexco Keno Hill Mining Corp. - 100%	2006/05/24	2006/06/02	2026/12/31	\$525	5
YC48513		Active	Alex 425	Alexco Keno Hill Mining Corp. - 100%	2006/05/24	2006/06/02	2026/12/31	\$525	5
YC48514		Active	Alex 429	Alexco Keno Hill Mining Corp. - 100%	2006/05/18	2006/06/02	2043/12/31	\$525	5
YC48174		Active	Alex 43	Alexco Keno Hill Mining Corp. - 100%	2006/05/15	2006/06/02	2043/12/31	\$525	5
YC48515		Active	Alex 430	Alexco Keno Hill Mining Corp. - 100%	2006/05/18	2006/06/02	2043/12/31	\$525	5
YC48516		Active	Alex 431	Alexco Keno Hill Mining Corp. - 100%	2006/05/18	2006/06/02	2043/12/31	\$525	5
YC48517		Active	Alex 432	Alexco Keno Hill Mining Corp. - 100%	2006/05/18	2006/06/02	2043/12/31	\$525	5
YC48518		Active	Alex 433	Alexco Keno Hill Mining Corp. - 100%	2006/05/18	2006/06/02	2043/12/31	\$525	5
YC48519		Active	Alex 434	Alexco Keno Hill Mining Corp. - 100%	2006/05/18	2006/06/02	2043/12/31	\$525	5
YC48520		Active	Alex 435	Alexco Keno Hill Mining Corp. - 100%	2006/05/18	2006/06/02	2043/12/31	\$525	5
YC48521		Active	Alex 436	Alexco Keno Hill Mining Corp. - 100%	2006/05/18	2006/06/02	2043/12/31	\$525	5
YC48522		Active	Alex 437	Alexco Keno Hill Mining Corp. - 100%	2006/05/18	2006/06/02	2043/12/31	\$525	5
YC48523		Active	Alex 438	Alexco Keno Hill Mining Corp. - 100%	2006/05/18	2006/06/02	2043/12/31	\$525	5
YC48524		Active	Alex 439	Alexco Keno Hill Mining Corp. - 100%	2006/05/18	2006/06/02	2043/12/31	\$525	5
YC48175		Active	Alex 44	Alexco Keno Hill Mining Corp. - 100%	2006/05/15	2006/06/02	2043/12/31	\$525	5
YC48525		Active	Alex 440	Alexco Keno Hill Mining Corp. - 100%	2006/05/18	2006/06/02	2043/12/31	\$525	5
YC48526		Active	Alex 441	Alexco Keno Hill Mining Corp. - 100%	2006/05/18	2006/06/02	2043/12/31	\$525	5
YC48527		Active	Alex 442	Alexco Keno Hill Mining Corp. - 100%	2006/05/17	2006/06/02	2043/12/31	\$525	5
YC48528		Active	Alex 443	Alexco Keno Hill Mining Corp. - 100%	2006/05/17	2006/06/02	2043/12/31	\$525	5
YC48529		Active	Alex 444	Alexco Keno Hill Mining Corp. - 100%	2006/05/17	2006/06/02	2043/12/31	\$525	5
YC48530		Active	Alex 445	Alexco Keno Hill Mining Corp. - 100%	2006/05/17	2006/06/02	2043/12/31	\$525	5
YC48531		Active	Alex 446	Alexco Keno Hill Mining Corp. - 100%	2006/05/17	2006/06/02	2043/12/31	\$525	5
YC48532		Active	Alex 447	Alexco Keno Hill Mining Corp. - 100%	2006/05/17	2006/06/02	2043/12/31	\$525	5
YC48533		Active	Alex 448	Alexco Keno Hill Mining Corp. - 100%	2006/05/17	2006/06/02	2043/12/31	\$525	5

Grant	Lease	Status	Claim Name	Owner	Staked	Recorded	Expiry	Renewal Cost per Term (CAD)	Term (Years)
YC48534		Active	Alex 449	Alexco Keno Hill Mining Corp. - 100%	2006/05/17	2006/06/02	2043/12/31	\$525	5
YC48176		Active	Alex 45	Alexco Keno Hill Mining Corp. - 100%	2006/05/21	2006/06/02	2043/12/31	\$525	5
YC48535		Active	Alex 450	Alexco Keno Hill Mining Corp. - 100%	2006/05/17	2006/06/02	2043/12/31	\$525	5
YC48536		Active	Alex 451	Alexco Keno Hill Mining Corp. - 100%	2006/05/17	2006/06/02	2043/12/31	\$525	5
YC48537		Active	Alex 452	Alexco Keno Hill Mining Corp. - 100%	2006/05/17	2006/06/02	2043/12/31	\$525	5
YC48538		Active	Alex 453	Alexco Keno Hill Mining Corp. - 100%	2006/05/17	2006/06/02	2043/12/31	\$525	5
YC48539		Active	Alex 454	Alexco Keno Hill Mining Corp. - 100%	2006/05/16	2006/06/02	2043/12/31	\$525	5
YC48540		Active	Alex 455	Alexco Keno Hill Mining Corp. - 100%	2006/05/16	2006/06/02	2043/12/31	\$525	5
YC48541		Active	Alex 456	Alexco Keno Hill Mining Corp. - 100%	2006/05/16	2006/06/02	2043/12/31	\$525	5
YC48542		Active	Alex 457	Alexco Keno Hill Mining Corp. - 100%	2006/05/16	2006/06/02	2043/12/31	\$525	5
YC48543		Active	Alex 458	Alexco Keno Hill Mining Corp. - 100%	2006/05/16	2006/06/02	2043/12/31	\$525	5
YC48544		Active	Alex 459	Alexco Keno Hill Mining Corp. - 100%	2006/05/16	2006/06/02	2043/12/31	\$525	5
YC48177		Active	Alex 46	Alexco Keno Hill Mining Corp. - 100%	2006/05/21	2006/06/02	2043/12/31	\$525	5
YC48545		Active	Alex 460	Alexco Keno Hill Mining Corp. - 100%	2006/05/18	2006/06/02	2043/12/31	\$525	5
YC48546		Active	Alex 461	Alexco Keno Hill Mining Corp. - 100%	2006/05/18	2006/06/02	2043/12/31	\$525	5
YC48547		Active	Alex 462	Alexco Keno Hill Mining Corp. - 100%	2006/05/18	2006/06/02	2043/12/31	\$525	5
YC56176		Active	Alex 463	Alexco Keno Hill Mining Corp. - 100%	2007/06/12	2007/06/12	2042/12/12	\$525	5
YC56177		Active	Alex 464	Alexco Keno Hill Mining Corp. - 100%	2007/06/12	2007/06/12	2042/12/12	\$525	5
YC56178		Active	Alex 465	Alexco Keno Hill Mining Corp. - 100%	2007/06/12	2007/06/22	2042/12/22	\$525	5
YC56179		Active	Alex 466	Alexco Keno Hill Mining Corp. - 100%	2007/06/12	2007/06/22	2042/12/22	\$525	5
YC56180		Active	Alex 467	Alexco Keno Hill Mining Corp. - 100%	2007/06/09	2007/06/22	2042/12/22	\$525	5
YC56181		Active	Alex 468	Alexco Keno Hill Mining Corp. - 100%	2007/06/12	2007/06/22	2042/12/22	\$525	5
YC56182		Active	Alex 469	Alexco Keno Hill Mining Corp. - 100%	2007/06/09	2007/06/22	2042/12/22	\$525	5
YC48178		Active	Alex 47	Alexco Keno Hill Mining Corp. - 100%	2006/05/21	2006/06/02	2043/12/31	\$525	5
YC56183		Active	Alex 470	Alexco Keno Hill Mining Corp. - 100%	2007/06/12	2007/06/22	2042/12/22	\$525	5
YC56184		Active	Alex 471	Alexco Keno Hill Mining Corp. - 100%	2007/06/09	2007/06/22	2042/12/22	\$525	5
YC56185		Active	Alex 472	Alexco Keno Hill Mining Corp. - 100%	2007/06/12	2007/06/22	2042/12/22	\$525	5
YC56186		Active	Alex 473	Alexco Keno Hill Mining Corp. - 100%	2007/06/09	2007/06/22	2042/12/22	\$525	5
YC56187		Active	Alex 474	Alexco Keno Hill Mining Corp. - 100%	2007/06/12	2007/06/22	2042/12/22	\$525	5

Grant	Lease	Status	Claim Name	Owner	Staked	Recorded	Expiry	Renewal Cost per Term (CAD)	Term (Years)
YC56188		Active	Alex 475	Alexco Keno Hill Mining Corp. - 100%	2007/06/09	2007/06/22	2042/12/22	\$525	5
YC56189		Active	Alex 476	Alexco Keno Hill Mining Corp. - 100%	2007/06/12	2007/06/22	2042/12/22	\$525	5
YC56190		Active	Alex 477	Alexco Keno Hill Mining Corp. - 100%	2007/06/09	2007/06/22	2042/12/22	\$525	5
YC56191		Active	Alex 478	Alexco Keno Hill Mining Corp. - 100%	2007/06/12	2007/06/22	2042/12/22	\$525	5
YC56192		Active	Alex 479	Alexco Keno Hill Mining Corp. - 100%	2007/06/09	2007/06/22	2042/12/22	\$525	5
YC48179		Active	Alex 48	Alexco Keno Hill Mining Corp. - 100%	2006/05/21	2006/06/02	2043/12/31	\$525	5
YC56193		Active	Alex 480	Alexco Keno Hill Mining Corp. - 100%	2007/06/09	2007/06/22	2042/12/22	\$525	5
YC56194		Active	Alex 481	Alexco Keno Hill Mining Corp. - 100%	2007/06/09	2007/06/22	2042/12/22	\$525	5
YC56195		Active	Alex 482	Alexco Keno Hill Mining Corp. - 100%	2007/06/09	2007/06/22	2042/12/22	\$525	5
YC56196		Active	Alex 483	Alexco Keno Hill Mining Corp. - 100%	2007/06/10	2007/06/22	2042/12/22	\$525	5
YC56197		Active	Alex 484	Alexco Keno Hill Mining Corp. - 100%	2007/06/09	2007/06/22	2042/12/22	\$525	5
YC56198		Active	Alex 485	Alexco Keno Hill Mining Corp. - 100%	2007/06/10	2007/06/22	2042/12/22	\$525	5
YC56199		Active	Alex 486	Alexco Keno Hill Mining Corp. - 100%	2007/06/09	2007/06/22	2046/12/22	\$525	5
YC56200		Active	Alex 487	Alexco Keno Hill Mining Corp. - 100%	2007/06/10	2007/06/22	2042/12/22	\$525	5
YC56201		Active	Alex 488	Alexco Keno Hill Mining Corp. - 100%	2007/06/09	2007/06/22	2042/12/22	\$525	5
YC56202		Active	Alex 489	Alexco Keno Hill Mining Corp. - 100%	2007/06/10	2007/06/22	2042/12/22	\$525	5
YC48180		Active	Alex 49	Alexco Keno Hill Mining Corp. - 100%	2006/05/21	2006/06/02	2043/12/31	\$525	5
YC56203		Active	Alex 490	Alexco Keno Hill Mining Corp. - 100%	2007/06/09	2007/06/22	2042/12/22	\$525	5
YC56204		Active	Alex 491	Alexco Keno Hill Mining Corp. - 100%	2007/06/10	2007/06/22	2042/12/22	\$525	5
YC56205		Active	Alex 492	Alexco Keno Hill Mining Corp. - 100%	2007/06/09	2007/06/22	2042/12/22	\$525	5
YC56206		Active	Alex 493	Alexco Keno Hill Mining Corp. - 100%	2007/06/10	2007/06/22	2042/12/22	\$525	5
YC56207		Active	Alex 494	Alexco Keno Hill Mining Corp. - 100%	2007/06/09	2007/06/22	2042/12/22	\$525	5
YC56208		Active	Alex 495	Alexco Keno Hill Mining Corp. - 100%	2007/06/10	2007/06/22	2042/12/22	\$525	5
YC56209		Active	Alex 496	Alexco Keno Hill Mining Corp. - 100%	2007/06/10	2007/06/22	2042/12/22	\$525	5
YC56210		Active	Alex 497	Alexco Keno Hill Mining Corp. - 100%	2007/06/10	2007/06/22	2046/12/22	\$525	5
YC56211		Active	Alex 498	Alexco Keno Hill Mining Corp. - 100%	2007/06/10	2007/06/22	2046/12/22	\$525	5
YC56212		Active	Alex 499	Alexco Keno Hill Mining Corp. - 100%	2007/06/10	2007/06/22	2046/12/22	\$525	5
YC48136		Active	Alex 5	Alexco Keno Hill Mining Corp. - 100%	2006/05/20	2006/06/02	2043/12/31	\$525	5
YC48181		Active	Alex 50	Alexco Keno Hill Mining Corp. - 100%	2006/05/21	2006/06/02	2043/12/31	\$525	5

Grant	Lease	Status	Claim Name	Owner	Staked	Recorded	Expiry	Renewal Cost per Term (CAD)	Term (Years)
YC56213		Active	Alex 500	Alexco Keno Hill Mining Corp. - 100%	2007/06/10	2007/06/22	2046/12/22	\$525	5
YC56214		Active	Alex 501	Alexco Keno Hill Mining Corp. - 100%	2007/06/10	2007/06/22	2046/12/22	\$525	5
YC56215		Active	Alex 502	Alexco Keno Hill Mining Corp. - 100%	2007/06/11	2007/06/22	2042/12/22	\$525	5
YC56216		Active	Alex 503	Alexco Keno Hill Mining Corp. - 100%	2007/06/11	2007/06/22	2046/12/22	\$525	5
YC56217		Active	Alex 504	Alexco Keno Hill Mining Corp. - 100%	2007/06/11	2007/06/22	2042/12/22	\$525	5
YC56218		Active	Alex 505	Alexco Keno Hill Mining Corp. - 100%	2007/06/11	2007/06/22	2042/12/22	\$525	5
YC56219		Active	Alex 506	Alexco Keno Hill Mining Corp. - 100%	2007/06/11	2007/06/22	2042/12/22	\$525	5
YC56220		Active	Alex 507	Alexco Keno Hill Mining Corp. - 100%	2007/06/11	2007/06/22	2042/12/22	\$525	5
YC56221		Active	Alex 508	Alexco Keno Hill Mining Corp. - 100%	2007/06/11	2007/06/22	2042/12/22	\$525	5
YC56222		Active	Alex 509	Alexco Keno Hill Mining Corp. - 100%	2007/06/11	2007/06/22	2042/12/22	\$525	5
YC48182		Active	Alex 51	Alexco Keno Hill Mining Corp. - 100%	2006/05/21	2006/06/02	2043/12/31	\$525	5
YC56223		Active	Alex 510	Alexco Keno Hill Mining Corp. - 100%	2007/06/11	2007/06/22	2042/12/22	\$525	5
YC56224		Active	Alex 511	Alexco Keno Hill Mining Corp. - 100%	2007/06/09	2007/06/22	2042/12/22	\$525	5
YC56225		Active	Alex 512	Alexco Keno Hill Mining Corp. - 100%	2007/06/10	2007/06/22	2042/12/22	\$525	5
YC56226		Active	Alex 513	Alexco Keno Hill Mining Corp. - 100%	2007/06/10	2007/06/22	2042/12/22	\$525	5
YC56227		Active	Alex 514	Alexco Keno Hill Mining Corp. - 100%	2007/06/12	2007/06/22	2042/12/22	\$525	5
YC56228		Active	Alex 515	Alexco Keno Hill Mining Corp. - 100%	2007/06/12	2007/06/22	2042/12/22	\$525	5
YC56229		Active	Alex 516	Alexco Keno Hill Mining Corp. - 100%	2007/06/12	2007/06/22	2042/12/22	\$525	5
YC56230		Active	Alex 517	Alexco Keno Hill Mining Corp. - 100%	2007/06/12	2007/06/22	2042/12/22	\$525	5
YC56231		Active	Alex 518	Alexco Keno Hill Mining Corp. - 100%	2007/06/12	2007/06/22	2042/12/22	\$525	5
YC56232		Active	Alex 519	Alexco Keno Hill Mining Corp. - 100%	2007/06/12	2007/06/22	2042/12/22	\$525	5
YC48183		Active	Alex 52	Alexco Keno Hill Mining Corp. - 100%	2006/05/21	2006/06/02	2043/12/31	\$525	5
YC56233		Active	Alex 520	Alexco Keno Hill Mining Corp. - 100%	2007/06/12	2007/06/22	2042/12/22	\$525	5
YC56234		Active	Alex 521	Alexco Keno Hill Mining Corp. - 100%	2007/06/12	2007/06/22	2042/12/22	\$525	5
YC56235		Active	Alex 522	Alexco Keno Hill Mining Corp. - 100%	2007/06/12	2007/06/22	2042/12/22	\$525	5
YC56236		Active	Alex 523	Alexco Keno Hill Mining Corp. - 100%	2007/06/12	2007/06/22	2042/12/22	\$525	5
YC56237		Active	Alex 524	Alexco Keno Hill Mining Corp. - 100%	2007/06/11	2007/06/22	2042/12/22	\$525	5
YC56238		Active	Alex 525	Alexco Keno Hill Mining Corp. - 100%	2007/06/12	2007/06/22	2042/12/22	\$525	5
YC56239		Active	Alex 526	Alexco Keno Hill Mining Corp. - 100%	2007/06/11	2007/06/22	2042/12/22	\$525	5

Grant	Lease	Status	Claim Name	Owner	Staked	Recorded	Expiry	Renewal Cost per Term (CAD)	Term (Years)
YC56240		Active	Alex 527	Alexco Keno Hill Mining Corp. - 100%	2007/06/11	2007/06/22	2042/12/22	\$525	5
YC56241		Active	Alex 528	Alexco Keno Hill Mining Corp. - 100%	2007/06/11	2007/06/22	2042/12/22	\$525	5
YC56242		Active	Alex 529	Alexco Keno Hill Mining Corp. - 100%	2007/06/11	2007/06/22	2046/12/22	\$525	5
YC48184		Active	Alex 53	Alexco Keno Hill Mining Corp. - 100%	2006/05/20	2006/06/02	2043/12/31	\$525	5
YC56243		Active	Alex 530	Alexco Keno Hill Mining Corp. - 100%	2007/06/11	2007/06/22	2042/12/22	\$525	5
YC56244		Active	Alex 531	Alexco Keno Hill Mining Corp. - 100%	2007/06/11	2007/06/22	2042/12/22	\$525	5
YC56245		Active	Alex 532	Alexco Keno Hill Mining Corp. - 100%	2007/06/11	2007/06/22	2042/12/22	\$525	5
YC56246		Active	Alex 533	Alexco Keno Hill Mining Corp. - 100%	2007/06/11	2007/06/22	2042/12/22	\$525	5
YC56247		Active	Alex 534	Alexco Keno Hill Mining Corp. - 100%	2007/06/11	2007/06/22	2042/12/22	\$525	5
YC56248		Active	Alex 535	Alexco Keno Hill Mining Corp. - 100%	2007/06/11	2007/06/22	2042/12/22	\$525	5
YC56249		Active	Alex 536	Alexco Keno Hill Mining Corp. - 100%	2007/06/11	2007/06/22	2042/12/22	\$525	5
YC56250		Active	Alex 537	Alexco Keno Hill Mining Corp. - 100%	2007/06/11	2007/06/22	2042/12/22	\$525	5
YC56251		Active	Alex 538	Alexco Keno Hill Mining Corp. - 100%	2007/06/11	2007/06/22	2042/12/22	\$525	5
YC56252		Active	Alex 539	Alexco Keno Hill Mining Corp. - 100%	2007/06/11	2007/06/22	2042/12/22	\$525	5
YC48185		Active	Alex 54	Alexco Keno Hill Mining Corp. - 100%	2006/05/20	2006/06/02	2043/12/31	\$525	5
YC56253		Active	Alex 540	Alexco Keno Hill Mining Corp. - 100%	2007/06/11	2007/06/22	2042/12/22	\$525	5
YC56254		Active	Alex 541	Alexco Keno Hill Mining Corp. - 100%	2007/06/11	2007/06/22	2042/12/22	\$525	5
YC56255		Active	Alex 542	Alexco Keno Hill Mining Corp. - 100%	2007/06/11	2007/06/22	2042/12/22	\$525	5
YC56256		Active	Alex 543	Alexco Keno Hill Mining Corp. - 100%	2007/06/11	2007/06/22	2042/12/22	\$525	5
YC56257		Active	Alex 544	Alexco Keno Hill Mining Corp. - 100%	2007/06/11	2007/06/22	2042/12/22	\$525	5
YC56258		Active	Alex 545	Alexco Keno Hill Mining Corp. - 100%	2007/06/11	2007/06/22	2042/12/22	\$525	5
YC56259		Active	Alex 546	Alexco Keno Hill Mining Corp. - 100%	2007/06/11	2007/06/22	2042/12/22	\$525	5
YC56260		Active	Alex 547	Alexco Keno Hill Mining Corp. - 100%	2007/06/11	2007/06/22	2042/12/22	\$525	5
YC56261		Active	Alex 548	Alexco Keno Hill Mining Corp. - 100%	2007/06/11	2007/06/22	2042/12/22	\$525	5
YC56262		Active	Alex 549	Alexco Keno Hill Mining Corp. - 100%	2007/06/11	2007/06/22	2042/12/22	\$525	5
YC48186		Active	Alex 55	Alexco Keno Hill Mining Corp. - 100%	2006/05/20	2006/06/02	2043/12/31	\$525	5
YC56263		Active	Alex 550	Alexco Keno Hill Mining Corp. - 100%	2007/06/11	2007/06/22	2042/12/22	\$525	5
YC56264		Active	Alex 551	Alexco Keno Hill Mining Corp. - 100%	2007/06/11	2007/06/22	2042/12/22	\$525	5
YC56265		Active	Alex 552	Alexco Keno Hill Mining Corp. - 100%	2007/06/12	2007/06/22	2042/12/22	\$525	5

Grant	Lease	Status	Claim Name	Owner	Staked	Recorded	Expiry	Renewal Cost per Term (CAD)	Term (Years)
YC56266		Active	Alex 553	Alexco Keno Hill Mining Corp. - 100%	2007/06/11	2007/06/22	2042/12/22	\$525	5
YC56267		Active	Alex 554	Alexco Keno Hill Mining Corp. - 100%	2007/06/12	2007/06/22	2042/12/22	\$525	5
YC56268		Active	Alex 556	Alexco Keno Hill Mining Corp. - 100%	2007/06/12	2007/06/22	2042/12/22	\$525	5
YC56269		Active	Alex 558	Alexco Keno Hill Mining Corp. - 100%	2007/06/12	2007/06/22	2042/12/22	\$525	5
YC48187		Active	Alex 56	Alexco Keno Hill Mining Corp. - 100%	2006/05/20	2006/06/02	2043/12/31	\$525	5
YC56270		Active	Alex 560	Alexco Keno Hill Mining Corp. - 100%	2007/06/22	2007/06/22	2042/12/22	\$525	5
YC56271		Active	Alex 562	Alexco Keno Hill Mining Corp. - 100%	2007/06/12	2007/06/22	2042/12/22	\$525	5
YC56272		Active	Alex 564	Alexco Keno Hill Mining Corp. - 100%	2007/06/10	2007/06/22	2042/12/22	\$525	5
YC56273		Active	Alex 565	Alexco Keno Hill Mining Corp. - 100%	2007/06/10	2007/06/13	2042/12/13	\$525	5
YC48188		Active	Alex 57	Alexco Keno Hill Mining Corp. - 100%	2006/05/20	2006/06/02	2043/12/31	\$525	5
YC48189		Active	Alex 58	Alexco Keno Hill Mining Corp. - 100%	2006/05/20	2006/06/02	2043/12/31	\$525	5
YC48190		Active	Alex 59	Alexco Keno Hill Mining Corp. - 100%	2006/05/20	2006/06/02	2043/12/31	\$525	5
YC48137		Active	Alex 6	Alexco Keno Hill Mining Corp. - 100%	2006/05/20	2006/06/02	2043/12/31	\$525	5
YC48191		Active	Alex 60	Alexco Keno Hill Mining Corp. - 100%	2006/05/20	2006/06/02	2043/12/31	\$525	5
YC56874		Active	Alex 601	Alexco Keno Hill Mining Corp. - 100%	2007/07/14	2007/07/24	2026/12/31	\$525	5
YC56875		Active	Alex 602	Alexco Keno Hill Mining Corp. - 100%	2007/07/14	2007/07/24	2026/12/31	\$525	5
YC56876		Active	Alex 603	Alexco Keno Hill Mining Corp. - 100%	2007/07/14	2007/07/24	2026/12/31	\$525	5
YC56877		Active	Alex 604	Alexco Keno Hill Mining Corp. - 100%	2007/07/14	2007/07/24	2026/12/31	\$525	5
YC56878		Active	Alex 605	Alexco Keno Hill Mining Corp. - 100%	2007/07/14	2007/07/24	2026/12/31	\$525	5
YC56879		Active	Alex 606	Alexco Keno Hill Mining Corp. - 100%	2007/07/14	2007/07/24	2026/12/31	\$525	5
YC48192		Active	Alex 61	Alexco Keno Hill Mining Corp. - 100%	2006/05/20	2006/06/02	2043/12/31	\$525	5
YC48193		Active	Alex 62	Alexco Keno Hill Mining Corp. - 100%	2006/05/20	2006/06/02	2043/12/31	\$525	5
YC48194		Active	Alex 63	Alexco Keno Hill Mining Corp. - 100%	2006/05/20	2006/06/02	2043/12/31	\$525	5
YC48195		Active	Alex 64	Alexco Keno Hill Mining Corp. - 100%	2006/05/20	2006/06/02	2043/12/31	\$525	5
YC48196		Active	Alex 65	Alexco Keno Hill Mining Corp. - 100%	2006/05/20	2006/06/02	2043/12/31	\$525	5
YC48197		Active	Alex 66	Alexco Keno Hill Mining Corp. - 100%	2006/05/20	2006/06/02	2043/12/31	\$525	5
YC48198		Active	Alex 67	Alexco Keno Hill Mining Corp. - 100%	2006/05/20	2006/06/02	2043/12/31	\$525	5
YC48199		Active	Alex 68	Alexco Keno Hill Mining Corp. - 100%	2006/05/20	2006/06/02	2043/12/31	\$525	5
YC48200		Active	Alex 69	Alexco Keno Hill Mining Corp. - 100%	2006/05/20	2006/06/02	2043/12/31	\$525	5

Grant	Lease	Status	Claim Name	Owner	Staked	Recorded	Expiry	Renewal Cost per Term (CAD)	Term (Years)
YC48138		Active	Alex 7	Alexco Keno Hill Mining Corp. - 100%	2006/05/20	2006/06/02	2043/12/31	\$525	5
YC48201		Active	Alex 70	Alexco Keno Hill Mining Corp. - 100%	2006/05/20	2006/06/02	2043/12/31	\$525	5
YC48202		Active	Alex 71	Alexco Keno Hill Mining Corp. - 100%	2006/05/20	2006/06/02	2043/12/31	\$525	5
YC48203		Active	Alex 72	Alexco Keno Hill Mining Corp. - 100%	2006/05/20	2006/06/02	2043/12/31	\$525	5
YC48204		Active	Alex 73	Alexco Keno Hill Mining Corp. - 100%	2006/05/20	2006/06/02	2043/12/31	\$525	5
YC48205		Active	Alex 74	Alexco Keno Hill Mining Corp. - 100%	2006/05/20	2006/06/02	2043/12/31	\$525	5
YC48206		Active	Alex 75	Alexco Keno Hill Mining Corp. - 100%	2006/05/20	2006/06/02	2043/12/31	\$525	5
YC48207		Active	Alex 76	Alexco Keno Hill Mining Corp. - 100%	2006/05/20	2006/06/02	2043/12/31	\$525	5
YC48208		Active	Alex 77	Alexco Keno Hill Mining Corp. - 100%	2006/05/22	2006/05/22	2043/12/31	\$525	5
YC48209		Active	Alex 78	Alexco Keno Hill Mining Corp. - 100%	2006/05/22	2006/05/22	2043/12/31	\$525	5
YC48210		Active	Alex 79	Alexco Keno Hill Mining Corp. - 100%	2006/05/22	2006/05/22	2043/12/31	\$525	5
YC48139		Active	Alex 8	Alexco Keno Hill Mining Corp. - 100%	2006/05/20	2006/06/02	2043/12/31	\$525	5
YC48211		Active	Alex 80	Alexco Keno Hill Mining Corp. - 100%	2006/05/22	2006/05/22	2043/12/31	\$525	5
YC48212		Active	Alex 81	Alexco Keno Hill Mining Corp. - 100%	2006/05/22	2006/05/22	2043/12/31	\$525	5
YC48213		Active	Alex 82	Alexco Keno Hill Mining Corp. - 100%	2006/05/22	2006/05/22	2043/12/31	\$525	5
YC48214		Active	Alex 83	Alexco Keno Hill Mining Corp. - 100%	2006/05/22	2006/05/22	2043/12/31	\$525	5
YC48215		Active	Alex 84	Alexco Keno Hill Mining Corp. - 100%	2006/05/22	2006/05/22	2043/12/31	\$525	5
YC48216		Active	Alex 85	Alexco Keno Hill Mining Corp. - 100%	2006/05/22	2006/05/22	2043/12/31	\$525	5
YC48217		Active	Alex 86	Alexco Keno Hill Mining Corp. - 100%	2006/05/22	2006/05/22	2043/12/31	\$525	5
YC48218		Active	Alex 87	Alexco Keno Hill Mining Corp. - 100%	2006/05/22	2006/05/22	2043/12/31	\$525	5
YC48219		Active	Alex 88	Alexco Keno Hill Mining Corp. - 100%	2006/05/22	2006/05/22	2043/12/31	\$525	5
YC48220		Active	Alex 89	Alexco Keno Hill Mining Corp. - 100%	2006/05/22	2006/05/22	2043/12/31	\$525	5
YC48140		Active	Alex 9	Alexco Keno Hill Mining Corp. - 100%	2006/05/20	2006/06/02	2043/12/31	\$525	5
YC48221		Active	Alex 90	Alexco Keno Hill Mining Corp. - 100%	2006/05/22	2006/05/22	2043/12/31	\$525	5
YC48222		Active	Alex 91	Alexco Keno Hill Mining Corp. - 100%	2006/05/22	2006/05/22	2043/12/31	\$525	5
YC48223		Active	Alex 92	Alexco Keno Hill Mining Corp. - 100%	2006/05/22	2006/05/22	2043/12/31	\$525	5
YC48224		Active	Alex 93	Alexco Keno Hill Mining Corp. - 100%	2006/05/22	2006/05/22	2043/12/31	\$525	5
YC48225		Active	Alex 94	Alexco Keno Hill Mining Corp. - 100%	2006/05/22	2006/05/22	2043/12/31	\$525	5
YC48226		Active	Alex 95	Alexco Keno Hill Mining Corp. - 100%	2006/05/22	2006/05/22	2043/12/31	\$525	5

Grant	Lease	Status	Claim Name	Owner	Staked	Recorded	Expiry	Renewal Cost per Term (CAD)	Term (Years)
YC48227		Active	Alex 96	Alexco Keno Hill Mining Corp. - 100%	2006/05/22	2006/05/22	2043/12/31	\$525	5
YC48228		Active	Alex 97	Alexco Keno Hill Mining Corp. - 100%	2006/05/22	2006/05/22	2043/12/31	\$525	5
YC48229		Active	Alex 98	Alexco Keno Hill Mining Corp. - 100%	2006/05/22	2006/05/22	2043/12/31	\$525	5
YC48230		Active	Alex 99	Alexco Keno Hill Mining Corp. - 100%	2006/05/22	2006/05/22	2043/12/31	\$525	5
55429	NM00533	Active	BALTO	Alexco Keno Hill Mining Corp. - 100%	1946/05/25	1946/06/06	2027/11/02	\$210	21
YC01993	NM00720	Active	Blue	Alexco Keno Hill Mining Corp. - 100%	1999/09/09	1999/09/10	2033/10/02	\$210	21
YC90545	NM00721	Active	Blue Fr. 2	Alexco Keno Hill Mining Corp. - 100%	2011/09/17	2011/09/20	2033/10/02	\$210	21
YC90546	NM00722	Active	Blue Fr. 3	Alexco Keno Hill Mining Corp. - 100%	2011/09/17	2011/09/20	2033/10/02	\$210	21
YC90503	NM00719	Active	BULLDOZER F 2	Alexco Keno Hill Mining Corp. - 100%	2012/08/26	2012/08/27	2033/10/02	\$210	21
59534	NM00543	Active	BUNKER	Alexco Keno Hill Mining Corp. - 100%	1950/03/18	1950/04/01	2027/11/02	\$210	21
59535	NM00544	Active	BUNKER NO. 1	Alexco Keno Hill Mining Corp. - 100%	1950/03/18	1950/04/01	2027/11/02	\$210	21
55587	NM00294	Active	CAIN	Alexco Keno Hill Mining Corp. - 100%	1946/10/08	1947/03/28	2025/02/23	\$210	21
81152		Active	Carol	Alexco Keno Hill Mining Corp. - 100%	1962/05/29	1962/06/04	2043/12/31	\$525	5
80239		Active	Carol 1	Alexco Keno Hill Mining Corp. - 100%	1957/10/08	1957/10/16	2043/12/31	\$525	5
80240		Active	Carol 2	Alexco Keno Hill Mining Corp. - 100%	1957/10/08	1957/10/16	2043/12/31	\$525	5
80241		Active	Carol 3	Alexco Keno Hill Mining Corp. - 100%	1957/10/08	1957/10/16	2043/12/31	\$525	5
80242		Active	Carol 4	Alexco Keno Hill Mining Corp. - 100%	1957/10/08	1957/10/16	2043/12/31	\$525	5
80348		Active	Carol 5	Alexco Keno Hill Mining Corp. - 100%	1959/06/26	1959/07/02	2043/12/31	\$525	5
YC02670		Active	Chiko 1	Alexco Keno Hill Mining Corp. - 100%	2000/10/12	2000/10/27	2038/12/31	\$525	5
YC02679		Active	Chiko 10	Alexco Keno Hill Mining Corp. - 100%	2000/10/14	2000/10/27	2037/12/31	\$525	5
YC02671		Active	Chiko 2	Alexco Keno Hill Mining Corp. - 100%	2000/10/12	2000/10/27	2037/12/31	\$525	5
YC02672		Active	Chiko 3	Alexco Keno Hill Mining Corp. - 100%	2000/10/12	2000/10/27	2037/12/31	\$525	5
YC02673		Active	Chiko 4	Alexco Keno Hill Mining Corp. - 100%	2000/10/12	2000/10/27	2037/12/31	\$525	5
YC02674		Active	Chiko 5	Alexco Keno Hill Mining Corp. - 100%	2000/10/12	2000/10/27	2037/12/31	\$525	5
YC02675		Active	Chiko 6	Alexco Keno Hill Mining Corp. - 100%	2000/10/12	2000/10/27	2037/12/31	\$525	5
YC02676		Active	Chiko 7	Alexco Keno Hill Mining Corp. - 100%	2000/10/14	2000/10/27	2037/12/31	\$525	5
YC02677		Active	Chiko 8	Alexco Keno Hill Mining Corp. - 100%	2000/10/14	2000/10/27	2037/12/31	\$525	5
YC02678		Active	Chiko Fr. 9	Alexco Keno Hill Mining Corp. - 100%	2000/10/14	2000/10/27	2037/12/31	\$525	5
59645	NM00545	Active	DAISY FRACTION	Alexco Keno Hill Mining Corp. - 100%	1950/07/15	1950/07/22	2027/11/02	\$210	21

Grant	Lease	Status	Claim Name	Owner	Staked	Recorded	Expiry	Renewal Cost per Term (CAD)	Term (Years)
16097	NM00531	Active	DAVID	Alexco Keno Hill Mining Corp. - 100%	1925/11/14	1925/12/08	2027/11/02	\$210	21
YC57134		Active	Doh Fr.	Alexco Keno Hill Mining Corp. - 100%	2007/08/04	2007/08/21	2028/12/31	\$525	5
61599	NM00550	Active	DON FRACTION	Alexco Keno Hill Mining Corp. - 100%	1951/05/23	1951/05/25	2027/11/02	\$210	21
59692	NM00200	Active	DORA	Alexco Keno Hill Mining Corp. - 100%	1950/09/11	1950/09/19	2028/07/29	\$210	21
59932	NM00548	Active	DUDE	Alexco Keno Hill Mining Corp. - 100%	1950/10/05	1950/10/11	2027/11/02	\$210	21
YC90504		Pending	Duncan Fr. 4	Alexco Keno Hill Mining Corp. - 100%	2013/09/13	2013/09/13	2036/09/13	\$525	5
59519	NM00542	Active	EVY	Alexco Keno Hill Mining Corp. - 100%	1949/11/24	1949/11/30	2027/11/02	\$210	21
61916	NM00554	Active	EVY	Alexco Keno Hill Mining Corp. - 100%	1951/08/16	1951/08/29	2027/11/02	\$210	21
55592	NM00539	Active	FOX	Alexco Keno Hill Mining Corp. - 100%	1946/10/12	1947/03/28	2027/11/02	\$210	21
61877	NM00553	Active	FOX	Alexco Keno Hill Mining Corp. - 100%	1951/08/13	1951/08/15	2027/11/02	\$210	21
55593	NM00540	Active	GRETA	Alexco Keno Hill Mining Corp. - 100%	1946/10/16	1947/03/28	2027/11/02	\$210	21
61600	NM00551	Active	GROUSE	Alexco Keno Hill Mining Corp. - 100%	1951/05/13	1951/05/25	2027/11/02	\$210	21
YC02323		Active	Hoito 1	Alexco Keno Hill Mining Corp. - 100%	1999/12/11	1999/12/29	2046/12/29	\$525	5
YC02324		Active	Hoito 2	Alexco Keno Hill Mining Corp. - 100%	1999/12/11	1999/12/29	2046/12/29	\$525	5
YC02326		Active	Hoito 4	Alexco Keno Hill Mining Corp. - 100%	1999/12/12	1999/12/29	2046/12/29	\$525	5
YC02328		Active	Hoito 6	Alexco Keno Hill Mining Corp. - 100%	1999/12/12	1999/12/29	2046/12/29	\$525	5
YC02330		Active	Hoito 8	Alexco Keno Hill Mining Corp. - 100%	1999/12/12	1999/12/29	2046/12/29	\$525	5
55589	NM00296	Active	HORSESHOE	Alexco Keno Hill Mining Corp. - 100%	1946/10/08	1947/03/28	2025/02/23	\$210	21
61598	NM00549	Active	JIB NO. 2	Alexco Keno Hill Mining Corp. - 100%	1951/05/16	1951/05/25	2027/11/02	\$210	21
84489		Active	Joe 2	Alexco Keno Hill Mining Corp. - 100%	1965/05/28	1965/06/02	2043/12/31	\$525	5
80453		Active	Joe No. 1	Alexco Keno Hill Mining Corp. - 100%	1960/07/18	1960/05/27	2043/12/31	\$525	5
YC42549		Active	K 1	Alexco Keno Hill Mining Corp. - 100%	2005/12/04	2005/12/15	2047/12/15	\$525	5
YC42558		Active	K 10	Alexco Keno Hill Mining Corp. - 100%	2005/11/30	2005/12/15	2043/12/15	\$525	5
YC56127		Active	K 100	Alexco Keno Hill Mining Corp. - 100%	2007/06/15	2007/06/15	2024/12/31	\$525	5
YC56128		Active	K 101	Alexco Keno Hill Mining Corp. - 100%	2007/06/15	2007/06/15	2024/12/31	\$525	5
YC56129		Active	K 102	Alexco Keno Hill Mining Corp. - 100%	2007/06/15	2007/06/15	2024/12/31	\$525	5
YC56155		Active	K 103	Alexco Keno Hill Mining Corp. - 100%	2007/06/21	2007/06/22	2027/12/31	\$525	5
YC56156		Active	K 104	Alexco Keno Hill Mining Corp. - 100%	2007/06/21	2007/06/22	2027/12/31	\$525	5
YC56157		Active	K 105	Alexco Keno Hill Mining Corp. - 100%	2007/06/21	2007/06/22	2027/12/31	\$525	5

Grant	Lease	Status	Claim Name	Owner	Staked	Recorded	Expiry	Renewal Cost per Term (CAD)	Term (Years)
YC56158		Active	K 106	Alexco Keno Hill Mining Corp. - 100%	2007/06/21	2007/06/22	2027/12/31	\$525	5
YC56159		Active	K 107	Alexco Keno Hill Mining Corp. - 100%	2007/06/21	2007/06/22	2027/12/31	\$525	5
YC42559		Active	K 11	Alexco Keno Hill Mining Corp. - 100%	2005/11/30	2005/12/15	2043/12/15	\$525	5
YC42560		Active	K 12	Alexco Keno Hill Mining Corp. - 100%	2005/11/30	2005/12/15	2043/12/15	\$525	5
YC42561		Active	K 13	Alexco Keno Hill Mining Corp. - 100%	2005/11/30	2005/12/15	2043/12/15	\$525	5
YC42562		Active	K 14	Alexco Keno Hill Mining Corp. - 100%	2005/11/30	2005/12/15	2043/12/15	\$525	5
YC42563		Active	K 15	Alexco Keno Hill Mining Corp. - 100%	2005/11/30	2005/12/15	2043/12/15	\$525	5
YC42564		Active	K 16	Alexco Keno Hill Mining Corp. - 100%	2005/11/30	2005/12/15	2043/12/15	\$525	5
YC42565		Active	K 17	Alexco Keno Hill Mining Corp. - 100%	2005/11/30	2005/12/15	2043/12/15	\$525	5
YC42566		Active	K 18	Alexco Keno Hill Mining Corp. - 100%	2005/11/30	2005/12/15	2043/12/15	\$525	5
YC42567		Active	K 19	Alexco Keno Hill Mining Corp. - 100%	2005/11/30	2005/12/15	2043/12/15	\$525	5
YC42550		Active	K 2	Alexco Keno Hill Mining Corp. - 100%	2005/12/04	2005/12/15	2047/12/15	\$525	5
YC42568		Active	K 20	Alexco Keno Hill Mining Corp. - 100%	2005/11/29	2005/12/15	2043/12/15	\$525	5
YC42569		Active	K 21	Alexco Keno Hill Mining Corp. - 100%	2005/11/30	2005/12/15	2043/12/15	\$525	5
YC42570		Active	K 22	Alexco Keno Hill Mining Corp. - 100%	2005/11/30	2005/12/15	2043/12/15	\$525	5
YC42571		Active	K 23	Alexco Keno Hill Mining Corp. - 100%	2005/11/30	2005/12/15	2043/12/15	\$525	5
YC42572		Active	K 24	Alexco Keno Hill Mining Corp. - 100%	2005/11/30	2005/12/15	2043/12/15	\$525	5
YC42573		Active	K 25	Alexco Keno Hill Mining Corp. - 100%	2005/11/30	2005/12/15	2043/12/15	\$525	5
YC42574		Active	K 26	Alexco Keno Hill Mining Corp. - 100%	2005/11/30	2005/12/15	2043/12/15	\$525	5
YC42575		Active	K 27	Alexco Keno Hill Mining Corp. - 100%	2005/12/03	2005/12/15	2030/12/15	\$525	5
YC42576	NM00715	Active	K 28	Alexco Keno Hill Mining Corp. - 100%	2005/12/03	2005/12/15	2033/10/02	\$210	21
YC42577		Active	K 29	Alexco Keno Hill Mining Corp. - 100%	2005/12/03	2005/12/15	2030/12/15	\$525	5
YC42551		Active	K 3	Alexco Keno Hill Mining Corp. - 100%	2005/12/04	2005/12/15	2047/12/15	\$525	5
YC42578	NM00716	Active	K 30	Alexco Keno Hill Mining Corp. - 100%	2005/12/03	2005/12/15	2033/10/02	\$210	21
YC42579		Active	K 31	Alexco Keno Hill Mining Corp. - 100%	2005/12/03	2005/12/15	2030/12/15	\$525	5
YC42580	NM00717	Active	K 32	Alexco Keno Hill Mining Corp. - 100%	2005/12/03	2005/12/15	2033/10/02	\$210	21
YC42581		Active	K 33	Alexco Keno Hill Mining Corp. - 100%	2005/12/01	2005/12/15	2043/12/15	\$525	5
YC42582		Active	K 34	Alexco Keno Hill Mining Corp. - 100%	2005/12/01	2005/12/15	2043/12/15	\$525	5
YC42583		Active	K 35	Alexco Keno Hill Mining Corp. - 100%	2005/12/01	2005/12/01	2047/12/31	\$525	5

Grant	Lease	Status	Claim Name	Owner	Staked	Recorded	Expiry	Renewal Cost per Term (CAD)	Term (Years)
YC42584		Active	K 36	Alexco Keno Hill Mining Corp. - 100%	2005/12/01	2005/12/01	2043/12/31	\$525	5
YC42585		Active	K 37	Alexco Keno Hill Mining Corp. - 100%	2005/12/01	2005/12/01	2043/12/31	\$525	5
YC42586		Active	K 38	Alexco Keno Hill Mining Corp. - 100%	2005/12/01	2005/12/01	2043/12/31	\$525	5
YC42587		Active	K 39	Alexco Keno Hill Mining Corp. - 100%	2005/12/01	2005/12/15	2043/12/15	\$525	5
YC42552		Active	K 4	Alexco Keno Hill Mining Corp. - 100%	2005/12/04	2005/12/15	2043/12/15	\$525	5
YC42588		Active	K 40	Alexco Keno Hill Mining Corp. - 100%	2005/12/01	2005/12/15	2043/12/15	\$525	5
YC42589		Active	K 41	Alexco Keno Hill Mining Corp. - 100%	2005/12/03	2005/12/15	2037/12/15	\$525	5
YC42590		Active	K 42	Alexco Keno Hill Mining Corp. - 100%	2005/12/03	2005/12/15	2037/12/15	\$525	5
YC42591		Active	K 43	Alexco Keno Hill Mining Corp. - 100%	2005/12/04	2005/12/15	2037/12/15	\$525	5
YC42592		Active	K 44	Alexco Keno Hill Mining Corp. - 100%	2005/12/04	2005/12/15	2037/12/15	\$525	5
YC42593		Active	K 45	Alexco Keno Hill Mining Corp. - 100%	2005/12/04	2005/12/15	2037/12/15	\$525	5
YC42594		Active	K 46	Alexco Keno Hill Mining Corp. - 100%	2005/12/04	2005/12/15	2040/12/15	\$525	5
YC42595		Active	K 47	Alexco Keno Hill Mining Corp. - 100%	2005/12/04	2005/12/15	2037/12/15	\$525	5
YC42596		Active	K 48	Alexco Keno Hill Mining Corp. - 100%	2005/12/04	2005/12/15	2037/12/15	\$525	5
YC42597		Active	K 49	Alexco Keno Hill Mining Corp. - 100%	2005/12/03	2005/12/03	2038/12/31	\$525	5
YC42553		Active	K 5	Alexco Keno Hill Mining Corp. - 100%	2005/12/04	2005/12/15	2043/12/15	\$525	5
YC42598		Active	K 50	Alexco Keno Hill Mining Corp. - 100%	2005/12/03	2005/12/15	2037/12/15	\$525	5
YC42599		Active	K 51	Alexco Keno Hill Mining Corp. - 100%	2005/12/03	2005/12/15	2037/12/31	\$525	5
YC42600		Active	K 52	Alexco Keno Hill Mining Corp. - 100%	2005/12/03	2005/12/03	2037/12/03	\$525	5
YC42601		Active	K 53	Alexco Keno Hill Mining Corp. - 100%	2005/12/05	2005/12/05	2027/12/31	\$525	5
YC42602		Active	K 54	Alexco Keno Hill Mining Corp. - 100%	2005/12/05	2005/12/15	2027/12/15	\$525	5
YC42605		Active	K 57	Alexco Keno Hill Mining Corp. - 100%	2005/12/05	2005/12/15	2038/12/15	\$525	5
YC42606		Active	K 58	Alexco Keno Hill Mining Corp. - 100%	2005/12/05	2005/12/15	2037/12/15	\$525	5
YC42607		Active	K 59	Alexco Keno Hill Mining Corp. - 100%	2005/12/05	2005/12/15	2037/12/15	\$525	5
YC42554		Active	K 6	Alexco Keno Hill Mining Corp. - 100%	2005/12/04	2005/12/15	2043/12/15	\$525	5
YC42608		Active	K 60	Alexco Keno Hill Mining Corp. - 100%	2005/12/05	2005/12/15	2038/12/15	\$525	5
YC42609		Active	K 61	Alexco Keno Hill Mining Corp. - 100%	2005/12/05	2005/12/15	2043/12/15	\$525	5
YC42610		Active	K 62	Alexco Keno Hill Mining Corp. - 100%	2005/12/05	2005/12/15	2043/12/15	\$525	5
YC42611		Active	K 63	Alexco Keno Hill Mining Corp. - 100%	2005/12/01	2005/12/15	2043/12/15	\$525	5

Grant	Lease	Status	Claim Name	Owner	Staked	Recorded	Expiry	Renewal Cost per Term (CAD)	Term (Years)
YC42612		Active	K 64	Alexco Keno Hill Mining Corp. - 100%	2005/12/01	2005/12/15	2043/12/15	\$525	5
YC42613		Active	K 65	Alexco Keno Hill Mining Corp. - 100%	2005/12/01	2005/12/15	2043/12/15	\$525	5
YC42614		Active	K 66	Alexco Keno Hill Mining Corp. - 100%	2005/12/01	2005/12/15	2043/12/15	\$525	5
YC42615		Active	K 67	Alexco Keno Hill Mining Corp. - 100%	2005/12/01	2005/12/15	2043/12/15	\$525	5
YC42616		Active	K 68	Alexco Keno Hill Mining Corp. - 100%	2005/12/01	2005/12/15	2043/12/15	\$525	5
YC42617		Active	K 69	Alexco Keno Hill Mining Corp. - 100%	2005/12/02	2005/12/15	2047/12/15	\$525	5
YC42555		Active	K 7	Alexco Keno Hill Mining Corp. - 100%	2005/11/30	2005/12/15	2043/12/15	\$525	5
YC42618		Active	K 70	Alexco Keno Hill Mining Corp. - 100%	2005/12/02	2005/12/15	2047/12/15	\$525	5
YC42619		Active	K 71	Alexco Keno Hill Mining Corp. - 100%	2005/12/02	2005/12/15	2043/12/15	\$525	5
YC42620		Active	K 72	Alexco Keno Hill Mining Corp. - 100%	2005/12/02	2005/12/15	2043/12/15	\$525	5
YC42621		Active	K 73	Alexco Keno Hill Mining Corp. - 100%	2005/12/02	2005/12/15	2043/12/15	\$525	5
YC42622		Active	K 74	Alexco Keno Hill Mining Corp. - 100%	2005/12/02	2005/12/15	2043/12/15	\$525	5
YC42623		Active	K 75	Alexco Keno Hill Mining Corp. - 100%	2005/12/02	2005/12/15	2043/12/15	\$525	5
YC42624		Active	K 76	Alexco Keno Hill Mining Corp. - 100%	2005/12/02	2005/12/15	2043/12/15	\$525	5
YC42625		Active	k 77	Alexco Keno Hill Mining Corp. - 100%	2005/12/05	2005/12/15	2039/12/15	\$525	5
YC42626		Active	k 78	Alexco Keno Hill Mining Corp. - 100%	2005/12/05	2005/12/15	2043/12/15	\$525	5
YC42627		Active	K 79	Alexco Keno Hill Mining Corp. - 100%	2005/12/02	2005/12/15	2027/12/15	\$525	5
YC42556		Active	K 8	Alexco Keno Hill Mining Corp. - 100%	2005/11/30	2005/12/15	2043/12/15	\$525	5
YC42628	NM00718	Active	K 80	Alexco Keno Hill Mining Corp. - 100%	2005/12/05	2005/12/15	2033/10/02	\$210	21
YC42629		Active	K 81	Alexco Keno Hill Mining Corp. - 100%	2005/12/02	2005/12/15	2027/12/15	\$525	5
YC42630		Active	K 82	Alexco Keno Hill Mining Corp. - 100%	2005/12/02	2005/12/15	2027/12/15	\$525	5
YC42631		Active	K 83	Alexco Keno Hill Mining Corp. - 100%	2005/12/02	2005/12/15	2027/12/15	\$525	5
YC42632		Active	K 84	Alexco Keno Hill Mining Corp. - 100%	2005/12/02	2005/12/15	2027/12/15	\$525	5
YC42633		Active	K 85	Alexco Keno Hill Mining Corp. - 100%	2005/12/05	2005/12/15	2033/12/15	\$525	5
YC55953		Active	K 87	Alexco Keno Hill Mining Corp. - 100%	2007/05/26	2007/05/28	2043/12/31	\$525	5
YC56115		Active	K 88	Alexco Keno Hill Mining Corp. - 100%	2007/06/13	2007/06/13	2027/12/31	\$525	5
YC56116		Active	K 89	Alexco Keno Hill Mining Corp. - 100%	2007/06/12	2007/06/13	2043/12/31	\$525	5
YC42557		Active	K 9	Alexco Keno Hill Mining Corp. - 100%	2005/11/30	2005/12/15	2043/12/15	\$525	5
YC56117		Active	K 90	Alexco Keno Hill Mining Corp. - 100%	2007/06/12	2007/06/13	2042/12/31	\$525	5

Grant	Lease	Status	Claim Name	Owner	Staked	Recorded	Expiry	Renewal Cost per Term (CAD)	Term (Years)
YC56118		Active	K 91	Alexco Keno Hill Mining Corp. - 100%	2007/06/11	2007/06/13	2028/12/31	\$525	5
YC56119		Active	K 92	Alexco Keno Hill Mining Corp. - 100%	2007/06/11	2007/06/13	2028/12/31	\$525	5
YC56120		Active	K 93	Alexco Keno Hill Mining Corp. - 100%	2007/06/13	2007/06/13	2028/12/31	\$525	5
YC56121		Active	K 94	Alexco Keno Hill Mining Corp. - 100%	2007/06/13	2007/06/13	2028/12/31	\$525	5
YC56122		Active	K 95	Alexco Keno Hill Mining Corp. - 100%	2007/06/14	2007/06/15	2028/12/31	\$525	5
YC56123		Active	K 96	Alexco Keno Hill Mining Corp. - 100%	2007/06/14	2007/06/15	2028/12/31	\$525	5
YC56124		Active	K 97	Alexco Keno Hill Mining Corp. - 100%	2007/06/14	2007/06/15	2028/12/15	\$525	5
YC56125		Active	K 98	Alexco Keno Hill Mining Corp. - 100%	2007/06/14	2007/06/15	2028/12/15	\$525	5
YC56126		Active	K 99	Alexco Keno Hill Mining Corp. - 100%	2007/06/14	2007/06/15	2028/12/15	\$525	5
YC90502		Active	K Fr. 109	Alexco Keno Hill Mining Corp. - 100%	2012/08/19	2012/09/10	2028/09/10	\$525	5
YC90501		Active	K Fr. 110	Alexco Keno Hill Mining Corp. - 100%	2012/08/19	2012/09/10	2028/09/10	\$525	5
YC69940	NM00641	Active	K108F	Alexco Keno Hill Mining Corp. - 100%	2008/09/02	2008/09/10	2030/02/23	\$210	21
YB64184		Active	Lakehead 1	Alexco Keno Hill Mining Corp. - 100%	1995/06/27	1995/06/28	2038/12/31	\$525	5
YB64185		Active	Lakehead 2	Alexco Keno Hill Mining Corp. - 100%	1995/06/27	1995/06/28	2038/12/31	\$525	5
YA17395	NM00638	Active	Lem 1	Alexco Keno Hill Mining Corp. - 100%	1977/11/04	1977/11/14	2030/02/23	\$210	21
YA17404		Active	Lem 10	Alexco Keno Hill Mining Corp. - 100%	1977/11/10	1977/11/14	2026/12/31	\$525	5
YA17405		Active	Lem 11	Alexco Keno Hill Mining Corp. - 100%	1977/11/10	1977/11/14	2026/12/31	\$525	5
YA17396	NM00639	Active	Lem 2	Alexco Keno Hill Mining Corp. - 100%	1977/11/04	1977/11/14	2030/02/23	\$210	21
YA17397	NM00640	Active	Lem 3	Alexco Keno Hill Mining Corp. - 100%	1977/11/04	1977/11/14	2030/02/23	\$210	21
YA17398		Active	Lem 4	Alexco Keno Hill Mining Corp. - 100%	1977/11/04	1977/11/14	2026/12/31	\$525	5
YA17399		Active	Lem 5	Alexco Keno Hill Mining Corp. - 100%	1977/11/10	1977/11/14	2026/12/31	\$525	5
YA17400		Active	Lem 6	Alexco Keno Hill Mining Corp. - 100%	1977/11/10	1977/11/14	2026/12/31	\$525	5
YA17401		Active	Lem 7	Alexco Keno Hill Mining Corp. - 100%	1977/11/10	1977/11/14	2026/12/31	\$525	5
YA17402		Active	Lem 8	Alexco Keno Hill Mining Corp. - 100%	1977/11/10	1977/11/14	2026/12/31	\$525	5
YA17403		Active	Lem 9	Alexco Keno Hill Mining Corp. - 100%	1977/11/10	1977/11/14	2026/12/31	\$525	5
YD63291		Active	LJ 1	Alexco Keno Hill Mining Corp. - 100%	2010/12/20	2010/12/22	2043/12/22	\$525	5
YD63300		Active	LJ 10	Alexco Keno Hill Mining Corp. - 100%	2010/12/20	2010/12/22	2043/12/22	\$525	5
YC90548		Active	LJ 11	Alexco Keno Hill Mining Corp. - 100%	2011/08/31	2011/09/02	2043/12/31	\$525	5
YD63292		Active	LJ 2	Alexco Keno Hill Mining Corp. - 100%	2010/12/20	2010/12/22	2043/12/22	\$525	5

Grant	Lease	Status	Claim Name	Owner	Staked	Recorded	Expiry	Renewal Cost per Term (CAD)	Term (Years)
YD63293		Active	LJ 3	Alexco Keno Hill Mining Corp. - 100%	2010/12/20	2010/12/22	2043/12/22	\$525	5
YD63294		Active	LJ 4	Alexco Keno Hill Mining Corp. - 100%	2010/12/20	2010/12/22	2043/12/22	\$525	5
YD63295		Active	LJ 5	Alexco Keno Hill Mining Corp. - 100%	2010/12/20	2010/12/22	2043/12/22	\$525	5
YD63296		Active	LJ 6	Alexco Keno Hill Mining Corp. - 100%	2010/12/20	2010/12/22	2043/12/22	\$525	5
YD63297		Active	LJ 7	Alexco Keno Hill Mining Corp. - 100%	2010/12/20	2010/12/22	2043/12/22	\$525	5
YD63298		Active	LJ 8	Alexco Keno Hill Mining Corp. - 100%	2010/12/20	2010/12/22	2043/12/22	\$525	5
YD63299		Active	LJ 9	Alexco Keno Hill Mining Corp. - 100%	2010/12/20	2010/12/22	2043/12/22	\$525	5
YC90544		Pending	Lucky Baldwin	Alexco Keno Hill Mining Corp. - 100%	2016/10/21	2016/10/25	2027/10/25	\$525	5
56529	NM00502	Active	MALCOM	Alexco Keno Hill Mining Corp. - 100%	1948/06/12	1948/06/14	2025/11/28	\$210	21
YC02774		Active	Man	Alexco Keno Hill Mining Corp. - 100%	2001/07/09	2001/07/10	2030/12/31	\$525	5
YC32221		Active	Mom 1	Alexco Keno Hill Mining Corp. - 100%	2004/08/19	2004/08/23	2025/12/31	\$525	5
YC32222		Active	Mom 2	Alexco Keno Hill Mining Corp. - 100%	2004/08/19	2004/08/23	2025/12/31	\$525	5
YC32223		Active	Mom 3	Alexco Keno Hill Mining Corp. - 100%	2004/08/19	2004/08/23	2025/12/31	\$525	5
YC32224		Active	Mom 4	Alexco Keno Hill Mining Corp. - 100%	2004/08/19	2004/08/23	2025/12/31	\$525	5
YC32225		Active	Mom 5	Alexco Keno Hill Mining Corp. - 100%	2004/08/17	2004/08/23	2025/12/31	\$525	5
YC32226		Active	Mom 6	Alexco Keno Hill Mining Corp. - 100%	2004/08/17	2004/08/23	2025/12/31	\$525	5
YC32227		Active	Mom 7	Alexco Keno Hill Mining Corp. - 100%	2004/08/18	2004/08/23	2025/12/31	\$525	5
YC32228		Active	Mom 8	Alexco Keno Hill Mining Corp. - 100%	2004/08/18	2004/08/23	2025/12/31	\$525	5
YC90541		Active	Nifty Fourteen	Alexco Keno Hill Mining Corp. - 100%	2017/08/12	2017/08/15	2028/08/15	\$525	5
YC39585		Active	No name	Alexco Keno Hill Mining Corp. - 100%	2005/08/24	2005/09/01	2024/12/31	\$525	5
YC57135		Active	O No Fr.	Alexco Keno Hill Mining Corp. - 100%	2007/08/22	2007/08/22	2028/12/31	\$525	5
Y 33741		Active	O.K. 1	Alexco Keno Hill Mining Corp. - 100%	1970/12/10	1970/12/11	2042/12/31	\$525	5
Y 85968		Active	O.K. 10	Alexco Keno Hill Mining Corp. - 100%	1973/10/02	1973/10/10	2042/12/31	\$525	5
Y 33742		Active	O.K. 2	Alexco Keno Hill Mining Corp. - 100%	1970/12/10	1970/12/11	2042/12/31	\$525	5
Y 56174		Active	O.K. 3	Alexco Keno Hill Mining Corp. - 100%	1971/09/11	1971/09/15	2042/12/31	\$525	5
Y 56175		Active	O.K. 4	Alexco Keno Hill Mining Corp. - 100%	1971/09/11	1971/09/15	2042/12/31	\$525	5
Y 85963		Active	O.K. 5	Alexco Keno Hill Mining Corp. - 100%	1973/10/02	1973/10/10	2042/12/31	\$525	5
Y 85964		Active	O.K. 6	Alexco Keno Hill Mining Corp. - 100%	1973/10/02	1973/10/10	2042/12/31	\$525	5
Y 85965		Active	O.K. 7	Alexco Keno Hill Mining Corp. - 100%	1973/10/02	1973/10/10	2042/12/31	\$525	5

Grant	Lease	Status	Claim Name	Owner	Staked	Recorded	Expiry	Renewal Cost per Term (CAD)	Term (Years)
Y 85966		Active	O.K. 8	Alexco Keno Hill Mining Corp. - 100%	1973/10/02	1973/10/10	2042/12/31	\$525	5
Y 85967		Active	O.K. 9	Alexco Keno Hill Mining Corp. - 100%	1973/10/02	1973/10/10	2042/12/31	\$525	5
YC01994		Active	One	Alexco Keno Hill Mining Corp. - 100%	1999/09/23	1999/09/28	2028/09/09	\$525	5
59313		Active	Paddy	Alexco Keno Hill Mining Corp. - 100%	1949/06/29	1949/07/08	2043/12/31	\$525	5
83253		Active	Paddy 2	Alexco Keno Hill Mining Corp. - 100%	1963/10/09	1963/10/16	2043/12/31	\$525	5
83254		Active	Paddy 3	Alexco Keno Hill Mining Corp. - 100%	1963/10/09	1963/10/16	2043/12/31	\$525	5
83721		Active	Paddy 4	Alexco Keno Hill Mining Corp. - 100%	1964/10/25	1964/10/26	2043/12/31	\$525	5
83722		Active	Paddy 5	Alexco Keno Hill Mining Corp. - 100%	1964/10/25	1964/10/26	2043/12/31	\$525	5
55588	NM00295	Active	PRO	Alexco Keno Hill Mining Corp. - 100%	1946/10/08	1947/03/28	2025/02/23	\$210	21
59275	NM00541	Active	QUAIL	Alexco Keno Hill Mining Corp. - 100%	1949/06/13	1949/06/22	2027/11/02	\$210	21
59824	NM00547	Active	QUAIL FRACTION	Alexco Keno Hill Mining Corp. - 100%	1950/09/22	1950/10/02	2027/11/02	\$210	21
56522	NM00893	Active	QUEST	Alexco Keno Hill Mining Corp. - 100%	1948/06/05	1948/06/08	2042/06/19	\$210	21
59273	NM00894	Active	QUILL	Alexco Keno Hill Mining Corp. - 100%	1949/06/12	1949/06/21	2042/06/19	\$210	21
55586	NM00293	Active	REX	Alexco Keno Hill Mining Corp. - 100%	1946/10/08	1947/03/28	2025/02/23	\$210	21
16350	NM00874	Active	RING	Alexco Keno Hill Mining Corp. - 100%	1927/07/31	1927/08/27	2041/08/19	\$210	21
59683	NM00546	Active	ROCK	Alexco Keno Hill Mining Corp. - 100%	1950/09/11	1950/09/19	2027/11/02	\$210	21
13009	NM00199	Active	SMILES	Alexco Keno Hill Mining Corp. - 100%	1920/02/13	1920/04/28	2028/07/29	\$210	21
YC90547		Active	Snowdrift Fr. 17	Alexco Keno Hill Mining Corp. - 100%	2011/08/31	2011/09/02	2041/12/31	\$525	5
55446	NM00536	Active	SOL	Alexco Keno Hill Mining Corp. - 100%	1946/08/20	1946/08/21	2027/11/02	\$210	21
55445	NM00535	Active	SOLOMAN	Alexco Keno Hill Mining Corp. - 100%	1946/08/16	1946/08/16	2027/11/02	\$210	21
YC32218		Active	Son 1	Alexco Keno Hill Mining Corp. - 100%	2004/08/17	2004/08/23	2025/12/31	\$525	5
YC32219		Active	Son 2	Alexco Keno Hill Mining Corp. - 100%	2004/08/17	2004/08/23	2025/12/31	\$525	5
YC32220		Active	Son 3	Alexco Keno Hill Mining Corp. - 100%	2004/08/17	2004/08/23	2025/12/31	\$525	5
YC39676		Active	Son 4	Alexco Keno Hill Mining Corp. - 100%	2005/08/26	2005/09/01	2024/12/31	\$525	5
YC39586		Active	Son 5	Alexco Keno Hill Mining Corp. - 100%	2005/09/08	2005/09/12	2024/12/31	\$525	5
YC39587		Active	Son 6	Alexco Keno Hill Mining Corp. - 100%	2005/09/08	2005/09/12	2024/12/31	\$525	5
YC02773		Active	Spider	Alexco Keno Hill Mining Corp. - 100%	2001/07/06	2001/07/10	2030/12/31	\$525	5
55433	NM00534	Active	SUNRISE	Alexco Keno Hill Mining Corp. - 100%	1946/06/15	1946/06/20	2027/11/02	\$210	21
61601	NM00552	Active	TARM	Alexco Keno Hill Mining Corp. - 100%	1951/05/13	1951/05/25	2027/11/02	\$210	21

Grant	Lease	Status	Claim Name	Owner	Staked	Recorded	Expiry	Renewal Cost per Term (CAD)	Term (Years)
55520	NM00538	Active	THUNDER BIRD	Alexco Keno Hill Mining Corp. - 100%	1946/09/15	1947/02/04	2027/11/02	\$210	21
Y 31586		Active	Toni 1	Alexco Keno Hill Mining Corp. - 100%	1968/11/29	1968/12/02	2042/12/31	\$525	5
Y 31587		Active	Toni 2	Alexco Keno Hill Mining Corp. - 100%	1968/11/29	1968/12/02	2042/12/31	\$525	5
13258	NM00211	Active	VANGUARD FRAC.	Alexco Keno Hill Mining Corp. - 100%	1920/06/19	1920/07/28	2028/09/13	\$210	21
55426	NM00532	Active	WILDCAT	Alexco Keno Hill Mining Corp. - 100%	1946/05/25	1946/06/03	2027/11/02	\$210	21
55519	NM00537	Active	WILLOW	Alexco Keno Hill Mining Corp. - 100%	1946/09/05	1947/02/04	2027/11/02	\$210	21
YB28942		Active	DOUG 1	Alexco Keno Hill Mining Corp. - 49%, Banyan Gold Corporation - 51%	1992/08/31	1992/09/04	2048/12/31	\$525	5
YB28943		Active	DOUG 2	Alexco Keno Hill Mining Corp. - 49%, Banyan Gold Corporation - 51%	1992/08/31	1992/09/04	2048/12/31	\$525	5
YB28944		Active	DOUG 3	Alexco Keno Hill Mining Corp. - 49%, Banyan Gold Corporation - 51%	1992/08/31	1992/09/04	2048/12/31	\$525	5
YB28945		Active	DOUG 4	Alexco Keno Hill Mining Corp. - 49%, Banyan Gold Corporation - 51%	1992/08/31	1992/09/04	2048/12/31	\$525	5
YB28998		Active	Doug 5	Alexco Keno Hill Mining Corp. - 49%, Banyan Gold Corporation - 51%	1992/09/10	1992/09/25	2048/12/31	\$525	5
YB28999		Active	Doug 6	Alexco Keno Hill Mining Corp. - 49%, Banyan Gold Corporation - 51%	1992/09/10	1992/09/25	2048/12/31	\$525	5
YB29000		Active	Doug 7	Alexco Keno Hill Mining Corp. - 49%, Banyan Gold Corporation - 51%	1992/09/10	1992/09/25	2048/12/31	\$525	5
YB29001		Active	Doug 8	Alexco Keno Hill Mining Corp. - 49%, Banyan Gold Corporation - 51%	1992/09/10	1992/09/25	2048/12/31	\$525	5
YB29395		Active	DOUG 9	Alexco Keno Hill Mining Corp. - 49%, Banyan Gold Corporation - 51%	1992/11/18	1992/11/18	2048/12/31	\$525	5
YC02325		Active	Hoito 3	Alexco Keno Hill Mining Corp. - 49%, Banyan Gold Corporation - 51%	1999/12/12	1999/12/29	2046/12/29	\$525	5
YC02327		Active	Hoito 5	Alexco Keno Hill Mining Corp. - 49%, Banyan Gold Corporation - 51%	1999/12/12	1999/12/29	2046/12/29	\$525	5
YC02329		Active	Hoito 7	Alexco Keno Hill Mining Corp. - 49%, Banyan Gold Corporation - 51%	1999/12/12	1999/12/29	2046/12/29	\$525	5
YB29440		Active	JARRET 1	Alexco Keno Hill Mining Corp. - 49%, Banyan Gold Corporation - 51%	1992/12/18	1992/12/18	2048/12/31	\$525	5
YC01768		Active	Jarret 2	Alexco Keno Hill Mining Corp. - 49%, Banyan Gold Corporation - 51%	1999/04/24	1999/04/30	2044/12/31	\$525	5
YC42603		Active	K 55	Alexco Keno Hill Mining Corp. - 49%, Banyan Gold Corporation - 51%	2005/12/05	2005/12/15	2027/12/15	\$525	5
YC42604		Active	K 56	Alexco Keno Hill Mining Corp. - 49%, Banyan Gold Corporation - 51%	2005/12/05	2005/12/15	2027/12/15	\$525	5
YB64191		Active	Lakehead 10	Alexco Keno Hill Mining Corp. - 49%, Banyan Gold Corporation - 51%	1995/06/27	1995/06/28	2047/12/31	\$525	5

Grant	Lease	Status	Claim Name	Owner	Staked	Recorded	Expiry	Renewal Cost per Term (CAD)	Term (Years)
YB64194		Active	Lakehead 11	Alexco Keno Hill Mining Corp. - 49%, Banyan Gold Corporation - 51%	1995/06/29	1995/06/30	2047/12/31	\$525	5
YB64195		Active	Lakehead 12	Alexco Keno Hill Mining Corp. - 49%, Banyan Gold Corporation - 51%	1995/06/29	1995/06/30	2047/12/31	\$525	5
YB64196		Active	Lakehead 13	Alexco Keno Hill Mining Corp. - 49%, Banyan Gold Corporation - 51%	1995/06/29	1995/06/30	2047/12/31	\$525	5
YB64192		Active	Lakehead 3	Alexco Keno Hill Mining Corp. - 49%, Banyan Gold Corporation - 51%	1995/06/29	1995/06/30	2047/12/31	\$525	5
YB64193		Active	Lakehead 4	Alexco Keno Hill Mining Corp. - 49%, Banyan Gold Corporation - 51%	1995/06/29	1995/06/30	2047/12/31	\$525	5
YB64186		Active	Lakehead 5	Alexco Keno Hill Mining Corp. - 49%, Banyan Gold Corporation - 51%	1995/06/27	1995/06/28	2047/12/31	\$525	5
YB64187		Active	Lakehead 6	Alexco Keno Hill Mining Corp. - 49%, Banyan Gold Corporation - 51%	1995/06/27	1995/06/28	2047/12/31	\$525	5
YB64188		Active	Lakehead 7	Alexco Keno Hill Mining Corp. - 49%, Banyan Gold Corporation - 51%	1995/06/27	1995/06/28	2047/12/31	\$525	5
YB64189		Active	Lakehead 8	Alexco Keno Hill Mining Corp. - 49%, Banyan Gold Corporation - 51%	1995/06/27	1995/06/28	2047/12/31	\$525	5
YB64190		Active	Lakehead 9	Alexco Keno Hill Mining Corp. - 49%, Banyan Gold Corporation - 51%	1995/06/27	1995/06/28	2047/12/31	\$525	5
YB29002		Active	Mary 1	Alexco Keno Hill Mining Corp. - 49%, Banyan Gold Corporation - 51%	1902/09/10	1992/09/25	2046/12/31	\$525	5
YB29003		Active	Mary 2	Alexco Keno Hill Mining Corp. - 49%, Banyan Gold Corporation - 51%	1992/09/10	1992/09/25	2046/12/31	\$525	5
YB29004		Active	Mary 3	Alexco Keno Hill Mining Corp. - 49%, Banyan Gold Corporation - 51%	1902/09/10	1992/09/25	2050/12/31	\$525	5
YB29005		Active	Mary 4	Alexco Keno Hill Mining Corp. - 49%, Banyan Gold Corporation - 51%	1902/09/10	1992/09/25	2050/12/31	\$525	5
YB29394		Active	MARY 6	Alexco Keno Hill Mining Corp. - 49%, Banyan Gold Corporation - 51%	1992/11/18	1992/11/18	2046/12/31	\$525	5
YC10995		Active	Mary A 0	Alexco Keno Hill Mining Corp. - 49%, Banyan Gold Corporation - 51%	2003/08/19	2003/09/02	2043/12/31	\$525	5
YC10996		Active	Mary B 0	Alexco Keno Hill Mining Corp. - 49%, Banyan Gold Corporation - 51%	2003/08/19	2003/09/02	2043/12/31	\$525	5
YC10897		Active	North F.	Alexco Keno Hill Mining Corp. - 49%, Banyan Gold Corporation - 51%	2003/08/07	2003/08/08	2043/12/31	\$525	5
YC01212		Active	South F	Alexco Keno Hill Mining Corp. - 49%, Banyan Gold Corporation - 51%	1998/07/04	1998/07/06	2042/12/31	\$525	5
YC02322		Active	Twins 7	Alexco Keno Hill Mining Corp. - 49%, Banyan Gold Corporation - 51%	1999/12/14	1999/12/29	2043/12/29	\$525	5
YC10946		Active	Wedge 1	Alexco Keno Hill Mining Corp. - 49%, Banyan Gold Corporation - 51%	2003/09/09	2003/09/09	2042/12/31	\$525	5

Grant	Lease	Status	Claim Name	Owner	Staked	Recorded	Expiry	Renewal Cost per Term (CAD)	Term (Years)
YC10993		Active	Wedge 2	Alexco Keno Hill Mining Corp. - 49%, Banyan Gold Corporation - 51%	2003/09/10	2003/09/18	2043/12/31	\$525	5
YC10994		Active	Wedge 3	Alexco Keno Hill Mining Corp. - 49%, Banyan Gold Corporation - 51%	2003/09/10	2003/09/18	2043/12/31	\$525	5
14871	NM00895	Active	ALEXANDRA	Alexco Keno Hill Mining Corp. - 100%	1923/08/19	1923/10/12	2042/04/29	\$210	21
59665	NM00904	Active	CASA	Alexco Keno Hill Mining Corp. - 100%	1950/08/08	1950/08/11	2042/04/29	\$210	21
38815	NM00899	Active	EAGLE 1	Alexco Keno Hill Mining Corp. - 100%	1934/10/07	1934/11/14	2042/04/29	\$210	21
38811	NM00898	Active	EAGLE 2	Alexco Keno Hill Mining Corp. - 100%	1934/10/03	1934/11/12	2042/04/29	\$210	21
16171	NM00897	Active	EAGLE FRAC.	Alexco Keno Hill Mining Corp. - 100%	1926/06/13	1926/07/13	2042/04/29	\$210	21
59668	NM00907	Active	GATO	Alexco Keno Hill Mining Corp. - 100%	1950/08/08	1950/08/11	2042/04/29	\$210	21
55482	NM00900	Active	JEAN	Alexco Keno Hill Mining Corp. - 100%	1946/09/04	1947/01/24	2042/04/29	\$210	21
59666	NM00905	Active	LOMA	Alexco Keno Hill Mining Corp. - 100%	1950/08/08	1950/08/11	2042/04/29	\$210	21
14873	NM00896	Active	NATHALIE	Alexco Keno Hill Mining Corp. - 100%	1923/08/19	1923/10/12	2042/04/29	\$210	21
59662	NM00901	Active	NINA	Alexco Keno Hill Mining Corp. - 100%	1950/08/07	1950/08/11	2042/04/29	\$210	21
59669	NM00908	Active	PAVO	Alexco Keno Hill Mining Corp. - 100%	1950/08/08	1950/08/11	2042/04/29	\$210	21
59664	NM00903	Active	PERO	Alexco Keno Hill Mining Corp. - 100%	1950/08/08	1950/08/11	2042/04/29	\$210	21
59667	NM00906	Active	PORCO	Alexco Keno Hill Mining Corp. - 100%	1950/08/08	1950/08/11	2042/04/29	\$210	21
59663	NM00902	Active	TORO	Alexco Keno Hill Mining Corp. - 100%	1950/08/07	1950/08/11	2042/04/29	\$210	21
56501	NM00916	Active	83	Elsa Reclamation & Development Company Ltd. - 100%	1947/09/17	1947/09/24	2042/07/24	\$210	21
56502	NM00917	Active	A.A.	Elsa Reclamation & Development Company Ltd. - 100%	1947/09/17	1947/09/24	2042/07/24	\$210	21
55548	NM00322	Active	ACE-HI	Elsa Reclamation & Development Company Ltd. - 100%	1946/10/17	1947/02/13	2025/02/08	\$210	21
55549	NM00323	Active	ACE-HI 1	Elsa Reclamation & Development Company Ltd. - 100%	1946/10/17	1947/02/13	2025/02/08	\$210	21
55559	NM00331	Active	ACE-HI 10	Elsa Reclamation & Development Company Ltd. - 100%	1946/10/17	1947/02/14	2025/02/08	\$210	21
55560	NM00332	Active	ACE-HI 11	Elsa Reclamation & Development Company Ltd. - 100%	1946/10/17	1947/02/14	2025/02/08	\$210	21
55550	NM00324	Active	ACE-HI 2	Elsa Reclamation & Development Company Ltd. - 100%	1946/10/17	1947/02/13	2025/02/08	\$210	21
55552	NM00325	Active	ACE-HI 4	Elsa Reclamation & Development Company Ltd. - 100%	1946/10/17	1947/02/14	2025/02/08	\$210	21
55553	NM00326	Active	ACE-HI 5	Elsa Reclamation & Development Company Ltd. - 100%	1946/10/17	1947/02/14	2025/02/08	\$210	21
55555	NM00327	Active	ACE-HI 6	Elsa Reclamation & Development Company Ltd. - 100%	1946/10/17	1947/02/14	2025/02/08	\$210	21
55556	NM00328	Active	ACE-HI 7	Elsa Reclamation & Development Company Ltd. - 100%	1946/10/17	1947/02/14	2025/02/08	\$210	21
55557	NM00329	Active	ACE-HI 8	Elsa Reclamation & Development Company Ltd. - 100%	1946/10/17	1947/02/14	2025/02/08	\$210	21

Grant	Lease	Status	Claim Name	Owner	Staked	Recorded	Expiry	Renewal Cost per Term (CAD)	Term (Years)
55558	NM00330	Active	ACE-HI 9	Elsa Reclamation & Development Company Ltd. - 100%	1946/10/17	1947/02/14	2025/02/08	\$210	21
56575	NM00986	Active	ACRE FRACTION	Elsa Reclamation & Development Company Ltd. - 100%	1948/07/14	1948/07/21	2043/06/12	\$210	21
14858		Active	ADA	Elsa Reclamation & Development Company Ltd. - 100%	1923/07/30	1923/08/30	2027/12/31	\$525	5
83011	NM00593	Active	ADAM FRACTION	Elsa Reclamation & Development Company Ltd. - 100%	1963/06/29	1963/07/09	2027/11/02	\$210	21
55477	NM00809	Active	ADONAIS	Elsa Reclamation & Development Company Ltd. - 100%	1946/08/31	1947/01/24	2038/12/15	\$210	21
12840	NM00361	Active	AJAX	Elsa Reclamation & Development Company Ltd. - 100%	1919/09/09	1919/10/28	2025/04/30	\$210	21
14466	NM00827	Active	AJAX	Elsa Reclamation & Development Company Ltd. - 100%	1921/09/30	1921/12/07	2039/08/18	\$210	21
80178	NM00499	Active	ALBERTA L	Elsa Reclamation & Development Company Ltd. - 100%	1956/12/07	1956/12/13	2025/11/26	\$210	21
55573	NM00276	Active	ALICE	Elsa Reclamation & Development Company Ltd. - 100%	1946/10/25	1947/02/17	2029/04/18	\$210	21
59013	NM00930	Active	ALICE	Elsa Reclamation & Development Company Ltd. - 100%	1948/08/28	1948/09/01	2042/08/08	\$210	21
62317	NM00470	Active	ALICE 1	Elsa Reclamation & Development Company Ltd. - 100%	1953/07/25	1953/08/05	2025/11/26	\$210	21
62318	NM00471	Active	ALICE 2	Elsa Reclamation & Development Company Ltd. - 100%	1953/07/25	1953/08/05	2025/11/26	\$210	21
YB29727		Active	ALLA 4	Elsa Reclamation & Development Company Ltd. - 100%	1993/03/15	1993/03/19	2044/12/31	\$525	5
81223	NM00651	Active	ANDY	Elsa Reclamation & Development Company Ltd. - 100%	1962/06/21	1962/06/26	2031/03/12	\$210	21
13108	NM00910	Active	ANEROID	Elsa Reclamation & Development Company Ltd. - 100%	1920/04/27	1920/06/10	2042/07/18	\$210	21
12909	NM00642	Active	ANTHONY	Elsa Reclamation & Development Company Ltd. - 100%	1919/10/13	1919/12/17	2030/03/24	\$210	21
56443	NM00811	Active	APEX FR.	Elsa Reclamation & Development Company Ltd. - 100%	1947/07/11	1947/07/15	2038/12/15	\$210	21
55476	NM00808	Active	APOLLO	Elsa Reclamation & Development Company Ltd. - 100%	1946/08/31	1947/01/23	2038/12/15	\$210	21
14089	NM00692	Active	ARCTIC	Elsa Reclamation & Development Company Ltd. - 100%	1921/05/03	1921/07/26	2035/12/19	\$210	21
16589	NM00351	Active	ARDELLE	Elsa Reclamation & Development Company Ltd. - 100%	1925/06/12	1925/07/23	2025/03/30	\$210	21
55474	NM00806	Active	ARETHUSA	Elsa Reclamation & Development Company Ltd. - 100%	1946/08/31	1947/01/23	2038/12/15	\$210	21
16561	NM00753	Active	ARIZONA	Elsa Reclamation & Development Company Ltd. - 100%	1925/06/02	1925/06/30	2037/01/27	\$210	21
14225	NM00966	Active	ARNOLD	Elsa Reclamation & Development Company Ltd. - 100%	1921/07/18	1921/09/24	2043/05/07	\$210	21
55475	NM00807	Active	ARTEMIS	Elsa Reclamation & Development Company Ltd. - 100%	1946/08/31	1947/01/23	2038/12/15	\$210	21
38819	NM00979	Active	ASTORIA	Elsa Reclamation & Development Company Ltd. - 100%	1934/10/28	1934/11/19	2043/06/12	\$210	21
14998	NM00701	Active	ATLANTIC	Elsa Reclamation & Development Company Ltd. - 100%	1924/06/18	1924/07/14	2036/01/29	\$210	21
38687	NM00829	Active	AUGUST	Elsa Reclamation & Development Company Ltd. - 100%	1930/08/13	1930/09/16	2039/08/18	\$210	21
62200	NM00370	Active	B & H	Elsa Reclamation & Development Company Ltd. - 100%	1952/07/25	1952/08/04	2025/04/30	\$210	21
59373	NM00195	Active	BANKER	Elsa Reclamation & Development Company Ltd. - 100%	1949/07/28	1949/07/29	2028/06/16	\$210	21

Grant	Lease	Status	Claim Name	Owner	Staked	Recorded	Expiry	Renewal Cost per Term (CAD)	Term (Years)
59374	NM00196	Active	BANKER 1	Elsa Reclamation & Development Company Ltd. - 100%	1949/07/28	1949/07/29	2028/06/16	\$210	21
59375	NM00197	Active	BANKER 2	Elsa Reclamation & Development Company Ltd. - 100%	1949/07/28	1949/07/29	2028/06/16	\$210	21
59376	NM00198	Active	BANKER 3	Elsa Reclamation & Development Company Ltd. - 100%	1949/07/28	1949/07/29	2028/06/16	\$210	21
YB43712		Active	Barb One	Elsa Reclamation & Development Company Ltd. - 100%	1994/10/12	1994/10/12	2024/12/31	\$525	5
14446	NM00911	Active	BARKER Jr	Elsa Reclamation & Development Company Ltd. - 100%	1921/10/13	1921/12/01	2042/07/24	\$210	21
55569	NM00840	Active	BARKY	Elsa Reclamation & Development Company Ltd. - 100%	1946/10/24	1947/02/17	2040/07/27	\$210	21
15306	NM00953	Active	BEAR	Elsa Reclamation & Development Company Ltd. - 100%	1928/10/27	1928/11/29	2042/08/26	\$210	21
55048	NM00960	Active	BEE	Elsa Reclamation & Development Company Ltd. - 100%	1937/10/01	1937/10/29	2042/08/28	\$210	21
14826		Active	BELL YORK	Elsa Reclamation & Development Company Ltd. - 100%	1923/06/04	1923/07/09	2027/12/31	\$525	5
59518	NM00846	Active	BEN	Elsa Reclamation & Development Company Ltd. - 100%	1949/11/01	1949/11/01	2040/07/27	\$210	21
59474	NM00958	Active	BERRHOME	Elsa Reclamation & Development Company Ltd. - 100%	1949/08/31	1949/09/03	2042/08/26	\$210	21
59121	NM00970	Active	BERRMAC 1	Elsa Reclamation & Development Company Ltd. - 100%	1948/11/04	1948/11/10	2043/05/07	\$210	21
59122	NM00971	Active	BERRMAC 2	Elsa Reclamation & Development Company Ltd. - 100%	1948/11/04	1948/11/10	2043/05/07	\$210	21
59123	NM00972	Active	BERRMAC 3	Elsa Reclamation & Development Company Ltd. - 100%	1948/11/04	1948/11/10	2043/05/07	\$210	21
59124	NM00973	Active	BERRMAC 4	Elsa Reclamation & Development Company Ltd. - 100%	1948/11/04	1948/11/10	2043/05/07	\$210	21
59476	NM00975	Active	BERRNAT	Elsa Reclamation & Development Company Ltd. - 100%	1949/08/31	1949/09/03	2043/05/07	\$210	21
56533	NM00436	Active	BES	Elsa Reclamation & Development Company Ltd. - 100%	1948/06/09	1948/06/23	2025/11/26	\$210	21
59342	NM00845	Active	BETS	Elsa Reclamation & Development Company Ltd. - 100%	1949/07/14	1949/07/19	2040/07/27	\$210	21
56524	NM00918	Active	BETTY	Elsa Reclamation & Development Company Ltd. - 100%	1948/06/05	1948/06/11	2042/07/24	\$210	21
38831	NM00980	Active	BILLYS	Elsa Reclamation & Development Company Ltd. - 100%	1935/04/25	1935/05/15	2043/06/12	\$210	21
55371	NM00365	Active	BINGO	Elsa Reclamation & Development Company Ltd. - 100%	1945/07/20	1945/10/25	2025/04/30	\$210	21
14084	NM00695	Active	BIRMINGHAM	Elsa Reclamation & Development Company Ltd. - 100%	1921/05/03	1921/07/25	2036/01/15	\$210	21
12869	NM00994	Active	BLACK CAP	Elsa Reclamation & Development Company Ltd. - 100%	1919/09/27	1919/11/12	2043/11/19	\$210	21
13480	NM00763	Active	BLACK MAGGIE	Elsa Reclamation & Development Company Ltd. - 100%	1920/08/13	1920/10/13	2037/09/03	\$210	21
62272	NM00344	Active	BLOOD	Elsa Reclamation & Development Company Ltd. - 100%	1952/09/13	1952/09/17	2025/02/15	\$210	21
13143	NM00617	Active	BLUE BELL	Elsa Reclamation & Development Company Ltd. - 100%	1920/05/07	1920/06/16	2030/01/31	\$210	21
59160	NM00841	Active	BLUE BIRD	Elsa Reclamation & Development Company Ltd. - 100%	1948/11/11	1948/11/22	2040/07/27	\$210	21
59366	NM00209	Active	BLUE FOX 10	Elsa Reclamation & Development Company Ltd. - 100%	1949/07/15	1949/07/19	2028/07/20	\$210	21
59343	NM00202	Active	BLUE FOX 2	Elsa Reclamation & Development Company Ltd. - 100%	1949/07/15	1949/07/19	2028/07/27	\$210	21

Grant	Lease	Status	Claim Name	Owner	Staked	Recorded	Expiry	Renewal Cost per Term (CAD)	Term (Years)
59359	NM00201	Active	BLUE FOX 3	Elsa Reclamation & Development Company Ltd. - 100%	1949/07/15	1949/07/19	2028/07/27	\$210	21
59360	NM00203	Active	BLUE FOX 4	Elsa Reclamation & Development Company Ltd. - 100%	1949/07/15	1949/07/19	2028/07/20	\$210	21
59361	NM00204	Active	BLUE FOX 5	Elsa Reclamation & Development Company Ltd. - 100%	1949/07/15	1949/07/19	2028/07/20	\$210	21
59362	NM00205	Active	BLUE FOX 6	Elsa Reclamation & Development Company Ltd. - 100%	1949/07/15	1949/07/19	2028/07/20	\$210	21
59363	NM00206	Active	BLUE FOX 7	Elsa Reclamation & Development Company Ltd. - 100%	1949/07/15	1949/07/19	2028/07/20	\$210	21
59364	NM00207	Active	BLUE FOX 8	Elsa Reclamation & Development Company Ltd. - 100%	1949/07/15	1949/07/19	2028/07/20	\$210	21
59365	NM00208	Active	BLUE FOX 9	Elsa Reclamation & Development Company Ltd. - 100%	1949/07/15	1949/07/19	2028/07/20	\$210	21
13122	NM00880	Active	BLUE ROCK	Elsa Reclamation & Development Company Ltd. - 100%	1920/04/28	1920/06/12	2041/11/14	\$210	21
13151	NM00636	Active	BLUE STONE	Elsa Reclamation & Development Company Ltd. - 100%	1920/05/07	1920/06/16	2029/12/31	\$210	21
59351	NM00210	Active	BLUE-FOX 1	Elsa Reclamation & Development Company Ltd. - 100%	1949/07/15	1949/07/19	2028/07/27	\$210	21
55394		Active	BOB	Elsa Reclamation & Development Company Ltd. - 100%	1946/02/07	1946/03/05	2027/12/31	\$525	5
59543	NM01008	Active	BOB	Elsa Reclamation & Development Company Ltd. - 100%	1950/04/14	1950/05/01	2044/02/09	\$210	21
59494	NM01011	Active	BOBBIE 10	Elsa Reclamation & Development Company Ltd. - 100%	1949/09/03	1949/09/06	2044/02/12	\$210	21
59486	NM00456	Active	BOBBIE 2	Elsa Reclamation & Development Company Ltd. - 100%	1949/09/03	1949/09/06	2025/11/26	\$210	21
59487	NM00457	Active	BOBBIE 3	Elsa Reclamation & Development Company Ltd. - 100%	1949/09/03	1949/09/06	2025/11/26	\$210	21
59488	NM00458	Active	BOBBIE 4	Elsa Reclamation & Development Company Ltd. - 100%	1949/09/03	1949/09/06	2025/11/26	\$210	21
59491	NM01009	Active	BOBBIE 7	Elsa Reclamation & Development Company Ltd. - 100%	1949/09/03	1949/09/06	2044/02/12	\$210	21
59493	NM01010	Active	BOBBIE 9	Elsa Reclamation & Development Company Ltd. - 100%	1949/09/03	1949/09/06	2044/02/12	\$210	21
55365	NM00275	Active	BOKA	Elsa Reclamation & Development Company Ltd. - 100%	1945/07/08	1945/10/25	2029/04/18	\$210	21
15250	NM00914	Active	BOYLE	Elsa Reclamation & Development Company Ltd. - 100%	1928/07/15	1928/08/06	2042/07/24	\$210	21
59026	NM00920	Active	BOYLE	Elsa Reclamation & Development Company Ltd. - 100%	1948/09/11	1948/09/13	2042/07/24	\$210	21
15249	NM00242	Active	BRIDGETTE	Elsa Reclamation & Development Company Ltd. - 100%	1928/07/15	1928/08/06	2029/02/28	\$210	21
59316	NM00287	Active	BRISTOL	Elsa Reclamation & Development Company Ltd. - 100%	1949/07/11	1949/07/19	2024/06/27	\$210	21
12988	NM00274	Active	BRITANNIA	Elsa Reclamation & Development Company Ltd. - 100%	1920/03/10	1920/04/09	2029/04/18	\$210	21
59041	NM00987	Active	BUCKEYE	Elsa Reclamation & Development Company Ltd. - 100%	1948/09/20	1948/09/21	2043/06/12	\$210	21
59795	NM00572	Active	BUCKO	Elsa Reclamation & Development Company Ltd. - 100%	1950/09/29	1950/10/02	2027/11/02	\$210	21
55513	NM00311	Active	BUCONJO 10	Elsa Reclamation & Development Company Ltd. - 100%	1946/09/15	1947/02/03	2025/01/31	\$210	21
55514	NM00312	Active	BUCONJO 11	Elsa Reclamation & Development Company Ltd. - 100%	1946/09/15	1947/02/03	2025/01/31	\$210	21
55515	NM00313	Active	BUCONJO 12	Elsa Reclamation & Development Company Ltd. - 100%	1946/09/19	1947/02/03	2025/01/31	\$210	21

Grant	Lease	Status	Claim Name	Owner	Staked	Recorded	Expiry	Renewal Cost per Term (CAD)	Term (Years)
55509	NM00307	Active	BUCONJO 6	Elsa Reclamation & Development Company Ltd. - 100%	1946/09/14	1947/02/01	2025/01/31	\$210	21
55511	NM00309	Active	BUCONJO 8	Elsa Reclamation & Development Company Ltd. - 100%	1946/09/15	1947/02/03	2025/01/31	\$210	21
55512	NM00310	Active	BUCONJO 9	Elsa Reclamation & Development Company Ltd. - 100%	1946/09/15	1947/02/03	2025/01/31	\$210	21
14884	NM00912	Active	BUDDY	Elsa Reclamation & Development Company Ltd. - 100%	1923/09/02	1923/10/22	2042/07/24	\$210	21
13454	NM00772	Active	BULL FROG	Elsa Reclamation & Development Company Ltd. - 100%	1920/07/29	1920/10/02	2038/03/30	\$210	21
YA39498		Active	Bulldozer 1	Elsa Reclamation & Development Company Ltd. - 100%	1979/04/03	1979/04/04	2026/12/31	\$525	5
83133	NM00656	Active	Bunk	Elsa Reclamation & Development Company Ltd. - 100%	1963/08/12	1963/08/13	2031/03/12	\$210	21
13058	NM00863	Active	BUNNY	Elsa Reclamation & Development Company Ltd. - 100%	1920/04/03	1920/05/11	2041/04/25	\$210	21
16166	NM00941	Active	BUNNY	Elsa Reclamation & Development Company Ltd. - 100%	1926/06/08	1926/07/12	2042/08/20	\$210	21
59542	NM01007	Active	BUNT	Elsa Reclamation & Development Company Ltd. - 100%	1950/04/14	1950/05/01	2044/02/09	\$210	21
14445	NM00950	Active	BUSH	Elsa Reclamation & Development Company Ltd. - 100%	1921/10/11	1921/12/01	2042/08/26	\$210	21
59420	NM00955	Active	CACHI 1	Elsa Reclamation & Development Company Ltd. - 100%	1949/07/27	1949/08/10	2042/08/26	\$210	21
59421	NM00956	Active	CACHI 2	Elsa Reclamation & Development Company Ltd. - 100%	1949/07/27	1949/08/10	2042/08/26	\$210	21
59422	NM00957	Active	CACHI 3	Elsa Reclamation & Development Company Ltd. - 100%	1949/07/27	1949/08/10	2042/08/26	\$210	21
62341	NM00288	Active	CAKE	Elsa Reclamation & Development Company Ltd. - 100%	1953/11/11	1953/11/20	2024/06/27	\$210	21
62282	NM00280	Active	CALF	Elsa Reclamation & Development Company Ltd. - 100%	1952/09/21	1952/10/02	2029/04/18	\$210	21
13114	NM00290	Active	CALUMET 1	Elsa Reclamation & Development Company Ltd. - 100%	1920/04/27	1920/06/11	2024/08/15	\$210	21
15319	NM00243	Active	CALUMET 2	Elsa Reclamation & Development Company Ltd. - 100%	1929/03/01	1929/03/27	2029/02/28	\$210	21
59249	NM00268	Active	CAMARRILA	Elsa Reclamation & Development Company Ltd. - 100%	1949/05/28	1949/05/31	2029/01/18	\$210	21
59248	NM00267	Active	CAMEO	Elsa Reclamation & Development Company Ltd. - 100%	1949/05/28	1949/05/31	2029/01/18	\$210	21
13175	NM00666	Active	CAMOROTE	Elsa Reclamation & Development Company Ltd. - 100%	1920/05/05	1920/06/19	2033/10/31	\$210	21
55484	NM00967	Active	CANADA	Elsa Reclamation & Development Company Ltd. - 100%	1946/08/26	1947/01/24	2043/05/07	\$210	21
12970	NM00873	Active	CANADIAN	Elsa Reclamation & Development Company Ltd. - 100%	1919/09/19	1920/03/04	2041/08/14	\$210	21
59250	NM00269	Active	CAPSTAN	Elsa Reclamation & Development Company Ltd. - 100%	1949/05/28	1949/05/31	2029/01/18	\$210	21
12878	NM00831	Active	CARIBOU	Elsa Reclamation & Development Company Ltd. - 100%	1919/09/06	1919/11/26	2040/09/14	\$210	21
Y 68414		Active	Case 1	Elsa Reclamation & Development Company Ltd. - 100%	1972/08/03	1972/08/17	2043/12/31	\$525	5
Y 68415		Active	Case 2	Elsa Reclamation & Development Company Ltd. - 100%	1972/08/03	1972/08/17	2043/12/31	\$525	5
Y 68416		Active	Case 3	Elsa Reclamation & Development Company Ltd. - 100%	1972/08/07	1972/08/17	2043/12/31	\$525	5
62236	NM00403	Active	CAT	Elsa Reclamation & Development Company Ltd. - 100%	1952/08/25	1952/08/27	2025/06/12	\$210	21

Grant	Lease	Status	Claim Name	Owner	Staked	Recorded	Expiry	Renewal Cost per Term (CAD)	Term (Years)
81226	NM00653	Active	CATHY	Elsa Reclamation & Development Company Ltd. - 100%	1962/06/20	1962/06/26	2031/03/12	\$210	21
83012	NM00594	Active	CATHY FRACTION	Elsa Reclamation & Development Company Ltd. - 100%	1963/06/29	1963/07/09	2027/11/02	\$210	21
38779	NM00665	Active	CHANCE	Elsa Reclamation & Development Company Ltd. - 100%	1934/03/29	1934/04/18	2033/06/17	\$210	21
55120	NM00802	Active	CHANCE	Elsa Reclamation & Development Company Ltd. - 100%	1938/11/05	1938/11/28	2038/12/15	\$210	21
59796	NM00573	Active	CHARITY	Elsa Reclamation & Development Company Ltd. - 100%	1950/09/29	1950/10/02	2027/11/02	\$210	21
13089	NM00825	Active	CHIEF	Elsa Reclamation & Development Company Ltd. - 100%	1920/04/16	1920/06/08	2039/08/18	\$210	21
13088	NM00824	Active	CHIEF 2	Elsa Reclamation & Development Company Ltd. - 100%	1920/04/16	1920/06/08	2039/08/18	\$210	21
13092	NM00961	Active	CHIEF 3	Elsa Reclamation & Development Company Ltd. - 100%	1920/04/18	1920/06/08	2042/08/26	\$210	21
13093	NM00627	Active	CHIEF 4	Elsa Reclamation & Development Company Ltd. - 100%	1920/04/18	1920/06/09	2029/12/06	\$210	21
62284	NM00467	Active	CITY	Elsa Reclamation & Development Company Ltd. - 100%	1952/09/27	1952/10/02	2025/11/26	\$210	21
59475	NM00959	Active	CLIMBEAGLE	Elsa Reclamation & Development Company Ltd. - 100%	1949/08/31	1949/09/03	2042/08/26	\$210	21
59120	NM00954	Active	CLIMBER	Elsa Reclamation & Development Company Ltd. - 100%	1948/11/04	1948/11/10	2042/08/26	\$210	21
80358	NM00580	Active	CLOSURE	Elsa Reclamation & Development Company Ltd. - 100%	1959/07/09	1959/07/21	2027/11/02	\$210	21
55421	NM00849	Active	COMPLEX	Elsa Reclamation & Development Company Ltd. - 100%	1946/05/25	1946/08/16	2040/08/28	\$210	21
62153	NM00320	Active	CON	Elsa Reclamation & Development Company Ltd. - 100%	1952/06/14	1952/07/02	2025/02/01	\$210	21
56473	NM00601	Active	CORA	Elsa Reclamation & Development Company Ltd. - 100%	1947/08/11	1947/08/25	2028/07/22	\$210	21
55480	NM00858	Active	CORA	Elsa Reclamation & Development Company Ltd. - 100%	1946/08/26	1947/01/24	2041/02/11	\$210	21
56574	NM00978	Active	CORA 2	Elsa Reclamation & Development Company Ltd. - 100%	1948/07/09	1948/07/21	2043/06/02	\$210	21
59765	NM00892	Active	CORA Fr 2	Elsa Reclamation & Development Company Ltd. - 100%	1950/09/23	1950/09/27	2042/06/17	\$210	21
14094	NM00363	Active	CORAL	Elsa Reclamation & Development Company Ltd. - 100%	1921/05/04	1921/07/26	2025/04/30	\$210	21
55420	NM00564	Active	CROESUS	Elsa Reclamation & Development Company Ltd. - 100%	1946/05/22	1946/05/27	2027/11/02	\$210	21
13418	NM00372	Active	CUB	Elsa Reclamation & Development Company Ltd. - 100%	1920/07/26	1920/09/25	2025/05/10	\$210	21
59005	NM00509	Active	D.C.	Elsa Reclamation & Development Company Ltd. - 100%	1948/08/11	1948/08/26	2026/11/01	\$210	21
14883	NM00699	Active	DARWIN	Elsa Reclamation & Development Company Ltd. - 100%	1923/09/16	1923/10/18	2036/01/28	\$210	21
62367	NM00472	Active	DAWSON	Elsa Reclamation & Development Company Ltd. - 100%	1954/06/19	1954/06/21	2025/11/26	\$210	21
59367	NM00996	Active	DE CHUCK	Elsa Reclamation & Development Company Ltd. - 100%	1949/07/21	1949/07/25	2043/11/19	\$210	21
55315	NM00882	Active	DELIA	Elsa Reclamation & Development Company Ltd. - 100%	1944/09/22	1945/02/19	2041/11/14	\$210	21
59253	NM00270	Active	DENTON	Elsa Reclamation & Development Company Ltd. - 100%	1949/06/01	1949/06/03	2029/01/18	\$210	21
14846	NM00687	Active	DENVER	Elsa Reclamation & Development Company Ltd. - 100%	1923/07/17	1923/08/11	2035/10/14	\$210	21

Grant	Lease	Status	Claim Name	Owner	Staked	Recorded	Expiry	Renewal Cost per Term (CAD)	Term (Years)
55577	NM00277	Active	DEVON	Elsa Reclamation & Development Company Ltd. - 100%	1946/09/19	1947/03/20	2029/04/18	\$210	21
YA40163		Active	Dice 1	Elsa Reclamation & Development Company Ltd. - 100%	1979/06/14	1979/06/29	2037/12/29	\$525	5
YA40173		Active	Dice 11	Elsa Reclamation & Development Company Ltd. - 100%	1979/06/15	1979/06/29	2037/12/29	\$525	5
YA40174		Active	Dice 12	Elsa Reclamation & Development Company Ltd. - 100%	1979/06/15	1979/06/29	2037/12/29	\$525	5
YA40175		Active	Dice 13	Elsa Reclamation & Development Company Ltd. - 100%	1979/06/15	1979/06/29	2037/12/29	\$525	5
YA40176		Active	Dice 14	Elsa Reclamation & Development Company Ltd. - 100%	1979/06/15	1979/06/29	2037/12/29	\$525	5
YA40164		Active	Dice 2	Elsa Reclamation & Development Company Ltd. - 100%	1979/06/14	1979/06/29	2037/12/29	\$525	5
YA40165		Active	Dice 3	Elsa Reclamation & Development Company Ltd. - 100%	1979/06/14	1979/06/29	2037/12/29	\$525	5
YA40166		Active	Dice 4	Elsa Reclamation & Development Company Ltd. - 100%	1979/06/14	1979/06/29	2037/12/29	\$525	5
YA40167		Active	Dice 5	Elsa Reclamation & Development Company Ltd. - 100%	1979/06/14	1979/06/29	2037/12/29	\$525	5
YA40168		Active	Dice 6	Elsa Reclamation & Development Company Ltd. - 100%	1979/06/14	1979/06/29	2037/12/29	\$525	5
YA40169		Active	Dice 7	Elsa Reclamation & Development Company Ltd. - 100%	1979/06/14	1979/06/29	2037/12/29	\$525	5
YA40170		Active	Dice 8	Elsa Reclamation & Development Company Ltd. - 100%	1979/06/14	1979/06/29	2037/12/29	\$525	5
YA40171		Active	Dice 9	Elsa Reclamation & Development Company Ltd. - 100%	1979/06/15	1979/06/29	2037/12/29	\$525	5
55362	NM00430	Active	DIVIDE	Elsa Reclamation & Development Company Ltd. - 100%	1945/07/08	1945/10/25	2025/11/26	\$210	21
62283	NM00466	Active	DIVORCE	Elsa Reclamation & Development Company Ltd. - 100%	1952/09/21	1952/10/02	2025/11/26	\$210	21
55585	NM00567	Active	DIXIE	Elsa Reclamation & Development Company Ltd. - 100%	1946/11/10	1947/03/20	2027/11/02	\$210	21
14903	NM00746	Active	DIXIE	Elsa Reclamation & Development Company Ltd. - 100%	1923/10/31	1923/11/21	2036/10/07	\$210	21
55333	NM00804	Active	DOE	Elsa Reclamation & Development Company Ltd. - 100%	1945/05/23	1945/10/16	2038/12/15	\$210	21
14228	NM00765	Active	Dolly Varden	Elsa Reclamation & Development Company Ltd. - 100%	1921/07/24	1921/09/24	2038/02/15	\$210	21
61733	NM00397	Active	DON FRACTION	Elsa Reclamation & Development Company Ltd. - 100%	1951/07/07	1951/07/19	2025/06/12	\$210	21
15393	NM00559	Active	DONNIE	Elsa Reclamation & Development Company Ltd. - 100%	1929/07/17	1929/08/26	2027/11/02	\$210	21
16497	NM00669	Active	DONNIE	Elsa Reclamation & Development Company Ltd. - 100%	1924/07/20	1924/08/28	2033/11/24	\$210	21
61021	NM00574	Active	DOT	Elsa Reclamation & Development Company Ltd. - 100%	1950/10/26	1950/10/27	2027/11/02	\$210	21
62294	NM00404	Active	DOUBT	Elsa Reclamation & Development Company Ltd. - 100%	1952/10/04	1952/10/11	2025/06/12	\$210	21
55440	NM00431	Active	DOUGLAS	Elsa Reclamation & Development Company Ltd. - 100%	1946/07/01	1946/07/06	2025/11/26	\$210	21
62268	NM00340	Active	DRAKE	Elsa Reclamation & Development Company Ltd. - 100%	1952/09/13	1952/09/17	2025/02/15	\$210	21
14223	NM00927	Active	DREADNAUGHT	Elsa Reclamation & Development Company Ltd. - 100%	1921/07/17	1921/09/24	2042/08/08	\$210	21
62271	NM00343	Active	DUCE	Elsa Reclamation & Development Company Ltd. - 100%	1952/09/13	1952/09/17	2025/02/15	\$210	21

Grant	Lease	Status	Claim Name	Owner	Staked	Recorded	Expiry	Renewal Cost per Term (CAD)	Term (Years)
59468	NM00367	Active	DUNCAN 1	Elsa Reclamation & Development Company Ltd. - 100%	1949/08/17	1949/08/19	2025/04/30	\$210	21
59469	NM00368	Active	DUNCAN 2	Elsa Reclamation & Development Company Ltd. - 100%	1949/08/17	1949/08/19	2025/04/30	\$210	21
59470	NM00369	Active	DUNCAN 3	Elsa Reclamation & Development Company Ltd. - 100%	1949/08/17	1949/08/19	2025/04/30	\$210	21
55499	NM00853	Active	DUPLEX	Elsa Reclamation & Development Company Ltd. - 100%	1946/09/12	1947/02/01	2040/10/12	\$210	21
16588	NM00350	Active	EAGLE	Elsa Reclamation & Development Company Ltd. - 100%	1925/06/12	1925/07/23	2025/03/30	\$210	21
61908	NM00462	Active	EDBO	Elsa Reclamation & Development Company Ltd. - 100%	1951/08/07	1951/08/22	2025/11/26	\$210	21
61909	NM00463	Active	EDBO 2	Elsa Reclamation & Development Company Ltd. - 100%	1951/08/07	1951/08/22	2025/11/26	\$210	21
59478	NM00449	Active	EDITH-CAVELL 1	Elsa Reclamation & Development Company Ltd. - 100%	1949/09/03	1949/09/06	2025/11/26	\$210	21
59479	NM00450	Active	EDITH-CAVELL 2	Elsa Reclamation & Development Company Ltd. - 100%	1949/09/03	1949/09/06	2025/11/26	\$210	21
59480	NM00451	Active	EDITH-CAVELL 3	Elsa Reclamation & Development Company Ltd. - 100%	1949/09/03	1949/09/06	2025/11/26	\$210	21
59481	NM00452	Active	EDITH-CAVELL 4	Elsa Reclamation & Development Company Ltd. - 100%	1949/09/03	1949/09/06	2025/11/26	\$210	21
59482	NM00453	Active	EDITH-CAVELL 5	Elsa Reclamation & Development Company Ltd. - 100%	1949/09/03	1949/09/06	2025/11/26	\$210	21
59483	NM00454	Active	EDITH-CAVELL 6	Elsa Reclamation & Development Company Ltd. - 100%	1949/09/03	1949/09/06	2025/11/26	\$210	21
59484	NM00455	Active	EDITH-CAVELL 7	Elsa Reclamation & Development Company Ltd. - 100%	1949/09/03	1949/09/06	2025/11/26	\$210	21
59485	NM00597	Active	EDITH-CAVELL 8	Elsa Reclamation & Development Company Ltd. - 100%	1949/09/03	1949/09/06	2027/11/26	\$210	21
59670	NM00386	Active	EDITH-CAVELL 9	Elsa Reclamation & Development Company Ltd. - 100%	1950/08/05	1950/08/16	2025/05/22	\$210	21
16496	NM00942	Active	EFFIE	Elsa Reclamation & Development Company Ltd. - 100%	1924/08/04	1924/08/28	2042/08/20	\$210	21
56591	NM00355	Active	EILEEN	Elsa Reclamation & Development Company Ltd. - 100%	1948/08/19	1948/08/20	2025/03/30	\$210	21
59754	NM00847	Active	EILEEN	Elsa Reclamation & Development Company Ltd. - 100%	1950/09/24	1950/09/26	2040/07/27	\$210	21
55319	NM00563	Active	ELI	Elsa Reclamation & Development Company Ltd. - 100%	1944/10/12	1945/02/19	2027/11/02	\$210	21
59419	NM00570	Active	ELI 2	Elsa Reclamation & Development Company Ltd. - 100%	1949/07/20	1949/08/08	2027/11/02	\$210	21
59296	NM00932	Active	ELINOR 1	Elsa Reclamation & Development Company Ltd. - 100%	1949/06/20	1949/06/30	2042/08/08	\$210	21
59302	NM00935	Active	ELINOR 2	Elsa Reclamation & Development Company Ltd. - 100%	1949/06/20	1949/06/30	2042/08/08	\$210	21
59297	NM00933	Active	ELINOR 3	Elsa Reclamation & Development Company Ltd. - 100%	1949/06/20	1949/06/30	2042/08/08	\$210	21
59298	NM00934	Active	ELINOR 4	Elsa Reclamation & Development Company Ltd. - 100%	1949/06/20	1949/06/30	2042/08/08	\$210	21
16523	NM00773	Active	ELSA	Elsa Reclamation & Development Company Ltd. - 100%	1924/09/13	1924/10/11	2038/05/12	\$210	21
13169	NM00814	Active	ELSIE FRACTIONA	Elsa Reclamation & Development Company Ltd. - 100%	1920/05/11	1920/06/18	2039/01/01	\$210	21
55473	NM00805	Active	ENDYMION	Elsa Reclamation & Development Company Ltd. - 100%	1946/08/31	1947/01/23	2038/12/15	\$210	21
62247	NM00465	Active	ERICA	Elsa Reclamation & Development Company Ltd. - 100%	1952/09/04	1952/09/05	2025/11/26	\$210	21

Grant	Lease	Status	Claim Name	Owner	Staked	Recorded	Expiry	Renewal Cost per Term (CAD)	Term (Years)
38737	NM00915	Active	ETHEL	Elsa Reclamation & Development Company Ltd. - 100%	1932/03/22	1932/04/11	2042/07/24	\$210	21
14169	NM00691	Active	ETTA	Elsa Reclamation & Development Company Ltd. - 100%	1921/07/10	1921/09/14	2035/12/19	\$210	21
14327	NM00798	Active	EUREKA	Elsa Reclamation & Development Company Ltd. - 100%	1921/08/21	1921/10/11	2038/12/15	\$210	21
12877	NM00875	Active	EUREKA	Elsa Reclamation & Development Company Ltd. - 100%	1919/08/31	1919/11/26	2041/08/20	\$210	21
16026	NM00348	Active	EXTENSION	Elsa Reclamation & Development Company Ltd. - 100%	1925/07/29	1925/08/31	2025/03/30	\$210	21
16087	NM00799	Active	EXTENSION	Elsa Reclamation & Development Company Ltd. - 100%	1925/10/19	1925/11/24	2038/12/15	\$210	21
62944	NM00474	Active	FAIR FRACTION	Elsa Reclamation & Development Company Ltd. - 100%	1955/12/30	1956/01/06	2025/11/26	\$210	21
61725	NM00525	Active	FALLOT	Elsa Reclamation & Development Company Ltd. - 100%	1951/07/09	1951/07/16	2026/11/01	\$210	21
59437	NM00510	Active	FALLS 1	Elsa Reclamation & Development Company Ltd. - 100%	1949/08/16	1949/08/19	2026/11/01	\$210	21
59446	NM00519	Active	FALLS 10	Elsa Reclamation & Development Company Ltd. - 100%	1949/08/16	1949/08/19	2026/11/01	\$210	21
59447	NM00520	Active	FALLS 11	Elsa Reclamation & Development Company Ltd. - 100%	1949/08/17	1949/08/19	2026/11/01	\$210	21
59448	NM00521	Active	FALLS 12	Elsa Reclamation & Development Company Ltd. - 100%	1949/08/17	1949/08/19	2026/11/01	\$210	21
59449	NM00522	Active	FALLS 13	Elsa Reclamation & Development Company Ltd. - 100%	1949/08/17	1949/08/19	2026/11/01	\$210	21
59450	NM00523	Active	FALLS 14	Elsa Reclamation & Development Company Ltd. - 100%	1949/08/17	1949/08/19	2026/11/01	\$210	21
59451	NM00524	Active	FALLS 15	Elsa Reclamation & Development Company Ltd. - 100%	1949/08/17	1949/08/19	2026/11/01	\$210	21
59452	NM00384	Active	FALLS 16	Elsa Reclamation & Development Company Ltd. - 100%	1949/08/16	1949/08/19	2025/05/22	\$210	21
59438	NM00511	Active	FALLS 2	Elsa Reclamation & Development Company Ltd. - 100%	1949/08/16	1949/08/19	2026/11/01	\$210	21
59439	NM00512	Active	FALLS 3	Elsa Reclamation & Development Company Ltd. - 100%	1949/08/16	1949/08/19	2026/11/01	\$210	21
59440	NM00513	Active	FALLS 4	Elsa Reclamation & Development Company Ltd. - 100%	1949/08/16	1949/08/19	2026/11/01	\$210	21
59441	NM00514	Active	FALLS 5	Elsa Reclamation & Development Company Ltd. - 100%	1949/08/16	1949/08/19	2026/11/01	\$210	21
59442	NM00515	Active	FALLS 6	Elsa Reclamation & Development Company Ltd. - 100%	1949/08/16	1949/08/19	2026/11/01	\$210	21
59443	NM00516	Active	FALLS 7	Elsa Reclamation & Development Company Ltd. - 100%	1949/08/16	1949/08/19	2026/11/01	\$210	21
59444	NM00517	Active	FALLS 8	Elsa Reclamation & Development Company Ltd. - 100%	1949/08/16	1949/08/19	2026/11/01	\$210	21
59445	NM00518	Active	FALLS 9	Elsa Reclamation & Development Company Ltd. - 100%	1949/08/16	1949/08/19	2026/11/01	\$210	21
14085	NM00694	Active	FIG TREE	Elsa Reclamation & Development Company Ltd. - 100%	1921/05/03	1921/07/25	2036/01/08	\$210	21
80347	NM00578	Active	FILL	Elsa Reclamation & Development Company Ltd. - 100%	1959/06/03	1959/06/10	2027/11/02	\$210	21
62826	NM00289	Active	FILTER FRACTION	Elsa Reclamation & Development Company Ltd. - 100%	1955/06/16	1955/06/23	2024/06/27	\$210	21
80359	NM00581	Active	FINAL	Elsa Reclamation & Development Company Ltd. - 100%	1959/07/09	1959/07/21	2027/11/02	\$210	21
12876	NM00850	Active	FISHER	Elsa Reclamation & Development Company Ltd. - 100%	1919/09/02	1919/11/26	2040/09/14	\$210	21

Grant	Lease	Status	Claim Name	Owner	Staked	Recorded	Expiry	Renewal Cost per Term (CAD)	Term (Years)
38643	NM00762	Active	FLAME	Elsa Reclamation & Development Company Ltd. - 100%	1929/10/13	1929/11/13	2037/11/29	\$210	21
55527	NM00377	Active	FLY FRACTION	Elsa Reclamation & Development Company Ltd. - 100%	1946/09/18	1947/02/04	2025/05/22	\$210	21
12870	NM00812	Active	FORAKER FRACTIO	Elsa Reclamation & Development Company Ltd. - 100%	1919/10/01	1919/11/13	2038/12/27	\$210	21
13412		Active	FOREST	Elsa Reclamation & Development Company Ltd. - 100%	1920/07/24	1920/09/24	2027/12/31	\$525	5
12845	NM00891	Active	FOX	Elsa Reclamation & Development Company Ltd. - 100%	1919/09/04	1919/10/28	2042/03/11	\$210	21
55599	NM00261	Active	FRANCES 3	Elsa Reclamation & Development Company Ltd. - 100%	1947/03/29	1947/04/18	2029/01/09	\$210	21
55600	NM00262	Active	FRANCES 4	Elsa Reclamation & Development Company Ltd. - 100%	1947/03/29	1947/04/18	2029/01/09	\$210	21
56401	NM00263	Active	FRANCES 5	Elsa Reclamation & Development Company Ltd. - 100%	1947/03/29	1947/04/18	2029/01/09	\$210	21
56402	NM00264	Active	FRANCES 6	Elsa Reclamation & Development Company Ltd. - 100%	1947/03/29	1947/04/18	2029/01/09	\$210	21
56403	NM00265	Active	FRANCES 7	Elsa Reclamation & Development Company Ltd. - 100%	1947/03/29	1947/04/18	2029/01/09	\$210	21
56404	NM00266	Active	FRANCES 8	Elsa Reclamation & Development Company Ltd. - 100%	1947/03/29	1947/04/18	2029/01/09	\$210	21
14220	NM00926	Active	FRANK	Elsa Reclamation & Development Company Ltd. - 100%	1921/07/17	1921/09/24	2042/08/08	\$210	21
13152	NM00685	Active	FRIENDSHIP	Elsa Reclamation & Development Company Ltd. - 100%	1920/05/07	1920/06/16	2035/01/30	\$210	21
55317	NM00963	Active	FROG	Elsa Reclamation & Development Company Ltd. - 100%	1944/10/11	1945/02/19	2043/02/03	\$210	21
59125	NM00871	Active	FRONTIER	Elsa Reclamation & Development Company Ltd. - 100%	1948/11/11	1948/11/13	2040/01/06	\$210	21
80517	NM00584	Active	GAIL FRACTION	Elsa Reclamation & Development Company Ltd. - 100%	1960/07/19	1960/08/04	2027/11/02	\$210	21
Y 69403		Active	Galaxy	Elsa Reclamation & Development Company Ltd. - 100%	1973/05/22	1973/06/05	2026/12/31	\$525	5
YA77506		Active	Galena	Elsa Reclamation & Development Company Ltd. - 100%	1984/06/06	1984/06/13	2028/12/31	\$525	5
13032	NM01012	Active	GALENA FARM	Elsa Reclamation & Development Company Ltd. - 100%	1920/03/04	1920/05/06	2044/03/23	\$210	21
38812	NM00682	Active	GALENA HILL	Elsa Reclamation & Development Company Ltd. - 100%	1934/10/03	1934/11/12	2035/04/14	\$210	21
14816	NM00951	Active	GIBRALTAR	Elsa Reclamation & Development Company Ltd. - 100%	1923/02/28	1923/04/13	2042/08/26	\$210	21
84616	NM00791	Active	GLORIA FRACTION	Elsa Reclamation & Development Company Ltd. - 100%	1965/08/06	1965/08/24	2038/10/17	\$210	21
80361	NM00583	Active	GNAT	Elsa Reclamation & Development Company Ltd. - 100%	1959/07/15	1959/07/22	2027/11/02	\$210	21
55386	NM00886	Active	GOPHER	Elsa Reclamation & Development Company Ltd. - 100%	1945/08/09	1945/10/26	2041/11/14	\$210	21
59821	NM00460	Active	GRACE	Elsa Reclamation & Development Company Ltd. - 100%	1950/10/01	1950/10/02	2025/11/26	\$210	21
15304	NM00767	Active	GREEN BACK	Elsa Reclamation & Development Company Ltd. - 100%	1928/10/04	1928/11/27	2038/03/13	\$210	21
14336	NM00649	Active	GREENSTONE	Elsa Reclamation & Development Company Ltd. - 100%	1921/08/24	1921/10/19	2030/05/28	\$210	21
12817	NM00273	Active	GROUND HOG	Elsa Reclamation & Development Company Ltd. - 100%	1919/09/04	1919/10/20	2029/04/18	\$210	21
15305	NM00940	Active	GRUB STAKE	Elsa Reclamation & Development Company Ltd. - 100%	1928/10/10	1928/11/27	2042/08/20	\$210	21

Grant	Lease	Status	Claim Name	Owner	Staked	Recorded	Expiry	Renewal Cost per Term (CAD)	Term (Years)
80357	NM00579	Active	HAP	Elsa Reclamation & Development Company Ltd. - 100%	1959/07/09	1959/07/21	2027/11/02	\$210	21
10269	NM00833	Active	HAPPY	Elsa Reclamation & Development Company Ltd. - 100%	1936/07/05	1936/07/22	2040/07/27	\$210	21
59315	NM00945	Active	HARDIX	Elsa Reclamation & Development Company Ltd. - 100%	1949/06/25	1949/07/13	2042/08/20	\$210	21
55177	NM00364	Active	HARDWICK	Elsa Reclamation & Development Company Ltd. - 100%	1940/10/08	1940/12/19	2025/04/30	\$210	21
56525	NM00353	Active	HARRIETT	Elsa Reclamation & Development Company Ltd. - 100%	1948/06/12	1948/06/14	2025/03/30	\$210	21
59030	NM00969	Active	HAVLOCK	Elsa Reclamation & Development Company Ltd. - 100%	1948/09/13	1948/09/17	2043/05/07	\$210	21
16025	NM00668	Active	HAWKS NEST	Elsa Reclamation & Development Company Ltd. - 100%	1925/07/28	1925/08/31	2033/11/24	\$210	21
55428	NM00890	Active	HAY	Elsa Reclamation & Development Company Ltd. - 100%	1946/06/02	1946/08/19	2041/11/14	\$210	21
55582	NM00565	Active	HECLA	Elsa Reclamation & Development Company Ltd. - 100%	1946/10/24	1947/03/20	2027/11/02	\$210	21
16326	NM00663	Active	HECTOR	Elsa Reclamation & Development Company Ltd. - 100%	1927/05/09	1927/05/30	2033/06/17	\$210	21
14908	NM00425	Active	HELEN	Elsa Reclamation & Development Company Ltd. - 100%	1923/11/01	1923/11/27	2025/11/26	\$210	21
55364	NM00795	Active	HELEN	Elsa Reclamation & Development Company Ltd. - 100%	1945/07/08	1945/10/25	2038/11/01	\$210	21
55318	NM00429	Active	HENRY	Elsa Reclamation & Development Company Ltd. - 100%	1944/10/11	1945/02/19	2025/11/26	\$210	21
55478	NM00810	Active	HESPERIDES	Elsa Reclamation & Development Company Ltd. - 100%	1946/08/31	1947/01/24	2038/12/15	\$210	21
13072	NM00862	Active	HIGHLANDER	Elsa Reclamation & Development Company Ltd. - 100%	1920/04/03	1920/06/04	2041/04/25	\$210	21
56506	NM00758	Active	HILL	Elsa Reclamation & Development Company Ltd. - 100%	1947/11/21	1947/11/28	2037/05/23	\$210	21
38720	NM00248	Active	HOBO	Elsa Reclamation & Development Company Ltd. - 100%	1931/07/04	1931/07/24	2029/02/28	\$210	21
56577	NM00919	Active	HOBO	Elsa Reclamation & Development Company Ltd. - 100%	1948/07/19	1948/08/03	2042/07/24	\$210	21
61209	NM00387	Active	HOBO 3	Elsa Reclamation & Development Company Ltd. - 100%	1950/12/04	1950/12/18	2025/05/22	\$210	21
56592	NM00225	Active	HOLIDAY 1	Elsa Reclamation & Development Company Ltd. - 100%	1948/08/15	1948/08/23	2028/08/22	\$210	21
56600	NM00232	Active	HOLIDAY 10	Elsa Reclamation & Development Company Ltd. - 100%	1948/08/14	1948/08/23	2028/08/22	\$210	21
59001	NM00233	Active	HOLIDAY 11	Elsa Reclamation & Development Company Ltd. - 100%	1948/08/14	1948/08/23	2028/08/22	\$210	21
59002	NM00234	Active	HOLIDAY 12	Elsa Reclamation & Development Company Ltd. - 100%	1948/08/14	1948/08/23	2028/08/22	\$210	21
59003	NM00235	Active	HOLIDAY 13	Elsa Reclamation & Development Company Ltd. - 100%	1948/08/14	1948/08/23	2028/08/22	\$210	21
59004	NM00236	Active	HOLIDAY 14	Elsa Reclamation & Development Company Ltd. - 100%	1948/08/14	1948/08/23	2028/08/22	\$210	21
56593	NM00226	Active	HOLIDAY 2	Elsa Reclamation & Development Company Ltd. - 100%	1948/08/15	1948/08/23	2028/08/22	\$210	21
56594	NM00227	Active	HOLIDAY 3	Elsa Reclamation & Development Company Ltd. - 100%	1948/08/12	1948/08/23	2028/08/22	\$210	21
56595	NM00228	Active	HOLIDAY 4	Elsa Reclamation & Development Company Ltd. - 100%	1948/08/12	1948/08/23	2028/08/22	\$210	21
56597	NM00229	Active	HOLIDAY 7	Elsa Reclamation & Development Company Ltd. - 100%	1948/08/12	1948/08/23	2028/08/22	\$210	21

Grant	Lease	Status	Claim Name	Owner	Staked	Recorded	Expiry	Renewal Cost per Term (CAD)	Term (Years)
56598	NM00230	Active	HOLIDAY 8	Elsa Reclamation & Development Company Ltd. - 100%	1948/08/12	1948/08/23	2028/08/22	\$210	21
56599	NM00231	Active	HOLIDAY 9	Elsa Reclamation & Development Company Ltd. - 100%	1948/08/14	1948/08/23	2028/08/22	\$210	21
13133	NM00702	Active	HOMESTAKE	Elsa Reclamation & Development Company Ltd. - 100%	1920/04/29	1920/06/15	2036/02/27	\$210	21
59171	NM00279	Active	HONEYMOON 1	Elsa Reclamation & Development Company Ltd. - 100%	1949/01/16	1949/01/25	2029/04/18	\$210	21
59172	NM00379	Active	HONEYMOON 2	Elsa Reclamation & Development Company Ltd. - 100%	1949/01/16	1949/01/25	2025/05/22	\$210	21
59173	NM00380	Active	HONEYMOON 3	Elsa Reclamation & Development Company Ltd. - 100%	1949/01/16	1949/01/25	2025/05/22	\$210	21
59174	NM00381	Active	HONEYMOON 4	Elsa Reclamation & Development Company Ltd. - 100%	1949/01/16	1949/01/25	2025/05/22	\$210	21
59175	NM00382	Active	HONEYMOON 5	Elsa Reclamation & Development Company Ltd. - 100%	1949/01/16	1949/01/25	2025/05/22	\$210	21
59176	NM00383	Active	HONEYMOON 6	Elsa Reclamation & Development Company Ltd. - 100%	1949/01/16	1949/01/25	2025/05/22	\$210	21
55377	NM00366	Active	HOPE	Elsa Reclamation & Development Company Ltd. - 100%	1945/08/04	1945/10/26	2025/04/30	\$210	21
55273	NM00298	Active	HUB	Elsa Reclamation & Development Company Ltd. - 100%	1943/10/21	1944/05/27	2025/01/30	\$210	21
55536	NM00212	Active	HUSKY	Elsa Reclamation & Development Company Ltd. - 100%	1946/10/15	1947/02/12	2028/08/10	\$210	21
55537	NM00213	Active	HUSKY 1	Elsa Reclamation & Development Company Ltd. - 100%	1946/10/15	1947/02/12	2028/08/10	\$210	21
56576	NM00224	Active	HUSKY 12	Elsa Reclamation & Development Company Ltd. - 100%	1948/07/19	1948/07/21	2028/08/10	\$210	21
55538	NM00214	Active	HUSKY 2	Elsa Reclamation & Development Company Ltd. - 100%	1946/10/15	1947/02/12	2028/08/10	\$210	21
55539	NM00215	Active	HUSKY 3	Elsa Reclamation & Development Company Ltd. - 100%	1946/10/15	1946/10/22	2028/08/10	\$210	21
55540	NM00216	Active	HUSKY 4	Elsa Reclamation & Development Company Ltd. - 100%	1946/10/15	1946/10/22	2028/08/10	\$210	21
55541	NM00217	Active	HUSKY 5	Elsa Reclamation & Development Company Ltd. - 100%	1946/10/15	1946/10/22	2028/08/10	\$210	21
55542	NM00218	Active	HUSKY 6	Elsa Reclamation & Development Company Ltd. - 100%	1946/10/15	1946/10/22	2028/08/10	\$210	21
55543	NM00219	Active	HUSKY 7	Elsa Reclamation & Development Company Ltd. - 100%	1946/10/15	1946/10/22	2028/08/10	\$210	21
55544	NM00220	Active	HUSKY 8	Elsa Reclamation & Development Company Ltd. - 100%	1946/10/15	1947/02/12	2028/08/10	\$210	21
55545	NM00221	Active	HUSKY 9	Elsa Reclamation & Development Company Ltd. - 100%	1946/10/15	1946/10/22	2028/08/10	\$210	21
14087	NM00696	Active	HUXLEY	Elsa Reclamation & Development Company Ltd. - 100%	1921/05/03	1921/07/26	2036/01/20	\$210	21
55479	NM00602	Active	IDOL	Elsa Reclamation & Development Company Ltd. - 100%	1946/08/26	1947/01/24	2029/07/22	\$210	21
16554	NM00247	Active	IKWOGGY	Elsa Reclamation & Development Company Ltd. - 100%	1925/05/29	1925/06/15	2029/02/28	\$210	21
59385	NM00272	Active	INCA	Elsa Reclamation & Development Company Ltd. - 100%	1949/07/23	1949/07/29	2029/01/18	\$210	21
80346	NM00577	Active	INCA FRACTION	Elsa Reclamation & Development Company Ltd. - 100%	1959/04/23	1959/04/30	2027/11/02	\$210	21
56567	NM00985	Active	INDIANA	Elsa Reclamation & Development Company Ltd. - 100%	1948/06/26	1948/06/28	2043/06/12	\$210	21
55326	NM00373	Active	IRENE	Elsa Reclamation & Development Company Ltd. - 100%	1945/04/06	1945/10/16	2025/05/22	\$210	21

Grant	Lease	Status	Claim Name	Owner	Staked	Recorded	Expiry	Renewal Cost per Term (CAD)	Term (Years)
13799		Active	IVAN	Elsa Reclamation & Development Company Ltd. - 100%	1921/05/12	1921/06/23	2027/12/31	\$525	5
12810	NM00394	Active	IVY	Elsa Reclamation & Development Company Ltd. - 100%	1919/08/23	1919/10/14	2025/06/12	\$210	21
61744	NM00398	Active	JACK	Elsa Reclamation & Development Company Ltd. - 100%	1951/07/14	1951/07/20	2025/06/12	\$210	21
55427	NM00889	Active	JAY	Elsa Reclamation & Development Company Ltd. - 100%	1946/06/01	1946/08/19	2041/11/14	\$210	21
12809	NM00393	Active	JEAN	Elsa Reclamation & Development Company Ltd. - 100%	1919/08/23	1919/10/10	2025/06/12	\$210	21
16524	NM00774	Active	JEAN	Elsa Reclamation & Development Company Ltd. - 100%	1924/09/12	1924/10/11	2038/05/19	\$210	21
84626	NM00793	Active	JEAN FRACTIONAL	Elsa Reclamation & Development Company Ltd. - 100%	1965/08/20	1965/08/26	2038/10/17	\$210	21
15294	NM00999	Active	JEFFREY SPECIAL	Elsa Reclamation & Development Company Ltd. - 100%	1928/09/06	1928/09/28	2044/02/02	\$210	21
81139	NM00587	Active	JEFFY FRACTION	Elsa Reclamation & Development Company Ltd. - 100%	1962/05/29	1962/05/31	2027/11/02	\$210	21
55581	NM00965	Active	JENBET	Elsa Reclamation & Development Company Ltd. - 100%	1946/10/24	1947/03/20	2043/02/03	\$210	21
83532	NM00624	Active	JENNY 3	Elsa Reclamation & Development Company Ltd. - 100%	1964/07/15	1964/07/17	2030/02/28	\$210	21
81228	NM00588	Active	JENNY FRACTION	Elsa Reclamation & Development Company Ltd. - 100%	1962/06/13	1962/06/28	2027/11/02	\$210	21
83003	NM00590	Active	JENNY TOO FRACT	Elsa Reclamation & Development Company Ltd. - 100%	1963/06/05	1963/06/12	2027/11/02	\$210	21
38694	NM00679	Active	JESSIE	Elsa Reclamation & Development Company Ltd. - 100%	1930/10/26	1930/11/21	2035/04/14	\$210	21
59178	NM00237	Active	JESSIE 1	Elsa Reclamation & Development Company Ltd. - 100%	1949/01/20	1949/01/25	2028/08/29	\$210	21
59180	NM00238	Active	JESSIE 3	Elsa Reclamation & Development Company Ltd. - 100%	1949/01/20	1949/01/25	2028/08/29	\$210	21
38744	NM00681	Active	JEWEL	Elsa Reclamation & Development Company Ltd. - 100%	1932/06/20	1932/07/21	2035/04/14	\$210	21
15366	NM00837	Active	JIGGYWIG	Elsa Reclamation & Development Company Ltd. - 100%	1929/06/09	1929/07/18	2040/07/27	\$210	21
55330	NM00883	Active	JIMMIE	Elsa Reclamation & Development Company Ltd. - 100%	1945/05/01	1945/10/16	2041/11/14	\$210	21
38715	NM00664	Active	JOCK	Elsa Reclamation & Development Company Ltd. - 100%	1931/05/03	1931/05/20	2033/06/17	\$210	21
61919	NM00399	Active	JOY FRACTION	Elsa Reclamation & Development Company Ltd. - 100%	1951/08/30	1951/08/31	2025/06/12	\$210	21
82531	NM00655	Active	Joyce	Elsa Reclamation & Development Company Ltd. - 100%	1963/03/05	1963/03/12	2031/03/12	\$210	21
14880	NM00952	Active	JUMBO	Elsa Reclamation & Development Company Ltd. - 100%	1923/09/29	1923/10/17	2042/08/26	\$210	21
62992	NM00614	Active	JUNE	Elsa Reclamation & Development Company Ltd. - 100%	1956/06/24	1956/07/11	2029/08/21	\$210	21
59274	NM00796	Active	JUNE	Elsa Reclamation & Development Company Ltd. - 100%	1949/06/12	1949/06/22	2038/11/01	\$210	21
80345		Active	K.P.O.	Elsa Reclamation & Development Company Ltd. - 100%	1958/10/07	1958/10/14	2043/12/31	\$525	5
80082		Active	K.P.O. 1	Elsa Reclamation & Development Company Ltd. - 100%	1956/10/05	1956/10/05	2043/12/31	\$525	5
80362		Active	K.P.O. 13	Elsa Reclamation & Development Company Ltd. - 100%	1959/07/15	1959/07/24	2043/12/31	\$525	5
80364		Active	K.P.O. 15	Elsa Reclamation & Development Company Ltd. - 100%	1959/07/15	1959/07/24	2043/12/31	\$525	5

Grant	Lease	Status	Claim Name	Owner	Staked	Recorded	Expiry	Renewal Cost per Term (CAD)	Term (Years)
80366		Active	K.P.O. 17	Elsa Reclamation & Development Company Ltd. - 100%	1959/07/15	1959/07/24	2043/12/31	\$525	5
80367		Active	K.P.O. 18	Elsa Reclamation & Development Company Ltd. - 100%	1959/07/15	1959/07/24	2043/12/31	\$525	5
80368		Active	K.P.O. 19	Elsa Reclamation & Development Company Ltd. - 100%	1959/07/15	1959/07/24	2043/12/31	\$525	5
80083		Active	K.P.O. 2	Elsa Reclamation & Development Company Ltd. - 100%	1956/10/05	1956/10/05	2043/12/31	\$525	5
80369		Active	K.P.O. 20	Elsa Reclamation & Development Company Ltd. - 100%	1959/07/15	1959/07/24	2043/12/31	\$525	5
80370		Active	K.P.O. 21	Elsa Reclamation & Development Company Ltd. - 100%	1959/07/16	1959/07/24	2043/12/31	\$525	5
80372		Active	K.P.O. 23	Elsa Reclamation & Development Company Ltd. - 100%	1959/07/16	1959/07/24	2043/12/31	\$525	5
80374		Active	K.P.O. 25	Elsa Reclamation & Development Company Ltd. - 100%	1959/07/17	1959/07/24	2043/12/31	\$525	5
80376		Active	K.P.O. 27	Elsa Reclamation & Development Company Ltd. - 100%	1959/07/18	1959/07/24	2043/12/31	\$525	5
80378		Active	K.P.O. 29	Elsa Reclamation & Development Company Ltd. - 100%	1959/07/19	1959/07/28	2043/12/31	\$525	5
80084		Active	K.P.O. 3	Elsa Reclamation & Development Company Ltd. - 100%	1956/10/05	1956/10/05	2043/12/31	\$525	5
80085		Active	K.P.O. 4	Elsa Reclamation & Development Company Ltd. - 100%	1956/10/05	1956/10/05	2043/12/31	\$525	5
80561	NM00586	Active	KANGAROO FRACTI	Elsa Reclamation & Development Company Ltd. - 100%	1960/10/18	1960/10/25	2027/11/02	\$210	21
62248	NM00526	Active	KARIN	Elsa Reclamation & Development Company Ltd. - 100%	1952/09/04	1952/09/05	2026/11/01	\$210	21
62198	NM00401	Active	KARL	Elsa Reclamation & Development Company Ltd. - 100%	1952/07/21	1952/08/04	2025/06/12	\$210	21
59177	NM00286	Active	KAY R.	Elsa Reclamation & Development Company Ltd. - 100%	1949/01/19	1949/01/25	2024/06/27	\$210	21
59336	NM00843	Active	KAYE	Elsa Reclamation & Development Company Ltd. - 100%	1949/07/14	1949/07/19	2040/07/27	\$210	21
55579	NM00278	Active	KENO	Elsa Reclamation & Development Company Ltd. - 100%	1946/09/19	1947/03/20	2029/04/18	\$210	21
12784	NM00622	Active	KENO	Elsa Reclamation & Development Company Ltd. - 100%	1919/07/29	1919/09/10	2030/02/23	\$210	21
16556	NM00768	Active	KENO	Elsa Reclamation & Development Company Ltd. - 100%	1925/05/29	1925/06/18	2038/03/21	\$210	21
55024	NM00830	Active	KENO	Elsa Reclamation & Development Company Ltd. - 100%	1936/10/14	1936/10/30	2039/08/18	\$210	21
62295	NM00468	Active	KENT	Elsa Reclamation & Development Company Ltd. - 100%	1952/10/04	1952/10/11	2025/11/26	\$210	21
62310	NM00469	Active	KID	Elsa Reclamation & Development Company Ltd. - 100%	1953/07/02	1953/07/15	2025/11/26	\$210	21
12812	NM00748	Active	KID	Elsa Reclamation & Development Company Ltd. - 100%	1919/08/17	1919/10/16	2036/10/19	\$210	21
56419	NM00944	Active	KIJO	Elsa Reclamation & Development Company Ltd. - 100%	1947/05/31	1947/06/10	2042/08/20	\$210	21
15264	NM00346	Active	KIM	Elsa Reclamation & Development Company Ltd. - 100%	1928/07/28	1928/08/10	2025/03/30	\$210	21
62270	NM00342	Active	KING	Elsa Reclamation & Development Company Ltd. - 100%	1952/09/13	1952/09/17	2025/02/15	\$210	21
12818	NM00660	Active	KING	Elsa Reclamation & Development Company Ltd. - 100%	1919/09/04	1919/10/20	2031/09/27	\$210	21
15323	NM01000	Active	KLONDIKE	Elsa Reclamation & Development Company Ltd. - 100%	1929/03/07	1929/04/25	2044/02/02	\$210	21

Grant	Lease	Status	Claim Name	Owner	Staked	Recorded	Expiry	Renewal Cost per Term (CAD)	Term (Years)
13558	NM00603	Active	LADUE	Elsa Reclamation & Development Company Ltd. - 100%	1920/09/11	1920/11/05	2029/07/07	\$210	21
13225	NM00645	Active	LAKE 1	Elsa Reclamation & Development Company Ltd. - 100%	1920/06/08	1920/07/13	2030/04/27	\$210	21
13276	NM00646	Active	LAKE 2	Elsa Reclamation & Development Company Ltd. - 100%	1920/06/08	1920/08/25	2030/04/27	\$210	21
13277	NM00647	Active	LAKE 3	Elsa Reclamation & Development Company Ltd. - 100%	1920/06/08	1920/08/25	2030/04/27	\$210	21
13222	NM00635	Active	LAKOTA	Elsa Reclamation & Development Company Ltd. - 100%	1920/06/07	1920/07/09	2029/12/31	\$210	21
62051	NM00400	Active	LAMB FRACTION	Elsa Reclamation & Development Company Ltd. - 100%	1951/10/26	1951/11/07	2025/06/12	\$210	21
12961	NM00857	Active	LAST CHANCE	Elsa Reclamation & Development Company Ltd. - 100%	1919/09/06	1920/02/26	2041/02/05	\$210	21
62977	NM00650	Active	LE BLANC	Elsa Reclamation & Development Company Ltd. - 100%	1956/06/10	1956/06/21	2031/03/12	\$210	21
61635		Active	LEO	Elsa Reclamation & Development Company Ltd. - 100%	1951/06/10	1951/06/11	2043/12/31	\$525	5
59710		Active	LEO 1	Elsa Reclamation & Development Company Ltd. - 100%	1950/09/23	1950/09/26	2043/12/31	\$525	5
59850		Active	LEO 10	Elsa Reclamation & Development Company Ltd. - 100%	1950/09/27	1950/10/02	2043/12/31	\$525	5
59851		Active	LEO 11	Elsa Reclamation & Development Company Ltd. - 100%	1950/09/27	1950/10/02	2043/12/31	\$525	5
59852		Active	LEO 12	Elsa Reclamation & Development Company Ltd. - 100%	1950/09/27	1950/10/02	2043/12/31	\$525	5
59853		Active	LEO 13	Elsa Reclamation & Development Company Ltd. - 100%	1950/09/27	1950/10/02	2043/12/31	\$525	5
59854		Active	LEO 14	Elsa Reclamation & Development Company Ltd. - 100%	1950/09/27	1950/10/02	2043/12/31	\$525	5
59855		Active	LEO 15	Elsa Reclamation & Development Company Ltd. - 100%	1950/09/27	1950/10/02	2043/12/31	\$525	5
59856		Active	LEO 16	Elsa Reclamation & Development Company Ltd. - 100%	1950/09/27	1950/10/02	2043/12/31	\$525	5
59857		Active	LEO 17	Elsa Reclamation & Development Company Ltd. - 100%	1950/09/27	1950/10/02	2043/12/31	\$525	5
59941		Active	LEO 18	Elsa Reclamation & Development Company Ltd. - 100%	1950/10/09	1950/10/12	2043/12/31	\$525	5
59942		Active	LEO 19	Elsa Reclamation & Development Company Ltd. - 100%	1950/10/09	1950/10/12	2043/12/31	\$525	5
59711		Active	LEO 2	Elsa Reclamation & Development Company Ltd. - 100%	1950/09/23	1950/09/26	2043/12/31	\$525	5
59712		Active	LEO 3	Elsa Reclamation & Development Company Ltd. - 100%	1950/09/23	1950/09/26	2043/12/31	\$525	5
59714		Active	LEO 4	Elsa Reclamation & Development Company Ltd. - 100%	1950/09/23	1950/09/26	2043/12/31	\$525	5
59715		Active	LEO 5	Elsa Reclamation & Development Company Ltd. - 100%	1950/09/23	1950/09/26	2043/12/31	\$525	5
59716		Active	LEO 6	Elsa Reclamation & Development Company Ltd. - 100%	1950/09/23	1950/09/26	2043/12/31	\$525	5
59717		Active	LEO 7	Elsa Reclamation & Development Company Ltd. - 100%	1950/09/23	1950/09/26	2043/12/31	\$525	5
59718		Active	LEO 8	Elsa Reclamation & Development Company Ltd. - 100%	1950/09/23	1950/09/26	2043/12/31	\$525	5
59849		Active	LEO 9	Elsa Reclamation & Development Company Ltd. - 100%	1950/09/27	1950/10/02	2043/12/31	\$525	5
16512	NM00671	Active	LILL	Elsa Reclamation & Development Company Ltd. - 100%	1924/08/14	1924/09/09	2033/11/24	\$210	21

Grant	Lease	Status	Claim Name	Owner	Staked	Recorded	Expiry	Renewal Cost per Term (CAD)	Term (Years)
14222	NM00501	Active	LILY	Elsa Reclamation & Development Company Ltd. - 100%	1921/07/17	1921/09/24	2026/03/31	\$210	21
55442	NM00284	Active	LIME	Elsa Reclamation & Development Company Ltd. - 100%	1946/07/21	1946/07/30	2024/06/27	\$210	21
15364	NM00769	Active	LINK	Elsa Reclamation & Development Company Ltd. - 100%	1929/06/07	1929/07/16	2038/03/22	\$210	21
12830	NM00750	Active	LION	Elsa Reclamation & Development Company Ltd. - 100%	1919/08/27	1919/10/23	2036/10/24	\$210	21
82289	NM00589	Active	LITE FRACTION	Elsa Reclamation & Development Company Ltd. - 100%	1962/08/01	1962/08/07	2027/11/02	\$210	21
14229	NM00928	Active	LITTLE CHARLIE	Elsa Reclamation & Development Company Ltd. - 100%	1921/08/18	1921/09/24	2042/08/08	\$210	21
15329	NM00766	Active	LITTLE FRACTION	Elsa Reclamation & Development Company Ltd. - 100%	1929/04/07	1929/05/16	2038/03/08	\$210	21
55269	NM00881	Active	LITTLE GIRL	Elsa Reclamation & Development Company Ltd. - 100%	1943/06/28	1943/11/09	2041/11/14	\$210	21
12821	NM00423	Active	LIZZIE	Elsa Reclamation & Development Company Ltd. - 100%	1919/09/07	1919/10/20	2025/11/26	\$210	21
12965	NM00859	Active	LONE STAR	Elsa Reclamation & Development Company Ltd. - 100%	1919/09/02	1920/03/01	2041/02/20	\$210	21
59673	NM00396	Active	LOON	Elsa Reclamation & Development Company Ltd. - 100%	1950/09/07	1950/09/08	2025/06/12	\$210	21
56516	NM00321	Active	LOOS	Elsa Reclamation & Development Company Ltd. - 100%	1948/04/18	1948/04/21	2025/02/02	\$210	21
55495	NM00851	Active	LORNE	Elsa Reclamation & Development Company Ltd. - 100%	1946/09/14	1947/02/01	2040/10/12	\$210	21
13019	NM00625	Active	LOTUS	Elsa Reclamation & Development Company Ltd. - 100%	1920/02/22	1920/05/04	2029/11/25	\$210	21
56405	NM00433	Active	LOUIS 1	Elsa Reclamation & Development Company Ltd. - 100%	1947/03/29	1947/04/18	2025/11/26	\$210	21
56406	NM00596	Active	LOUIS 2	Elsa Reclamation & Development Company Ltd. - 100%	1947/03/22	1947/04/18	2027/11/26	\$210	21
56407	NM00434	Active	LOUIS 3	Elsa Reclamation & Development Company Ltd. - 100%	1947/03/22	1947/04/18	2025/11/26	\$210	21
56408	NM00435	Active	LOUIS 4	Elsa Reclamation & Development Company Ltd. - 100%	1947/03/22	1947/04/18	2025/11/26	\$210	21
14219	NM00925	Active	LOUISE	Elsa Reclamation & Development Company Ltd. - 100%	1921/07/17	1921/09/24	2042/08/08	\$210	21
55501	NM00300	Active	LOVIE	Elsa Reclamation & Development Company Ltd. - 100%	1946/09/15	1947/02/01	2025/01/30	\$210	21
16585	NM00771	Active	LUCKY	Elsa Reclamation & Development Company Ltd. - 100%	1925/06/09	1925/06/11	2038/03/29	\$210	21
13021	NM00674	Active	LUCKY QUEEN	Elsa Reclamation & Development Company Ltd. - 100%	1920/02/18	1920/05/04	2035/02/17	\$210	21
16552	NM00775	Active	LUCKY STRIKE	Elsa Reclamation & Development Company Ltd. - 100%	1925/05/22	1925/06/15	2038/06/14	\$210	21
13586	NM00637	Active	LUNA	Elsa Reclamation & Development Company Ltd. - 100%	1920/09/09	1920/11/12	2029/12/31	\$210	21
38857	NM00632	Active	M.T.	Elsa Reclamation & Development Company Ltd. - 100%	1935/08/22	1935/10/01	2029/12/06	\$210	21
2201	NM00816	Active	MABEL	Elsa Reclamation & Development Company Ltd. - 100%	1913/02/23	1913/03/17	2039/02/15	\$210	21
62202	NM00464	Active	MAGGIE	Elsa Reclamation & Development Company Ltd. - 100%	1952/07/31	1952/08/05	2025/11/26	\$210	21
14233	NM00659	Active	MAGGIE	Elsa Reclamation & Development Company Ltd. - 100%	1921/06/28	1921/09/24	2031/09/24	\$210	21
12829	NM00747	Active	MAPLE LEAF	Elsa Reclamation & Development Company Ltd. - 100%	1919/08/27	1919/10/23	2036/10/15	\$210	21

Grant	Lease	Status	Claim Name	Owner	Staked	Recorded	Expiry	Renewal Cost per Term (CAD)	Term (Years)
59520	NM00385	Active	MARG	Elsa Reclamation & Development Company Ltd. - 100%	1949/12/10	1949/12/14	2025/05/22	\$210	21
56530	NM00508	Active	MARIE ELENA	Elsa Reclamation & Development Company Ltd. - 100%	1948/06/11	1948/06/17	2026/11/01	\$210	21
55385	NM00885	Active	MARMOT	Elsa Reclamation & Development Company Ltd. - 100%	1945/08/09	1945/10/26	2041/11/14	\$210	21
13787	NM00618	Active	MARY	Elsa Reclamation & Development Company Ltd. - 100%	1921/05/09	1921/06/21	2030/01/31	\$210	21
59014	NM00968	Active	MARY L.	Elsa Reclamation & Development Company Ltd. - 100%	1948/08/28	1948/09/01	2043/05/07	\$210	21
14168	NM00690	Active	MASTIFF	Elsa Reclamation & Development Company Ltd. - 100%	1921/07/10	1921/09/14	2035/11/14	\$210	21
12937	NM00764	Active	MATHOLE	Elsa Reclamation & Development Company Ltd. - 100%	1919/10/12	1920/01/03	2037/09/07	\$210	21
59255	NM00271	Active	MATTAGAMI	Elsa Reclamation & Development Company Ltd. - 100%	1949/06/01	1949/06/03	2029/01/18	\$210	21
38748	NM00759	Active	MAY	Elsa Reclamation & Development Company Ltd. - 100%	1932/07/25	1932/08/15	2037/09/03	\$210	21
56573	NM00438	Active	MAYO	Elsa Reclamation & Development Company Ltd. - 100%	1948/06/22	1948/07/12	2025/11/26	\$210	21
12919	NM00752	Active	MAYO	Elsa Reclamation & Development Company Ltd. - 100%	1919/09/09	1919/12/22	2036/12/21	\$210	21
55497	NM00852	Active	MAYO	Elsa Reclamation & Development Company Ltd. - 100%	1946/09/12	1947/02/01	2040/10/12	\$210	21
38619	NM00815	Active	McCARTHY FRACTI	Elsa Reclamation & Development Company Ltd. - 100%	1929/08/15	1929/09/19	2039/01/01	\$210	21
62131	NM00848	Active	METEOR	Elsa Reclamation & Development Company Ltd. - 100%	1952/06/15	1952/06/16	2040/07/27	\$210	21
14088	NM00693	Active	MIDWAY	Elsa Reclamation & Development Company Ltd. - 100%	1921/05/03	1921/07/26	2035/12/30	\$210	21
56590	NM00568	Active	MIKE	Elsa Reclamation & Development Company Ltd. - 100%	1948/08/12	1948/08/18	2027/11/02	\$210	21
59764	NM00571	Active	MIKE	Elsa Reclamation & Development Company Ltd. - 100%	1950/09/21	1950/09/26	2027/11/02	\$210	21
16571	NM00755	Active	MINERVA	Elsa Reclamation & Development Company Ltd. - 100%	1925/05/29	1925/07/07	2037/03/22	\$210	21
16040	NM00756	Active	MINERVA JR.	Elsa Reclamation & Development Company Ltd. - 100%	1925/08/17	1925/09/23	2037/04/14	\$210	21
62837	NM00406	Active	MINK FRACTION	Elsa Reclamation & Development Company Ltd. - 100%	1955/07/26	1955/08/03	2025/06/12	\$210	21
12814	NM00633	Active	MINTO	Elsa Reclamation & Development Company Ltd. - 100%	1919/08/16	1919/08/17	2029/12/16	\$210	21
12920	NM00424	Active	MINTO 2	Elsa Reclamation & Development Company Ltd. - 100%	1919/09/10	1919/12/22	2025/11/26	\$210	21
12879	NM00877	Active	MIRAMICHI	Elsa Reclamation & Development Company Ltd. - 100%	1919/08/30	1919/09/26	2041/09/16	\$210	21
81227	NM00654	Active	Mo	Elsa Reclamation & Development Company Ltd. - 100%	1962/06/20	1962/06/26	2031/03/12	\$210	21
15236	NM00757	Active	MOHAWK	Elsa Reclamation & Development Company Ltd. - 100%	1928/05/16	1928/06/13	2037/04/20	\$210	21
55443	NM00432	Active	MONARCH	Elsa Reclamation & Development Company Ltd. - 100%	1946/07/22	1946/08/26	2025/11/26	\$210	21
16568	NM00672	Active	MONOPLY	Elsa Reclamation & Development Company Ltd. - 100%	1925/05/28	1925/07/07	2033/11/24	\$210	21
16569	NM00673	Active	MONTE CARLO	Elsa Reclamation & Development Company Ltd. - 100%	1925/06/05	1925/07/07	2033/11/24	\$210	21
55312	NM00981	Active	MONTY	Elsa Reclamation & Development Company Ltd. - 100%	1944/07/24	1945/02/13	2043/06/12	\$210	21

Grant	Lease	Status	Claim Name	Owner	Staked	Recorded	Expiry	Renewal Cost per Term (CAD)	Term (Years)
12819	NM00876	Active	MOOSE	Elsa Reclamation & Development Company Ltd. - 100%	1919/09/02	1919/10/20	2041/08/21	\$210	21
62267	NM00339	Active	MORGAN	Elsa Reclamation & Development Company Ltd. - 100%	1952/09/13	1952/09/17	2025/02/15	\$210	21
55332	NM00374	Active	MOSS	Elsa Reclamation & Development Company Ltd. - 100%	1945/05/22	1945/10/16	2025/05/22	\$210	21
62366	NM00358	Active	MOSSBACK	Elsa Reclamation & Development Company Ltd. - 100%	1954/05/30	1954/06/08	2025/03/30	\$210	21
38642	NM00760	Active	MOTH	Elsa Reclamation & Development Company Ltd. - 100%	1929/10/10	1929/11/13	2037/12/08	\$210	21
13025	NM00834	Active	NABOB	Elsa Reclamation & Development Company Ltd. - 100%	1920/03/07	1920/05/05	2040/07/27	\$210	21
14990	NM00359	Active	NAETHING	Elsa Reclamation & Development Company Ltd. - 100%	1924/06/10	1924/07/09	2025/04/12	\$210	21
59341	NM00844	Active	NANCE	Elsa Reclamation & Development Company Ltd. - 100%	1949/07/14	1949/07/19	2040/07/27	\$210	21
15374	NM00427	Active	NANCY	Elsa Reclamation & Development Company Ltd. - 100%	1929/06/21	1929/07/24	2025/11/26	\$210	21
12880	NM00861	Active	NAPOLEON	Elsa Reclamation & Development Company Ltd. - 100%	1919/09/16	1919/11/28	2041/03/13	\$210	21
38873	NM00630	Active	NEIN	Elsa Reclamation & Development Company Ltd. - 100%	1935/10/31	1935/12/04	2029/12/06	\$210	21
59169	NM00443	Active	NEWLYWED 1	Elsa Reclamation & Development Company Ltd. - 100%	1949/01/16	1949/01/25	2025/11/26	\$210	21
59170	NM00444	Active	NEWLYWED 2	Elsa Reclamation & Development Company Ltd. - 100%	1949/01/16	1949/01/25	2025/11/26	\$210	21
55583	NM00566	Active	NIKKA	Elsa Reclamation & Development Company Ltd. - 100%	1946/10/23	1947/03/20	2027/11/02	\$210	21
83004	NM00591	Active	NIP FRACTION	Elsa Reclamation & Development Company Ltd. - 100%	1963/06/10	1963/06/12	2027/11/02	\$210	21
62235	NM00576	Active	NM	Elsa Reclamation & Development Company Ltd. - 100%	1952/08/26	1952/08/27	2027/11/02	\$210	21
16511	NM00670	Active	NO CASH	Elsa Reclamation & Development Company Ltd. - 100%	1924/08/09	1924/09/09	2033/11/24	\$210	21
16170	NM00800	Active	NOD FR.	Elsa Reclamation & Development Company Ltd. - 100%	1926/06/13	1926/07/13	2038/12/15	\$210	21
38658	NM00504	Active	NOIDER	Elsa Reclamation & Development Company Ltd. - 100%	1930/01/07	1930/01/27	2026/11/01	\$210	21
83010	NM00592	Active	NORTH FRACTION	Elsa Reclamation & Development Company Ltd. - 100%	1963/06/24	1963/06/25	2027/11/02	\$210	21
16012	NM00347	Active	NORTH STAR	Elsa Reclamation & Development Company Ltd. - 100%	1925/07/08	1925/08/14	2025/03/30	\$210	21
13415	NM00992	Active	NORTH STAR	Elsa Reclamation & Development Company Ltd. - 100%	1920/07/24	1920/09/25	2043/11/13	\$210	21
80360	NM00582	Active	OBOE	Elsa Reclamation & Development Company Ltd. - 100%	1959/07/15	1959/07/22	2027/11/02	\$210	21
56566	NM00984	Active	OHIO	Elsa Reclamation & Development Company Ltd. - 100%	1948/06/26	1948/06/28	2043/06/12	\$210	21
13094	NM00556	Active	OK FRACTION	Elsa Reclamation & Development Company Ltd. - 100%	1920/04/18	1920/06/09	2027/11/02	\$210	21
61596	NM00461	Active	ONEK	Elsa Reclamation & Development Company Ltd. - 100%	1951/05/15	1951/05/21	2025/11/26	\$210	21
14086	NM00697	Active	ORANGE	Elsa Reclamation & Development Company Ltd. - 100%	1921/05/03	1921/07/25	2036/01/21	\$210	21
62959		Active	ORCHID 10	Elsa Reclamation & Development Company Ltd. - 100%	1956/05/18	1956/05/30	2042/12/31	\$525	5
62960		Active	ORCHID 11	Elsa Reclamation & Development Company Ltd. - 100%	1956/05/18	1956/05/30	2042/12/31	\$525	5

Grant	Lease	Status	Claim Name	Owner	Staked	Recorded	Expiry	Renewal Cost per Term (CAD)	Term (Years)
62961		Active	ORCHID 12	Elsa Reclamation & Development Company Ltd. - 100%	1956/05/18	1956/05/30	2042/12/31	\$525	5
80123	NM00490	Active	ORCHID 13	Elsa Reclamation & Development Company Ltd. - 100%	1956/12/07	1956/12/13	2025/11/26	\$210	21
80124	NM00491	Active	ORCHID 14	Elsa Reclamation & Development Company Ltd. - 100%	1956/12/07	1956/12/13	2025/11/26	\$210	21
62964		Active	ORCHID 17	Elsa Reclamation & Development Company Ltd. - 100%	1956/05/18	1956/05/30	2042/12/31	\$525	5
62966		Active	ORCHID 19	Elsa Reclamation & Development Company Ltd. - 100%	1956/05/18	1956/05/30	2042/12/31	\$525	5
62951		Active	ORCHID 2	Elsa Reclamation & Development Company Ltd. - 100%	1956/05/16	1956/05/30	2042/12/31	\$525	5
62968		Active	ORCHID 21	Elsa Reclamation & Development Company Ltd. - 100%	1956/05/18	1956/05/30	2043/12/31	\$525	5
62969		Active	ORCHID 22	Elsa Reclamation & Development Company Ltd. - 100%	1956/05/18	1956/05/30	2043/12/31	\$525	5
62970		Active	ORCHID 23	Elsa Reclamation & Development Company Ltd. - 100%	1956/05/18	1956/05/30	2043/12/31	\$525	5
62971		Active	ORCHID 24	Elsa Reclamation & Development Company Ltd. - 100%	1956/05/18	1956/05/30	2043/12/31	\$525	5
62975	NM00482	Active	ORCHID 28	Elsa Reclamation & Development Company Ltd. - 100%	1956/05/19	1956/05/30	2025/11/26	\$210	21
62976	NM00483	Active	ORCHID 29	Elsa Reclamation & Development Company Ltd. - 100%	1956/05/19	1956/05/30	2025/11/26	\$210	21
80179	NM00500	Active	ORCHID 30	Elsa Reclamation & Development Company Ltd. - 100%	1957/05/07	1957/05/10	2025/11/26	\$210	21
80120	NM00487	Active	ORCHID 34	Elsa Reclamation & Development Company Ltd. - 100%	1956/12/04	1956/12/13	2025/11/26	\$210	21
80121	NM00488	Active	ORCHID 35	Elsa Reclamation & Development Company Ltd. - 100%	1956/12/07	1956/12/13	2025/11/26	\$210	21
80122	NM00489	Active	ORCHID 36	Elsa Reclamation & Development Company Ltd. - 100%	1956/12/07	1956/12/13	2025/11/26	\$210	21
80164	NM00494	Active	ORCHID 39	Elsa Reclamation & Development Company Ltd. - 100%	1957/03/27	1957/04/03	2025/11/26	\$210	21
62953		Active	ORCHID 4	Elsa Reclamation & Development Company Ltd. - 100%	1956/05/16	1956/05/30	2042/12/31	\$525	5
80165	NM00495	Active	ORCHID 40	Elsa Reclamation & Development Company Ltd. - 100%	1957/03/27	1957/04/03	2025/11/26	\$210	21
80168	NM00498	Active	ORCHID 43	Elsa Reclamation & Development Company Ltd. - 100%	1957/03/27	1957/04/03	2025/11/26	\$210	21
80169		Active	ORCHID 44	Elsa Reclamation & Development Company Ltd. - 100%	1957/03/27	1957/04/03	2043/12/31	\$525	5
80170		Active	ORCHID 45	Elsa Reclamation & Development Company Ltd. - 100%	1957/03/27	1957/04/03	2043/12/31	\$525	5
Y 68364		Active	Orchid 46	Elsa Reclamation & Development Company Ltd. - 100%	1972/07/12	1972/07/19	2043/12/31	\$525	5
Y 68365		Active	Orchid 47	Elsa Reclamation & Development Company Ltd. - 100%	1972/07/12	1972/07/19	2043/12/31	\$525	5
Y 68366		Active	Orchid 48	Elsa Reclamation & Development Company Ltd. - 100%	1972/07/12	1972/07/19	2043/12/31	\$525	5
Y 68367		Active	Orchid 49	Elsa Reclamation & Development Company Ltd. - 100%	1972/07/12	1972/07/19	2043/12/31	\$525	5
Y 68368		Active	Orchid 50	Elsa Reclamation & Development Company Ltd. - 100%	1972/07/12	1972/07/19	2043/12/31	\$525	5
Y 68369		Active	Orchid 51	Elsa Reclamation & Development Company Ltd. - 100%	1972/07/12	1972/07/19	2043/12/31	\$525	5
Y 68370		Active	Orchid 52	Elsa Reclamation & Development Company Ltd. - 100%	1972/07/12	1972/07/19	2043/12/31	\$525	5

Grant	Lease	Status	Claim Name	Owner	Staked	Recorded	Expiry	Renewal Cost per Term (CAD)	Term (Years)
Y 68371		Active	Orchid 53	Elsa Reclamation & Development Company Ltd. - 100%	1972/07/12	1972/07/19	2043/12/31	\$525	5
62955		Active	ORCHID 6	Elsa Reclamation & Development Company Ltd. - 100%	1956/05/16	1956/05/30	2042/12/31	\$525	5
62956		Active	ORCHID 7	Elsa Reclamation & Development Company Ltd. - 100%	1956/05/16	1956/05/30	2042/12/31	\$525	5
62957		Active	ORCHID 8	Elsa Reclamation & Development Company Ltd. - 100%	1956/05/16	1956/05/30	2042/12/31	\$525	5
62958		Active	ORCHID 9	Elsa Reclamation & Development Company Ltd. - 100%	1956/05/16	1956/05/30	2042/12/31	\$525	5
12852	NM00998	Active	ORPHAN	Elsa Reclamation & Development Company Ltd. - 100%	1919/09/15	1919/10/31	2044/01/18	\$210	21
13542	NM00530	Active	OUTCAST FRACTIO	Elsa Reclamation & Development Company Ltd. - 100%	1920/10/01	1920/10/25	2026/11/18	\$210	21
56581	NM01005	Active	OVERTIME 1	Elsa Reclamation & Development Company Ltd. - 100%	1948/08/07	1948/08/13	2044/02/09	\$210	21
56583	NM00439	Active	OVERTIME 13	Elsa Reclamation & Development Company Ltd. - 100%	1948/08/07	1948/08/13	2025/11/26	\$210	21
56584	NM00440	Active	OVERTIME 14	Elsa Reclamation & Development Company Ltd. - 100%	1948/08/07	1948/08/13	2025/11/26	\$210	21
56585	NM00441	Active	OVERTIME 15	Elsa Reclamation & Development Company Ltd. - 100%	1948/08/09	1948/08/13	2025/11/26	\$210	21
56586	NM00442	Active	OVERTIME 16	Elsa Reclamation & Development Company Ltd. - 100%	1948/08/09	1948/08/13	2025/11/26	\$210	21
59453	NM00445	Active	OVERTIME 17	Elsa Reclamation & Development Company Ltd. - 100%	1949/08/17	1949/08/19	2025/11/26	\$210	21
59454	NM00446	Active	OVERTIME 18	Elsa Reclamation & Development Company Ltd. - 100%	1949/08/17	1949/08/19	2025/11/26	\$210	21
59455	NM00447	Active	OVERTIME 19	Elsa Reclamation & Development Company Ltd. - 100%	1949/08/17	1949/08/19	2025/11/26	\$210	21
56582	NM01006	Active	OVERTIME 2	Elsa Reclamation & Development Company Ltd. - 100%	1948/08/07	1948/08/13	2044/02/09	\$210	21
59456	NM00448	Active	OVERTIME 20	Elsa Reclamation & Development Company Ltd. - 100%	1949/08/17	1949/08/19	2025/11/26	\$210	21
59040	NM00285	Active	OXO	Elsa Reclamation & Development Company Ltd. - 100%	1948/09/18	1948/09/21	2024/06/27	\$210	21
14999	NM00700	Active	PACIFIC	Elsa Reclamation & Development Company Ltd. - 100%	1924/06/18	1924/07/14	2036/01/29	\$210	21
59294	NM00997	Active	PACSAX	Elsa Reclamation & Development Company Ltd. - 100%	1949/06/20	1949/06/30	2043/12/29	\$210	21
14093	NM00937	Active	PAGODA	Elsa Reclamation & Development Company Ltd. - 100%	1921/05/04	1921/07/26	2042/08/20	\$210	21
16564	NM00817	Active	PAL OF MINE	Elsa Reclamation & Development Company Ltd. - 100%	1925/05/18	1925/06/30	2039/05/28	\$210	21
14091	NM00362	Active	PASCO	Elsa Reclamation & Development Company Ltd. - 100%	1921/05/04	1921/07/26	2025/04/30	\$210	21
2203	NM00318	Active	PATRICIA	Elsa Reclamation & Development Company Ltd. - 100%	1913/03/25	1913/04/08	2025/02/01	\$210	21
12820	NM00360	Active	PEACH	Elsa Reclamation & Development Company Ltd. - 100%	1919/09/04	1919/10/20	2025/04/30	\$210	21
55206	NM00562	Active	PEARL	Elsa Reclamation & Development Company Ltd. - 100%	1941/08/14	1941/10/30	2027/11/02	\$210	21
12873	NM00813	Active	PERRY FRACTIONA	Elsa Reclamation & Development Company Ltd. - 100%	1919/10/01	1919/11/14	2038/12/28	\$210	21
13158	NM00684	Active	PHOENIX	Elsa Reclamation & Development Company Ltd. - 100%	1920/05/01	1920/06/17	2034/02/27	\$210	21
55500	NM00299	Active	PIL	Elsa Reclamation & Development Company Ltd. - 100%	1946/09/14	1947/02/01	2025/01/30	\$210	21

Grant	Lease	Status	Claim Name	Owner	Staked	Recorded	Expiry	Renewal Cost per Term (CAD)	Term (Years)
12785	NM00688	Active	PINOCHLE	Elsa Reclamation & Development Company Ltd. - 100%	1919/07/30	1919/09/11	2035/10/29	\$210	21
55561	NM00982	Active	PIRATE	Elsa Reclamation & Development Company Ltd. - 100%	1946/10/31	1947/02/17	2043/06/12	\$210	21
55562	NM00983	Active	PIRATE 1	Elsa Reclamation & Development Company Ltd. - 100%	1946/10/31	1947/02/17	2043/06/12	\$210	21
55563	NM00333	Active	PIRATE 2	Elsa Reclamation & Development Company Ltd. - 100%	1946/10/31	1947/02/17	2025/02/08	\$210	21
55564	NM00334	Active	PIRATE 3	Elsa Reclamation & Development Company Ltd. - 100%	1946/10/31	1947/02/17	2025/02/15	\$210	21
55565	NM00335	Active	PIRATE 4	Elsa Reclamation & Development Company Ltd. - 100%	1946/10/31	1947/02/17	2025/02/15	\$210	21
55566	NM00336	Active	PIRATE 5	Elsa Reclamation & Development Company Ltd. - 100%	1946/10/31	1947/02/17	2025/02/15	\$210	21
55567	NM00337	Active	PIRATE 6	Elsa Reclamation & Development Company Ltd. - 100%	1946/10/31	1947/02/17	2025/02/15	\$210	21
55568	NM00338	Active	PIRATE 7	Elsa Reclamation & Development Company Ltd. - 100%	1946/10/31	1947/02/17	2025/02/15	\$210	21
59299	NM00988	Active	PIRATE EAST	Elsa Reclamation & Development Company Ltd. - 100%	1949/06/22	1949/06/30	2043/06/12	\$210	21
16499	NM00349	Active	PLATA	Elsa Reclamation & Development Company Ltd. - 100%	1924/08/07	1924/08/28	2025/03/30	\$210	21
13182	NM00615	Active	POCA PLATA	Elsa Reclamation & Development Company Ltd. - 100%	1920/05/07	1920/06/21	2029/09/30	\$210	21
56559	NM00239	Active	POO FRACTION	Elsa Reclamation & Development Company Ltd. - 100%	1948/06/23	1948/06/25	2028/08/29	\$210	21
12875	NM00686	Active	PORCUPINE	Elsa Reclamation & Development Company Ltd. - 100%	1919/10/03	1919/11/15	2035/01/21	\$210	21
16553	NM00776	Active	PORCUPINE	Elsa Reclamation & Development Company Ltd. - 100%	1925/05/28	1925/06/15	2038/06/20	\$210	21
55389	NM00888	Active	PORKY	Elsa Reclamation & Development Company Ltd. - 100%	1945/08/12	1945/10/26	2041/11/14	\$210	21
55029	NM01002	Active	PREMIER	Elsa Reclamation & Development Company Ltd. - 100%	1937/01/19	1937/02/15	2044/02/02	\$210	21
55308	NM00506	Active	PRINCE	Elsa Reclamation & Development Company Ltd. - 100%	1944/06/18	1945/02/12	2026/11/01	\$210	21
62558	NM00473	Active	PRINCESS FRACTI	Elsa Reclamation & Development Company Ltd. - 100%	1954/10/10	1954/10/27	2025/11/26	\$210	21
59387	NM00569	Active	PUEBLO	Elsa Reclamation & Development Company Ltd. - 100%	1949/07/21	1949/07/29	2027/11/02	\$210	21
16558	NM00855	Active	PUNCH	Elsa Reclamation & Development Company Ltd. - 100%	1925/05/28	1925/06/18	2040/12/29	\$210	21
62269	NM00341	Active	QUEEN	Elsa Reclamation & Development Company Ltd. - 100%	1952/09/13	1952/09/17	2025/02/15	\$210	21
81721	NM00658	Active	R.J.	Elsa Reclamation & Development Company Ltd. - 100%	1962/07/02	1962/07/10	2031/07/10	\$210	21
13073	NM00878	Active	RAM	Elsa Reclamation & Development Company Ltd. - 100%	1920/04/10	1920/06/04	2041/10/17	\$210	21
55436	NM00283	Active	RAND	Elsa Reclamation & Development Company Ltd. - 100%	1946/06/10	1946/06/24	2024/06/27	\$210	21
55022	NM00561	Active	RANDO	Elsa Reclamation & Development Company Ltd. - 100%	1936/10/01	1936/10/28	2027/11/02	\$210	21
14227	NM00938	Active	READY CASH	Elsa Reclamation & Development Company Ltd. - 100%	1921/07/17	1921/09/24	2042/08/20	\$210	21
62309	NM00405	Active	RENO	Elsa Reclamation & Development Company Ltd. - 100%	1952/07/02	1952/07/15	2025/06/12	\$210	21
12800	NM00749	Active	RENO	Elsa Reclamation & Development Company Ltd. - 100%	1919/08/05	1919/10/01	2036/10/19	\$210	21

Grant	Lease	Status	Claim Name	Owner	Staked	Recorded	Expiry	Renewal Cost per Term (CAD)	Term (Years)
84617	NM00792	Active	REVENGE FRACTIO	Elsa Reclamation & Development Company Ltd. - 100%	1965/08/06	1965/08/24	2038/10/17	\$210	21
55387	NM00887	Active	REX	Elsa Reclamation & Development Company Ltd. - 100%	1945/08/10	1945/10/26	2041/11/14	\$210	21
56578	NM00354	Active	REX (F)	Elsa Reclamation & Development Company Ltd. - 100%	1948/07/25	1948/08/03	2025/03/30	\$210	21
12780	NM00619	Active	RICO	Elsa Reclamation & Development Company Ltd. - 100%	1919/07/21	1919/08/27	2030/02/18	\$210	21
14898	NM00677	Active	RIO	Elsa Reclamation & Development Company Ltd. - 100%	1923/10/12	1923/11/15	2035/04/14	\$210	21
55384	NM00507	Active	ROAD	Elsa Reclamation & Development Company Ltd. - 100%	1945/08/06	1945/10/26	2026/11/01	\$210	21
55341	NM00884	Active	ROBIN	Elsa Reclamation & Development Company Ltd. - 100%	1945/06/09	1945/10/17	2041/11/14	\$210	21
62339	NM00291	Active	ROCKET FRACTION	Elsa Reclamation & Development Company Ltd. - 100%	1953/10/01	1953/10/02	2024/07/13	\$210	21
55526	NM00376	Active	ROSE	Elsa Reclamation & Development Company Ltd. - 100%	1946/09/18	1947/02/04	2025/05/22	\$210	21
55271	NM00529	Active	ROSEMARY	Elsa Reclamation & Development Company Ltd. - 100%	1943/07/01	1943/11/09	2026/11/09	\$210	21
12779	NM00616	Active	ROULETTE	Elsa Reclamation & Development Company Ltd. - 100%	1919/07/10	1919/08/27	2030/01/26	\$210	21
13709	NM00558	Active	ROY	Elsa Reclamation & Development Company Ltd. - 100%	1921/04/12	1921/05/28	2027/11/02	\$210	21
61976	NM00575	Active	ROZ FRACTION	Elsa Reclamation & Development Company Ltd. - 100%	1951/09/19	1951/09/19	2027/11/02	\$210	21
62199	NM00402	Active	RUBE	Elsa Reclamation & Development Company Ltd. - 100%	1952/07/21	1952/08/04	2025/06/12	\$210	21
14989	NM00667	Active	RUBY	Elsa Reclamation & Development Company Ltd. - 100%	1924/06/09	1924/07/09	2033/11/24	\$210	21
13038	NM00634	Active	SADIE	Elsa Reclamation & Development Company Ltd. - 100%	1920/03/18	1920/05/06	2029/12/17	\$210	21
55327	NM00803	Active	SAM	Elsa Reclamation & Development Company Ltd. - 100%	1945/04/10	1945/10/16	2038/12/15	\$210	21
55214	NM00839	Active	SANTIAGO	Elsa Reclamation & Development Company Ltd. - 100%	1941/11/06	1942/02/23	2040/07/27	\$210	21
14090	NM00936	Active	SAXON	Elsa Reclamation & Development Company Ltd. - 100%	1921/05/03	1921/07/26	2042/08/20	\$210	21
13591	NM00557	Active	SCOT	Elsa Reclamation & Development Company Ltd. - 100%	1921/01/06	1921/02/18	2027/11/02	\$210	21
12783	NM00621	Active	SCOTTY	Elsa Reclamation & Development Company Ltd. - 100%	1919/07/29	1919/09/10	2030/01/24	\$210	21
56534	NM00437	Active	SEGLE	Elsa Reclamation & Development Company Ltd. - 100%	1948/06/09	1948/06/23	2025/11/26	\$210	21
14288	NM00648	Active	SEXTANT	Elsa Reclamation & Development Company Ltd. - 100%	1921/08/08	1921/10/04	2030/05/15	\$210	21
55309	NM00428	Active	SHAMROCK	Elsa Reclamation & Development Company Ltd. - 100%	1944/06/27	1945/02/12	2025/11/26	\$210	21
12803	NM00704	Active	SHAMROCK	Elsa Reclamation & Development Company Ltd. - 100%	1919/08/04	1919/10/08	2036/04/28	\$210	21
12931	NM00995	Active	SHEPHERD	Elsa Reclamation & Development Company Ltd. - 100%	1919/10/15	1919/12/31	2043/11/19	\$210	21
12990	NM00661	Active	SILVER BELL	Elsa Reclamation & Development Company Ltd. - 100%	1920/02/20	1920/04/15	2031/09/28	\$210	21
38730	NM00801	Active	SILVER FR.	Elsa Reclamation & Development Company Ltd. - 100%	1931/08/20	1931/09/16	2038/12/15	\$210	21
13069	NM00836	Active	SILVER HOARD	Elsa Reclamation & Development Company Ltd. - 100%	1920/03/07	1920/05/31	2040/07/27	\$210	21

Grant	Lease	Status	Claim Name	Owner	Staked	Recorded	Expiry	Renewal Cost per Term (CAD)	Term (Years)
14216	NM00924	Active	SILVER SPOON	Elsa Reclamation & Development Company Ltd. - 100%	1921/07/17	1921/09/24	2042/08/08	\$210	21
55039	NM00631	Active	SIS	Elsa Reclamation & Development Company Ltd. - 100%	1937/08/13	1937/09/03	2029/12/06	\$210	21
59027	NM00921	Active	SISTER	Elsa Reclamation & Development Company Ltd. - 100%	1948/09/11	1948/09/13	2042/07/24	\$210	21
12915	NM00872	Active	SIWASH	Elsa Reclamation & Development Company Ltd. - 100%	1919/09/22	1919/12/19	2041/08/13	\$210	21
38882	NM00629	Active	SLIVER	Elsa Reclamation & Development Company Ltd. - 100%	1936/03/16	1936/03/31	2029/12/06	\$210	21
59436	NM00249	Active	SLOPE 2	Elsa Reclamation & Development Company Ltd. - 100%	1949/08/16	1949/08/19	2028/12/19	\$210	21
62946	NM00476	Active	SNOW	Elsa Reclamation & Development Company Ltd. - 100%	1956/02/08	1956/02/10	2025/11/26	\$210	21
Y 87471		Active	Snowdrift 10	Elsa Reclamation & Development Company Ltd. - 100%	1974/03/18	1974/03/21	2044/12/31	\$525	5
Y 87472		Active	Snowdrift 11	Elsa Reclamation & Development Company Ltd. - 100%	1974/03/18	1974/03/21	2044/12/31	\$525	5
YA01412		Active	Snowdrift 17	Elsa Reclamation & Development Company Ltd. - 100%	1975/09/22	1975/10/08	2044/12/31	\$525	5
Y 87470		Active	Snowdrift 9	Elsa Reclamation & Development Company Ltd. - 100%	1974/03/18	1974/03/21	2043/12/31	\$525	5
12816	NM00620	Active	SOLO 2	Elsa Reclamation & Development Company Ltd. - 100%	1919/08/15	1919/10/18	2030/02/18	\$210	21
59630	NM00459	Active	SOLO FRACTION	Elsa Reclamation & Development Company Ltd. - 100%	1950/07/18	1950/07/21	2025/11/26	\$210	21
14893	NM00698	Active	SPENCER	Elsa Reclamation & Development Company Ltd. - 100%	1923/10/01	1923/11/14	2036/01/27	\$210	21
38813	NM00976	Active	SPOT	Elsa Reclamation & Development Company Ltd. - 100%	1934/10/08	1934/11/12	2043/06/02	\$210	21
55307	NM01003	Active	STANWIX	Elsa Reclamation & Development Company Ltd. - 100%	1944/06/06	1945/02/12	2044/02/02	\$210	21
13721	NM00949	Active	STAURT	Elsa Reclamation & Development Company Ltd. - 100%	1921/04/26	1921/06/07	2042/08/26	\$210	21
13035	NM00503	Active	STONE	Elsa Reclamation & Development Company Ltd. - 100%	1920/03/18	1920/05/06	2026/11/01	\$210	21
83023	NM00595	Active	STONE FRACTION	Elsa Reclamation & Development Company Ltd. - 100%	1963/07/15	1963/07/16	2027/11/02	\$210	21
59457	NM00250	Active	SUDDO 1	Elsa Reclamation & Development Company Ltd. - 100%	1949/08/16	1949/08/19	2028/12/19	\$210	21
59466	NM00259	Active	SUDDO 10	Elsa Reclamation & Development Company Ltd. - 100%	1949/08/16	1949/08/19	2028/12/19	\$210	21
59467	NM00260	Active	SUDDO 11	Elsa Reclamation & Development Company Ltd. - 100%	1949/08/16	1949/08/19	2028/12/19	\$210	21
59458	NM00251	Active	SUDDO 2	Elsa Reclamation & Development Company Ltd. - 100%	1949/08/16	1949/08/18	2028/12/19	\$210	21
59459	NM00252	Active	SUDDO 3	Elsa Reclamation & Development Company Ltd. - 100%	1949/08/16	1949/08/19	2028/12/19	\$210	21
59460	NM00253	Active	SUDDO 4	Elsa Reclamation & Development Company Ltd. - 100%	1949/08/16	1949/08/19	2028/12/19	\$210	21
59461	NM00254	Active	SUDDO 5	Elsa Reclamation & Development Company Ltd. - 100%	1949/08/16	1949/08/19	2028/12/19	\$210	21
59462	NM00255	Active	SUDDO 6	Elsa Reclamation & Development Company Ltd. - 100%	1949/08/16	1949/08/19	2028/12/19	\$210	21
59463	NM00256	Active	SUDDO 7	Elsa Reclamation & Development Company Ltd. - 100%	1949/08/16	1949/08/19	2028/12/19	\$210	21
59464	NM00257	Active	SUDDO 8	Elsa Reclamation & Development Company Ltd. - 100%	1949/08/16	1949/08/19	2028/12/19	\$210	21

Grant	Lease	Status	Claim Name	Owner	Staked	Recorded	Expiry	Renewal Cost per Term (CAD)	Term (Years)
59465	NM00258	Active	SUDDO 9	Elsa Reclamation & Development Company Ltd. - 100%	1949/08/16	1949/08/19	2028/12/19	\$210	21
84580	NM00789	Active	SURPLOMB 2	Elsa Reclamation & Development Company Ltd. - 100%	1965/07/07	1965/07/14	2038/10/17	\$210	21
84581	NM00790	Active	SURPLOMB 3	Elsa Reclamation & Development Company Ltd. - 100%	1965/07/10	1965/07/14	2038/10/17	\$210	21
81225	NM00652	Active	SUSY Q.	Elsa Reclamation & Development Company Ltd. - 100%	1962/06/15	1962/06/26	2031/03/12	\$210	21
15303	NM00828	Active	SWISS	Elsa Reclamation & Development Company Ltd. - 100%	1928/09/29	1928/10/26	2039/08/18	\$210	21
59293	NM00931	Active	SYLDIX	Elsa Reclamation & Development Company Ltd. - 100%	1949/06/17	1949/06/30	2042/08/08	\$210	21
14307	NM00241	Active	SYLVIA	Elsa Reclamation & Development Company Ltd. - 100%	1921/07/20	1921/10/06	2029/02/28	\$210	21
55334	NM00240	Active	TAKU	Elsa Reclamation & Development Company Ltd. - 100%	1945/05/23	1945/10/16	2028/09/07	\$210	21
59327	NM00407	Active	TALISMAN	Elsa Reclamation & Development Company Ltd. - 100%	1949/07/13	1949/07/19	2025/06/19	\$210	21
83132	NM00623	Active	TECH	Elsa Reclamation & Development Company Ltd. - 100%	1963/08/06	1963/08/13	2030/02/28	\$210	21
84628	NM00794	Active	TESS	Elsa Reclamation & Development Company Ltd. - 100%	1965/08/27	1965/09/09	2038/10/17	\$210	21
16313	NM01001	Active	THELMA	Elsa Reclamation & Development Company Ltd. - 100%	1927/03/14	1927/04/07	2044/02/02	\$210	21
16204	NM00626	Active	THISTLE	Elsa Reclamation & Development Company Ltd. - 100%	1926/07/16	1926/08/12	2029/12/03	\$210	21
15207	NM00281	Active	TICK	Elsa Reclamation & Development Company Ltd. - 100%	1928/03/31	1928/04/28	2024/06/27	\$210	21
12807	NM00751	Active	TIGER	Elsa Reclamation & Development Company Ltd. - 100%	1919/08/27	1919/10/10	2036/10/27	\$210	21
14885	NM00913	Active	TILLY	Elsa Reclamation & Development Company Ltd. - 100%	1923/09/02	1923/10/22	2042/07/24	\$210	21
13027	NM00835	Active	TIN CAN	Elsa Reclamation & Development Company Ltd. - 100%	1920/03/07	1920/05/05	2040/07/27	\$210	21
59335	NM00864	Active	TIP TOP	Elsa Reclamation & Development Company Ltd. - 100%	1949/07/15	1949/07/19	2041/05/15	\$210	21
16253	NM00678	Active	TIPPY	Elsa Reclamation & Development Company Ltd. - 100%	1926/09/20	1926/10/06	2035/04/14	\$210	21
59295	NM00962	Active	TIPTOE	Elsa Reclamation & Development Company Ltd. - 100%	1949/06/20	1949/06/30	2042/08/29	\$210	21
55065	NM00838	Active	TIPTOP	Elsa Reclamation & Development Company Ltd. - 100%	1938/03/04	1938/03/28	2040/07/27	\$210	21
56505	NM00947	Active	TOM BOY	Elsa Reclamation & Development Company Ltd. - 100%	1947/10/06	1947/10/10	2042/08/22	\$210	21
38741	NM00680	Active	TOMTOM	Elsa Reclamation & Development Company Ltd. - 100%	1932/05/30	1932/06/20	2035/04/14	\$210	21
16079	NM00683	Active	TOO GOOD	Elsa Reclamation & Development Company Ltd. - 100%	1925/09/12	1925/11/29	2035/06/14	\$210	21
56504	NM00946	Active	TOPOLO	Elsa Reclamation & Development Company Ltd. - 100%	1947/09/15	1947/09/26	2042/08/22	\$210	21
13622	NM00644	Active	TRAVICE	Elsa Reclamation & Development Company Ltd. - 100%	1921/03/12	1921/04/23	2030/04/22	\$210	21
59161	NM00842	Active	TREASURE ISLAND	Elsa Reclamation & Development Company Ltd. - 100%	1948/11/18	1948/11/22	2040/07/27	\$210	21
62281	NM00345	Active	TREY	Elsa Reclamation & Development Company Ltd. - 100%	1952/09/27	1952/10/02	2025/02/15	\$210	21
14332	NM00604	Active	TRIANGLE	Elsa Reclamation & Development Company Ltd. - 100%	1921/08/24	1921/10/18	2029/07/11	\$210	21

Grant	Lease	Status	Claim Name	Owner	Staked	Recorded	Expiry	Renewal Cost per Term (CAD)	Term (Years)
12838	NM00879	Active	TUNDRA	Elsa Reclamation & Development Company Ltd. - 100%	1919/09/06	1919/10/27	2041/11/01	\$210	21
14833	NM00662	Active	TUNNEL	Elsa Reclamation & Development Company Ltd. - 100%	1923/06/04	1923/07/19	2031/09/30	\$210	21
55525	NM00375	Active	U. N.	Elsa Reclamation & Development Company Ltd. - 100%	1946/09/18	1947/02/04	2025/05/22	\$210	21
83533	NM00657	Active	U.K. No. 17	Elsa Reclamation & Development Company Ltd. - 100%	1964/07/14	1964/07/17	2031/03/12	\$210	21
62723	NM00606	Active	UK 1	Elsa Reclamation & Development Company Ltd. - 100%	1955/03/22	1955/03/29	2029/04/30	\$210	21
62735	NM00610	Active	UK 13	Elsa Reclamation & Development Company Ltd. - 100%	1955/03/22	1955/03/29	2029/04/30	\$210	21
62736	NM00611	Active	UK 14	Elsa Reclamation & Development Company Ltd. - 100%	1955/03/22	1955/03/29	2029/04/30	\$210	21
62835	NM00612	Active	UK 15	Elsa Reclamation & Development Company Ltd. - 100%	1955/07/06	1955/07/08	2029/04/30	\$210	21
62836	NM00613	Active	UK 16	Elsa Reclamation & Development Company Ltd. - 100%	1955/07/06	1955/07/08	2029/04/30	\$210	21
62724	NM00607	Active	UK 2	Elsa Reclamation & Development Company Ltd. - 100%	1955/03/22	1955/03/29	2029/04/30	\$210	21
62729	NM00608	Active	UK 7	Elsa Reclamation & Development Company Ltd. - 100%	1955/03/22	1955/03/29	2029/04/30	\$210	21
62730	NM00609	Active	UK 8	Elsa Reclamation & Development Company Ltd. - 100%	1955/03/22	1955/03/29	2029/04/30	\$210	21
12923	NM00675	Active	UNCLE SAM	Elsa Reclamation & Development Company Ltd. - 100%	1919/10/12	1919/12/26	2035/03/12	\$210	21
14002	NM00856	Active	UPTON	Elsa Reclamation & Development Company Ltd. - 100%	1921/05/07	1921/06/25	2041/02/05	\$210	21
55270	NM00505	Active	V.D.	Elsa Reclamation & Development Company Ltd. - 100%	1943/06/29	1943/11/09	2026/11/01	\$210	21
56503	NM00352	Active	V.O.	Elsa Reclamation & Development Company Ltd. - 100%	1947/09/17	1947/09/24	2025/03/30	\$210	21
59338	NM00974	Active	VALLEY	Elsa Reclamation & Development Company Ltd. - 100%	1949/07/15	1949/07/19	2043/05/07	\$210	21
16271	NM01013	Active	VAN KEUREN	Elsa Reclamation & Development Company Ltd. - 100%	1926/09/01	1926/10/23	2044/03/22	\$210	21
16375	NM00282	Active	VENTURE	Elsa Reclamation & Development Company Ltd. - 100%	1927/09/04	1927/10/18	2024/06/27	\$210	21
Y 33308		Active	Venus 3	Elsa Reclamation & Development Company Ltd. - 100%	1970/04/05	1970/04/06	2028/12/31	\$525	5
Y 97333		Active	Venus 4	Elsa Reclamation & Development Company Ltd. - 100%	1975/05/08	1975/05/09	2028/12/31	\$525	5
80227	NM00527	Active	VENUS FRACTION 1	Elsa Reclamation & Development Company Ltd. - 100%	1957/06/20	1957/07/03	2026/11/07	\$210	21
80228	NM00528	Active	VENUS FRACTION 2	Elsa Reclamation & Development Company Ltd. - 100%	1957/06/20	1957/07/03	2026/11/07	\$210	21
13156	NM00826	Active	VERNA	Elsa Reclamation & Development Company Ltd. - 100%	1920/05/05	1920/06/17	2039/08/18	\$210	21
15346	NM00426	Active	VIMY	Elsa Reclamation & Development Company Ltd. - 100%	1929/05/31	1929/06/21	2025/11/26	\$210	21
38723	NM00560	Active	VIOLA	Elsa Reclamation & Development Company Ltd. - 100%	1931/07/27	1931/08/14	2027/11/02	\$210	21
13153	NM00676	Active	VIOLA	Elsa Reclamation & Development Company Ltd. - 100%	1920/05/18	1920/06/16	2035/03/14	\$210	21
14092	NM00922	Active	WALL EYE	Elsa Reclamation & Development Company Ltd. - 100%	1921/05/04	1921/07/26	2042/08/08	\$210	21
12998	NM00860	Active	WALSH	Elsa Reclamation & Development Company Ltd. - 100%	1920/02/28	1920/04/17	2041/02/28	\$210	21

Grant	Lease	Status	Claim Name	Owner	Staked	Recorded	Expiry	Renewal Cost per Term (CAD)	Term (Years)
55361	NM00977	Active	WANDERER	Elsa Reclamation & Development Company Ltd. - 100%	1945/07/04	1945/10/25	2043/06/02	\$210	21
55496	NM00964	Active	WARREN	Elsa Reclamation & Development Company Ltd. - 100%	1946/09/15	1947/02/01	2043/02/03	\$210	21
13367	NM00703	Active	WARRIOR	Elsa Reclamation & Development Company Ltd. - 100%	1920/08/12	1920/10/12	2036/02/27	\$210	21
15365	NM00770	Active	WASP	Elsa Reclamation & Development Company Ltd. - 100%	1929/06/11	1929/07/11	2038/03/27	\$210	21
13109	NM00130	Active	WATCH	Elsa Reclamation & Development Company Ltd. - 100%	1920/04/27	1920/06/10	2026/07/18	\$210	21
62945	NM00475	Active	WEATHER FRACTIO	Elsa Reclamation & Development Company Ltd. - 100%	1955/12/30	1956/01/06	2025/11/26	\$210	21
YB65005		Active	Webfoot	Elsa Reclamation & Development Company Ltd. - 100%	1995/09/28	1995/09/29	2027/12/31	\$525	5
16557	NM00754	Active	WESTON	Elsa Reclamation & Development Company Ltd. - 100%	1925/05/30	1925/06/18	2037/03/07	\$210	21
14231	NM00939	Active	WETT	Elsa Reclamation & Development Company Ltd. - 100%	1921/07/18	1921/09/24	2042/08/20	\$210	21
14081	NM00797	Active	WHIPSAW	Elsa Reclamation & Development Company Ltd. - 100%	1921/06/11	1921/07/23	2038/12/15	\$210	21
13110	NM00823	Active	WHITEHORSE	Elsa Reclamation & Development Company Ltd. - 100%	1920/04/27	1920/06/10	2039/08/05	\$210	21
14095	NM00923	Active	WIGWAM	Elsa Reclamation & Development Company Ltd. - 100%	1921/05/04	1921/07/26	2042/08/08	\$210	21
56500	NM01004	Active	WILD CAT	Elsa Reclamation & Development Company Ltd. - 100%	1947/09/18	1947/09/22	2044/02/02	\$210	21
56417	NM00378	Active	WILD MAN	Elsa Reclamation & Development Company Ltd. - 100%	1947/06/05	1947/06/10	2025/05/22	\$210	21
14404	NM00605	Active	WILLIAM FOURTH	Elsa Reclamation & Development Company Ltd. - 100%	1921/09/20	1921/11/05	2029/07/11	\$210	21
16083	NM00929	Active	WINFRED	Elsa Reclamation & Development Company Ltd. - 100%	1925/09/11	1925/11/20	2042/08/08	\$210	21
16498	NM00943	Active	WINSOME	Elsa Reclamation & Development Company Ltd. - 100%	1924/08/04	1924/08/28	2042/08/20	\$210	21
12871	NM00689	Active	WOLVERINE	Elsa Reclamation & Development Company Ltd. - 100%	1919/10/03	1919/11/13	2035/10/30	\$210	21
80518	NM00585	Active	WREN FRACTION	Elsa Reclamation & Development Company Ltd. - 100%	1960/07/19	1960/08/04	2027/11/02	\$210	21
15331	NM00244	Active	X	Elsa Reclamation & Development Company Ltd. - 100%	1929/05/09	1929/05/30	2029/02/28	\$210	21
55392		Active	YUKON	Elsa Reclamation & Development Company Ltd. - 100%	1945/11/03	1946/01/30	2027/12/31	\$525	5
56515	NM00948	Active	YUKON	Elsa Reclamation & Development Company Ltd. - 100%	1948/04/15	1948/04/19	2042/08/22	\$210	21
62312	NM00391	Active	ZELMA 1	Elsa Reclamation & Development Company Ltd. - 100%	1953/07/19	1953/07/31	2025/05/22	\$210	21
62313	NM00392	Active	ZELMA 2	Elsa Reclamation & Development Company Ltd. - 100%	1953/07/19	1953/07/31	2025/05/22	\$210	21
62314	NM00356	Active	ZELMA 3	Elsa Reclamation & Development Company Ltd. - 100%	1953/07/19	1953/07/31	2025/03/30	\$210	21
62315	NM00357	Active	ZELMA 4	Elsa Reclamation & Development Company Ltd. - 100%	1953/07/19	1953/07/31	2025/03/30	\$210	21
YB29728		Active	ALLA 5	Elsa Reclamation & Development Company Ltd. - 49%, Banyan Gold Corporation - 51%	1993/03/16	1993/03/19	2044/12/31	\$525	5
YB29729		Active	ALLA 6	Elsa Reclamation & Development Company Ltd. - 49%, Banyan Gold Corporation - 51%	1993/03/16	1993/03/19	2044/12/31	\$525	5

Grant	Lease	Status	Claim Name	Owner	Staked	Recorded	Expiry	Renewal Cost per Term (CAD)	Term (Years)
62152	NM00319	Active	BUCK	Elsa Reclamation & Development Company Ltd. - 49%, Banyan Gold Corporation - 51%	1952/06/14	1952/07/02	2025/02/01	\$210	21
55504	NM00302	Active	BUCONJO 1	Elsa Reclamation & Development Company Ltd. - 49%, Banyan Gold Corporation - 51%	1946/09/14	1947/02/01	2025/01/31	\$210	21
55516	NM00314	Active	BUCONJO 13	Elsa Reclamation & Development Company Ltd. - 49%, Banyan Gold Corporation - 51%	1946/09/19	1947/02/03	2025/01/31	\$210	21
55517	NM00315	Active	BUCONJO 14	Elsa Reclamation & Development Company Ltd. - 49%, Banyan Gold Corporation - 51%	1946/09/24	1947/02/03	2025/01/31	\$210	21
55518	NM00316	Active	BUCONJO 15	Elsa Reclamation & Development Company Ltd. - 49%, Banyan Gold Corporation - 51%	1946/09/19	1947/02/03	2025/01/31	\$210	21
62154	NM00317	Active	BUCONJO 16	Elsa Reclamation & Development Company Ltd. - 49%, Banyan Gold Corporation - 51%	1952/06/16	1952/07/02	2025/01/31	\$210	21
55505	NM00303	Active	BUCONJO 2	Elsa Reclamation & Development Company Ltd. - 49%, Banyan Gold Corporation - 51%	1946/09/14	1947/02/01	2025/01/31	\$210	21
55506	NM00304	Active	BUCONJO 3	Elsa Reclamation & Development Company Ltd. - 49%, Banyan Gold Corporation - 51%	1946/09/14	1947/02/01	2025/01/31	\$210	21
55507	NM00305	Active	BUCONJO 4	Elsa Reclamation & Development Company Ltd. - 49%, Banyan Gold Corporation - 51%	1946/09/14	1947/02/01	2025/01/31	\$210	21
55508	NM00306	Active	BUCONJO 5	Elsa Reclamation & Development Company Ltd. - 49%, Banyan Gold Corporation - 51%	1946/09/14	1947/02/01	2025/01/31	\$210	21
55510	NM00308	Active	BUCONJO 7	Elsa Reclamation & Development Company Ltd. - 49%, Banyan Gold Corporation - 51%	1904/09/14	1947/02/01	2025/01/31	\$210	21
55503	NM00301	Active	BUCONJO FRACTIO	Elsa Reclamation & Development Company Ltd. - 49%, Banyan Gold Corporation - 51%	1946/09/14	1947/02/01	2025/01/31	\$210	21
YB43729		Active	Raven	Elsa Reclamation & Development Company Ltd. - 49%, Banyan Gold Corporation - 51%	1994/10/18	1994/10/18	2027/12/31	\$525	5
Y 88686		Active	Snowdrift	Elsa Reclamation & Development Company Ltd. - 49%, Banyan Gold Corporation - 51%	1974/05/31	1974/06/05	2044/12/31	\$525	5
Y 87462		Active	Snowdrift 1	Elsa Reclamation & Development Company Ltd. - 49%, Banyan Gold Corporation - 51%	1974/03/15	1974/03/21	2044/12/31	\$525	5
Y 97219		Active	Snowdrift 12	Elsa Reclamation & Development Company Ltd. - 49%, Banyan Gold Corporation - 51%	1974/12/18	1974/12/23	2044/12/31	\$525	5
Y 97220		Active	Snowdrift 13	Elsa Reclamation & Development Company Ltd. - 49%, Banyan Gold Corporation - 51%	1974/12/18	1974/12/23	2043/12/31	\$525	5
Y 97221		Active	Snowdrift 14	Elsa Reclamation & Development Company Ltd. - 49%, Banyan Gold Corporation - 51%	1974/12/18	1974/12/23	2043/12/31	\$525	5
Y 97222		Active	Snowdrift 15	Elsa Reclamation & Development Company Ltd. - 49%, Banyan Gold Corporation - 51%	1974/12/18	1974/12/23	2043/12/31	\$525	5
Y 97223		Active	Snowdrift 16	Elsa Reclamation & Development Company Ltd. - 49%, Banyan Gold Corporation - 51%	1974/12/18	1974/12/23	2043/12/31	\$525	5
YA01413		Active	Snowdrift 18	Elsa Reclamation & Development Company Ltd. - 49%, Banyan Gold Corporation - 51%	1975/09/22	1975/10/08	2043/12/31	\$525	5

Grant	Lease	Status	Claim Name	Owner	Staked	Recorded	Expiry	Renewal Cost per Term (CAD)	Term (Years)
YA01414		Active	Snowdrift 19	Elsa Reclamation & Development Company Ltd. - 49%, Banyan Gold Corporation - 51%	1975/09/22	1975/10/08	2043/12/31	\$525	5
Y 87463		Active	Snowdrift 2	Elsa Reclamation & Development Company Ltd. - 49%, Banyan Gold Corporation - 51%	1974/03/15	1974/03/21	2043/12/31	\$525	5
YA01415		Active	Snowdrift 20	Elsa Reclamation & Development Company Ltd. - 49%, Banyan Gold Corporation - 51%	1975/09/22	1975/10/08	2042/12/31	\$525	5
YA01416		Active	Snowdrift 21	Elsa Reclamation & Development Company Ltd. - 49%, Banyan Gold Corporation - 51%	1975/09/22	1975/10/08	2043/12/31	\$525	5
Y 87464		Active	Snowdrift 3	Elsa Reclamation & Development Company Ltd. - 49%, Banyan Gold Corporation - 51%	1974/03/15	1974/03/21	2043/12/31	\$525	5
Y 87465		Active	Snowdrift 4	Elsa Reclamation & Development Company Ltd. - 49%, Banyan Gold Corporation - 51%	1974/03/18	1974/03/21	2042/12/31	\$525	5
Y 87466		Active	Snowdrift 5	Elsa Reclamation & Development Company Ltd. - 49%, Banyan Gold Corporation - 51%	1974/03/18	1974/03/21	2042/12/31	\$525	5
Y 87467		Active	Snowdrift 6	Elsa Reclamation & Development Company Ltd. - 49%, Banyan Gold Corporation - 51%	1974/03/18	1974/03/21	2042/12/31	\$525	5
Y 87468		Active	Snowdrift 7	Elsa Reclamation & Development Company Ltd. - 49%, Banyan Gold Corporation - 51%	1974/03/18	1974/03/21	2042/12/31	\$525	5
Y 87469		Active	Snowdrift 8	Elsa Reclamation & Development Company Ltd. - 49%, Banyan Gold Corporation - 51%	1974/03/18	1974/03/21	2042/12/31	\$525	5
13452	NM00643	Active	RICO	Evelyn Crandall Exec Est. Bessie E. Stewart - 50%, Elsa Reclamation & Development Company Ltd. - 50%	1920/08/02	1920/10/02	2030/03/28	\$210	21
13060	NM00832	Active	KIDDO	John Hawthorne - 50%, Elsa Reclamation & Development Company Ltd. - 50%	1920/04/03	1920/05/11	2040/11/11	\$210	21
16393	NM00993	Active	ARGENTUM	Nora Ethel Swenson - 50%, Elsa Reclamation & Development Company Ltd. - 50%	1928/02/02	1928/02/25	2043/11/16	\$210	21